



XLS-810160 & XLS-810240 Tape Libraries

Installation Manual

Document No. 501801 Rev. 07-01-19

Copyright© 2010 by Qualstar Corporation — All Rights Reserved

Information contained in this document is copyrighted by Qualstar Corporation. It is intended for use by Qualstar's customers and prospective customers to evaluate, integrate, operate, and maintain Qualstar products. Customers and prospective customers may reproduce this document as needed for these uses. Reproduction in whole or in part for any other use or by any other party is prohibited without prior written permission from Qualstar Corporation.

Disclaimer

Every effort has been made to keep the information contained in this document current and accurate as of the date of publication or revision. However, no guarantee is given or implied that the document is error-free or that it is accurate with regard to any specification.

Qualstar reserves the right to modify the design or specification without notice. This specification may not be construed as a contractual obligation except as specifically agreed to by Qualstar in writing at the time of order.

Trademark Notices

Qualstar and the Qualstar logo are registered trademarks and X-Link is a trademark of Qualstar Corporation. Other trademarks are the property of their respective owners.

Revision History

Revision	Release Date	Description
A	02-Mar-2010	Initial release
07-01-19	01-Jul-2019	Address updated

Notices

Qualstar products are covered by one or more of the following patents: 6,271,982; 6,560,061; and 7,181,313. Other patents pending.

Qualstar equipment is manufactured from new parts, or new and used parts. In some cases, Qualstar equipment may not be new and may have been previously installed. Regardless, Qualstar's warranty terms apply unless the equipment is specifically identified by Qualstar as "used" or "refurbished."

This equipment has been tested and found to comply with the limits for a Class A digital device, pursuant to Part 15 of the FCC Rules. These limits are designed to provide reasonable protection against harmful interference when the equipment is operated in a commercial environment. This equipment generates, uses, and can radiate radio frequency energy and, if not installed and used in accordance with the instruction manual, may cause harmful interference to radio communications. Operation of this equipment in a residential area is likely to cause harmful interference in which case the user will be required to correct the interference at his own expense. Shielded cables are required for this device to comply with FCC Rules. Use shielded cables when connecting this device to others.

European Union Directive 89/336/EEC and Standard EN55022 (Electromagnetic Compatibility)

This product has been tested and is certified to be compliant with the Class A provisions of the U.S., Canadian, and European standards for electromagnetic compatibility (EMC).

European Directive on Waste Electrical and Electronic Equipment (WEEE)



Qualstar encourages its customers to use current recycling practices in order to reduce the burden that waste electronic products place on the environment.

If you are retiring a fully functional tape library, you are encouraged to transfer the functional unit to a new user, thereby extending the useful life of the tape library. The manufacture of all products requires the consumption of energy. By extending the life of the tape library, energy is conserved.

In accordance with environmental directives that are being implemented in many countries (refer to the European Directive on Waste Electrical and Electronic Equipment - WEEE), Qualstar provides customers with ["End of Life Instructions"](#) that identify the process for recycling the materials and components that make up a Qualstar tape library.

End of Life Instructions

Tools required

- #1 and #2 Phillips screwdrivers
- T20 Torx head screwdriver
- Hex head (Allen) wrench/driver set
- 1/4-inch hex nut driver

Disassembly procedure

1. Remove the door(s).
2. Remove the front panel.
3. Remove the external side panels.
4. Remove the internal subassemblies.

Items recyclable using conventional methods

- **Aluminum:** Front panel, exterior side and rear panels, robotics, cartridge and drive bays, carousel and shroud panels
- **Stainless steel:** Robot guides
- **Steel:** Frames, fasteners
- **Plastic:** Windows, cartridge magazines, tape cassettes
- **Copper:** Internal wiring, motors, SCSI cables
- **Paper:** Manuals

Items requiring special disposal due to lead-based solder

- **Printed circuit boards:** Controller card, miscellaneous small printed circuit boards

Items that may have salvage or resale value

- Tape drives
- EMI line power filter

Reduction of Hazardous Substances (RoHS)

Qualstar is committed to the implementation of RoHS (Restriction of the use of certain hazardous substances in electrical and electronic equipment) in accordance with the European Directive. The compliance date is July 1, 2006, at which time Qualstar will certify that its tape library products are compliant with the RoHS standard.

Qualstar tape libraries are classified as “Information Technology Storage Array Systems” for which the RoHS Directive provides an exemption for lead solder until the year 2010. Until Qualstar replaces lead-based solder with lead-free solder, affected subassemblies must be disposed of appropriately.

Technical Support

The best source for service-related information is your system reseller. Alternately, you can reach the Qualstar Technical Support Department at:

Qualstar Corporation
1267 Flynn Road
Camarillo, CA 93012

Monday - Friday 7:00 AM to 4:00 PM PST

Phone: (805) 416-7055
Toll Free: (877) 886-2758

After hours

Phone: (805) 583-7744
option 4

E-mail: support@qualstar.com
E-mail: sales@qualstar.com

www.qualstar.com

Table of Contents

1	About This Manual	1-1
1.1	About the XLS	1-1
1.2	Library Resource Module (LRM).	1-4
1.3	Media Expansion Module (MEM).	1-16
1.4	How This Manual Is Organized	1-17
1.5	Conventions Used in This Manual	1-18
1.6	For More Information	1-20
2	Preparing for Installation	2-1
2.1	Installation Overview	2-2
2.2	Installation Check List	2-4
3	Unpacking the XLS	3-1
3.1	Inspecting the Shipment	3-1
3.2	Unpacking the XLS	3-3
4	Installing the LRM.	4-1
4.1	Extending the Leveling Feet	4-1
5	Installing a MEM.	5-1
5.1	Preparing the LRM.	5-1
5.2	Removing the X-Axis Hard Stop	5-3
5.3	Releasing the Carousel Locks in a XLS-85000 MEM	5-4
5.4	Connecting the Carousel Controller Cable	5-6
5.5	Attaching the LRM to the MEM	5-8
5.6	Lowering the Leveling Feet	5-9
5.7	Installing the Side Panel on the MEM.	5-11

6	Installing an Expansion Pod	6-1
6.1	Removing the Left Side Panel from the XLS-810160/810240	6-2
6.2	Installing the Expansion Pod Mounting Hardware.	6-3
6.3	Removing the X-Axis Hard Stop.	6-7
6.4	Attaching the Expansion Pod to the XLS-810160/810240.	6-8
6.5	Installing the Rear Side Panel.	6-11
7	Installing the Tape Drive Assemblies	7-1
7.1	Before You Begin.	7-2
7.2	Installing Tape Drive and Drive Filler Assemblies	7-12
8	Connecting the XLS	8-1
8.1	Before You Begin.	8-1
8.2	Connecting the Cables.	8-1
9	Applying Power and Logging Into X-Link	9-1
9.1	Preparing to Power on the Library	9-1
9.2	Connecting the Library to Power	9-3
9.3	Logging Into X-Link	9-11
10	Configuring the Physical Library	10-1
10.1	Connecting the XLS to a Computer	10-1
10.2	Aligning the Gripper with a MEM.	10-4
10.3	Calibrating an Expansion Pod Equipped Library	10-9
10.4	Verifying the Hardware Configuration	10-19
10.5	Entering Configuration Information	10-22
10.6	Defining Other Library Settings and Policies.	10-33
11	Setting Up Logical Libraries	11-1
11.1	About Physical and Logical Libraries.	11-1
11.2	Creating a New Logical Library	11-3
11.3	Viewing the Inventory Report.	11-11
12	Loading Cartridges	12-1
12.1	Installing Cartridges in the Reserved Slots.	12-1

12.2	Precautions for Handling Cartridges	12-3
12.3	Preparing Cartridges	12-4
12.4	Installing Cartridges in Cartridge Slots.	12-5
13	Scanning the Fiducials and Inventory.	13-1
13.1	Before You Begin.	13-1
13.2	Scanning and Calibrating the Fiducials.	13-2
13.3	Scanning the Inventory and Locking the Doors.	13-7
14	Testing the Installation	14-1
14.1	Putting the XLS in Logical Mode.	14-1
14.2	Bringing a Logical Library Online	14-2
14.3	Starting the Application	14-3
14.4	Troubleshooting Installation Problems	14-4
14.5	Downloading the Library Configuration	14-5
Appendix A	Library Addresses	A-1
A.1	Addresses for the XLS-810160/810240	A-2
A.2	Addresses for Expansion Pod, I/O Ports, and Fixed Port Slots	A-5
A.3	Addresses for the Media Expansion Module (MEM)	A-7
Glossary	GL-1
Index.	IN-1

This manual is intended for anyone installing the Qualstar® XLS Library. It provides instructions for completing XLS installation and configuration.

Important: Although Qualstar has made every effort to ensure the accuracy of the information contained in this manual, no guarantee is expressed or implied that the manual is error free. Qualstar reserves the right to make changes at any time without prior notification.

1.1 About the XLS

The Qualstar XLS Enterprise Tape Library contains large-capacity tape drives, a variable number of cartridge storage slots, a high-speed robotic mechanism for moving cartridges between the tape drives and the storage slots, and I/O ports for importing and exporting cartridges from the library. Six XLS models are currently available—the XLS-8161100, XLS-832700, the XLS-820500, XLS-812300, and the XLS-810160/810240. This manual will focus on the XLS-810160 and XLS-810240 models.

Shown in [Figure 1-1 on page 1-2](#), the library uses two building blocks:

- The *Library Resource Module (LRM)*, described in [Section 1.2 on page 1-4](#), is the fully featured base cabinet containing the power system; the robotic handler; the control electronics; and the tape drives, I/O ports, and cartridge slots.
- The optional Media Expansion Modules (MEM), described in [Section 1.3 on page 1-16](#), is a rotary tape carousel that attaches to the left side of an LRM.

- The XLS-85000 (also referred to as a MEM2) contains 517 cartridges.



Figure 1-1 LRM with one MEM2

1.1.1 XLS-810160/810240

Shown in [Figure 1-2](#), the XLS-810160/810240 accommodates up to 10 tape drives, up to 245 cartridges, and up to two, 10-slot I/O ports. As an option, one Media Expansion Modules (MEM) can be installed on the left side of the XLS-810160/810240. See [Section 1.3 on page 1-16](#) for more information.

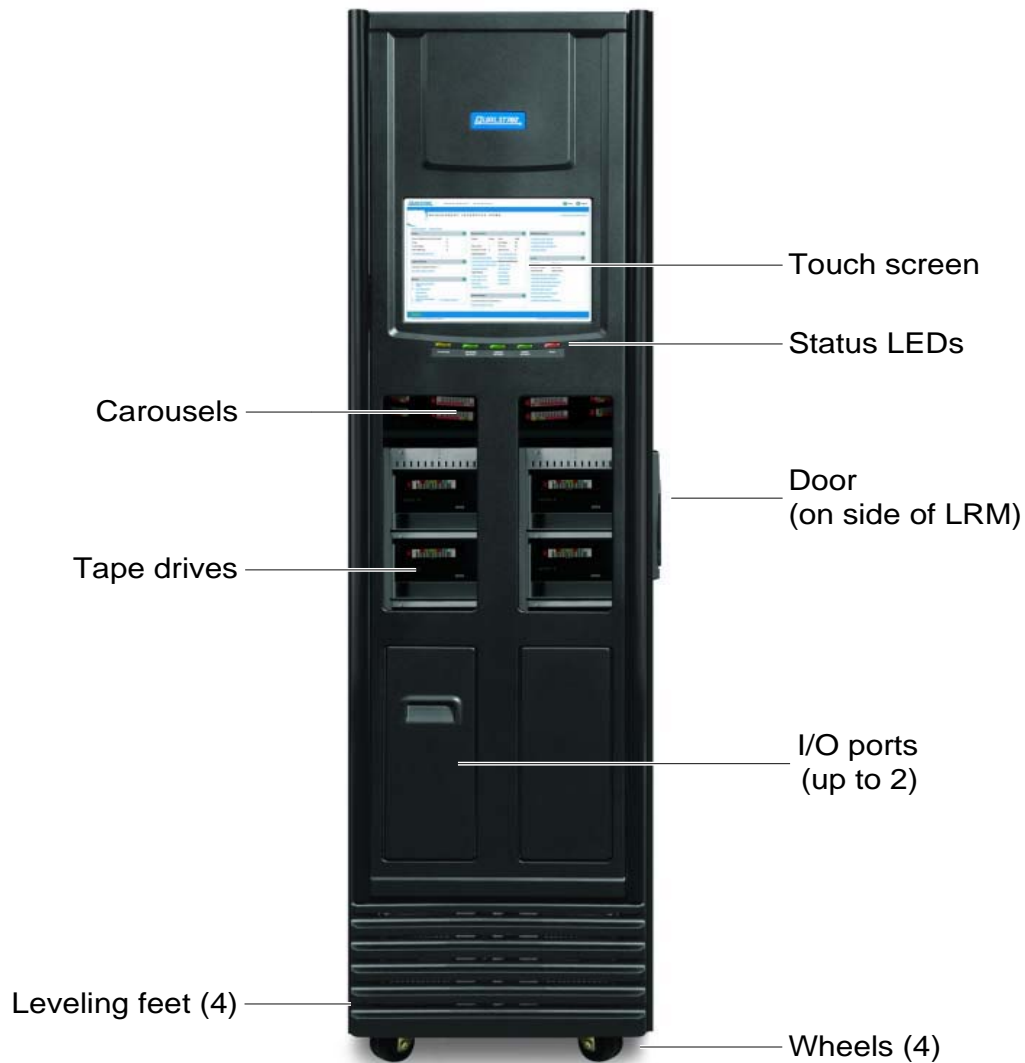

Figure 1-2 Front view of the XLS-810160/810240

1.2 Library Resource Module (LRM)

[Figure 1-3](#) shows the inside of the LRM, while [Figure 1-4 on page 1-5](#) shows the back of the LRM. The LRM contains the following components and features:

- PC bay, which includes the system controller (see [Section 1.2.1 on page 1-5](#))
- Touch screen and LEDs (see [Section 1.2.2 on page 1-8](#))
- Robotic handler and barcode reader (see [Section 1.2.3 on page 1-9](#))
- Tape drives (see [Section 1.2.4 on page 1-12](#))
- I/O ports (see [Section 1.2.5 on page 1-14](#))
- Cartridge slots (see [Section 1.2.6 on page 1-15](#))
- Doors and light curtain sensors (see [Section 1.2.7 on page 1-15](#))

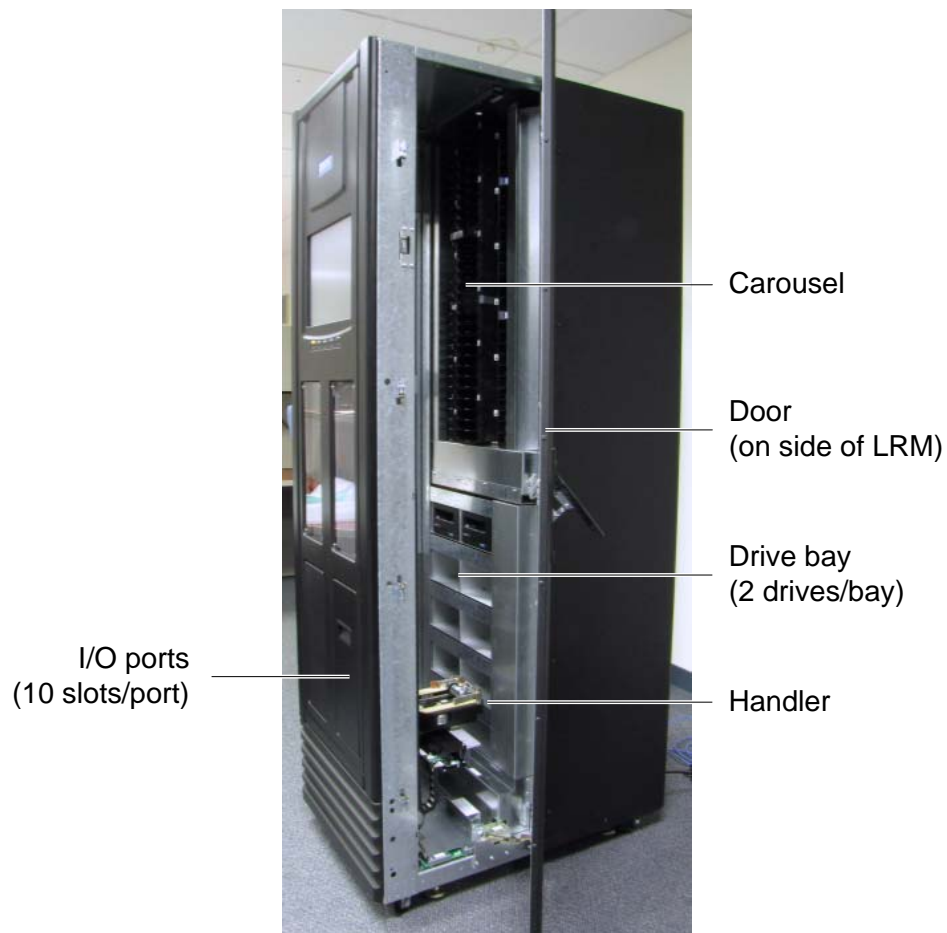

Figure 1-3 Inside view of the LRM

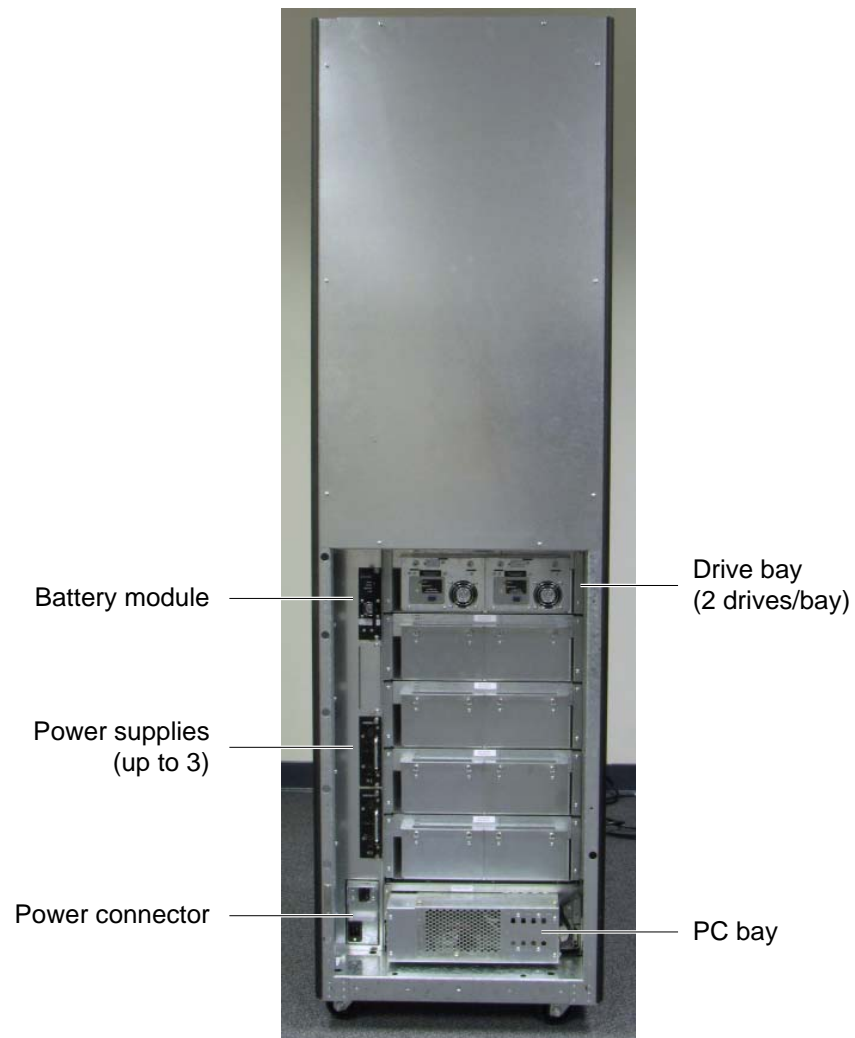

Figure 1-4 Rear view of the LRM

1.2.1 PC Bay

[Figure 1-4](#) shows the location of the PC bay at the rear of the LRM. The PC bay houses the system controller and slides in and out of the LRM for servicing.

Power System

[Figure 1-5](#) shows the power components accessible from the rear of the LRM. An optional redundant power input module is also available.

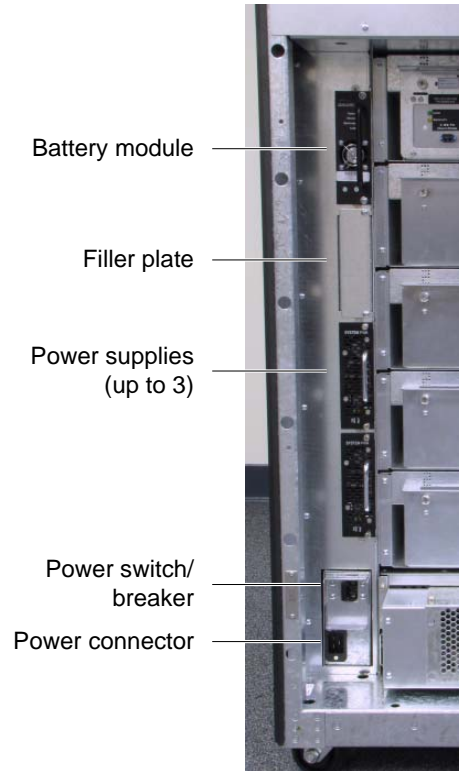

Figure 1-5 Power components

System Controller

Shown in [Figure 1-6 on page 1-7](#), the system controller consists of a Linux-based computer that controls the library. The system controller:

- Controls the operation of the distributed control boards (DCBs)
- Manages all communications between the XLS and the host applications
- Maintains an up-to-date cartridge inventory
- Hosts the X-Link management interface
- Provides a control interface to the tape drives for configuration and servicing

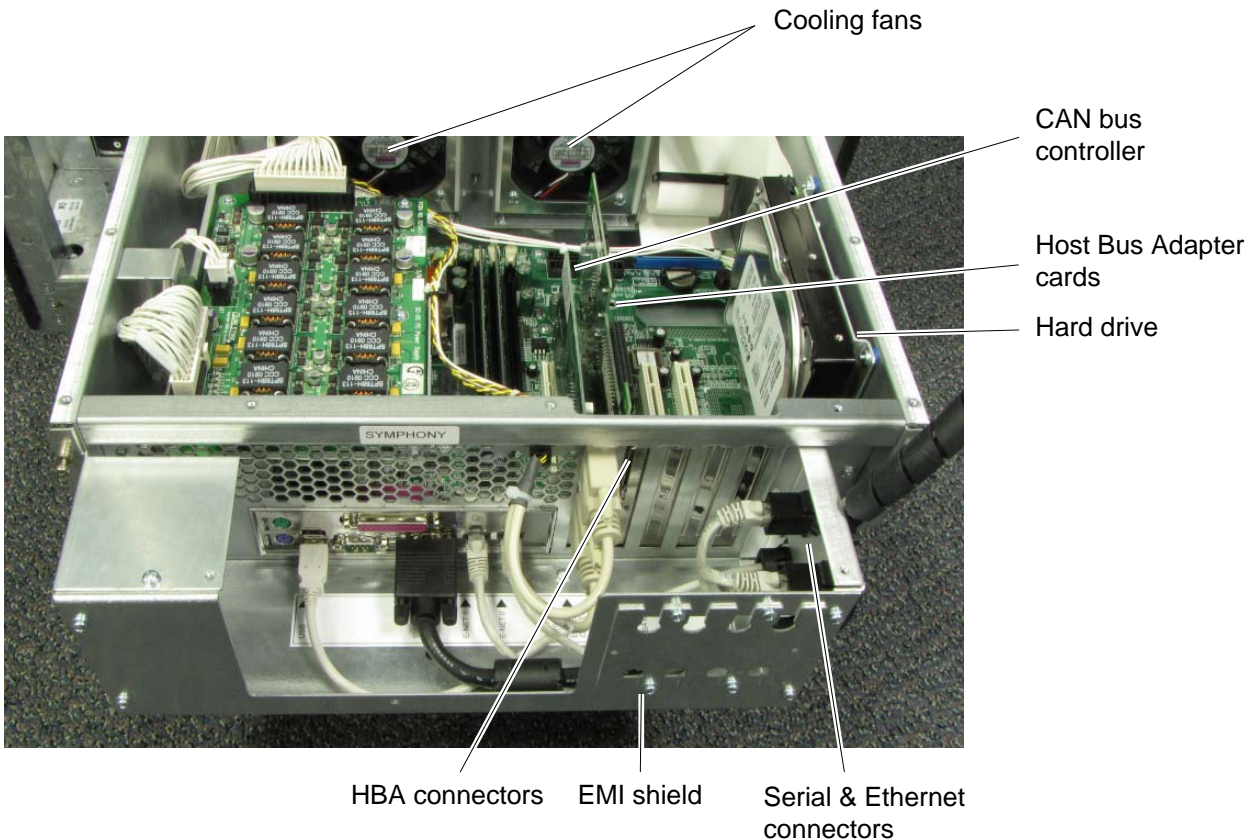

Figure 1-6 System controller components in the PC bay

1.2.2 Touch Screen and LEDs

Shown in [Figure 1-7](#), each LRM includes a touch screen, used to display the X-Link Management Interface, and five LEDs.



Figure 1-7 Touch screen and status LEDs (X-Link log-in screen displayed)

Touch Screen

The 15-inch LCD touch screen on the front of the LRM allows for local control and monitoring of library operations. The touch screen receives power from the PC power supply in the system controller and communicates with the system controller using a USB interface.

X-Link Management Interface

The X-Link management interface can be accessed locally from the touch screen or remotely over Ethernet using a standard Internet browser. The interface and available functions are the same regardless of how they are accessed. The X-Link Home page, shown in [Figure 1-8 on page 1-9](#), provides information about library status and provides an access point to library management tasks.

The screenshot displays the X-Link Home interface. At the top, there is a navigation bar with the QUALSTAR logo, 'X-LINK INTERFACE', and 'Help' and 'Logout' buttons. Below this is a blue header with a 'Refresh' button. The main content area is titled 'X-LINK HOME' and includes the COMPASS ARCHITECTURE logo, the system ID 'qualstarxls XLS-810240 1002264X', and a link to 'Change Touch Screen Option'. The 'Logical Mode' section contains links for 'Logical Library View', 'Service View', 'Administrator View', 'Show All', and 'Create Custom View', along with the date 'Thu Feb 18 10:32:29 MST 2010' and an 'Autorefresh' checkbox. The 'Logical Libraries' section features a status bar indicating 'All Libraries Online, All Libraries Ready' and 'Doors: All Closed, Locked I/O Ports: All Closed Drives Offline: 0'. It also shows 'Event Counts (All Libraries)' with 'Fault: 0' and 'Alert: 0', and a 'Last 24 Hours: 3000' counter. Below this are tabs for 'Logical Mode', 'Physical Mode', 'Lock Doors', and 'Unlock Doors'. A table lists logical libraries with columns for Name, Status, Events (Fault / Alert / 24h), Tapes (Total), Storage (Slots / Tapes), Tape Drives (Drives / Tapes, Offline), and I/O Ports (Slots / Tapes, Status). The 'qualstarxls' library is selected and shows 'Online / Ready' status with 0 faults/alerts, 10 tapes, 245 slots/5 tapes, 2 drives/0 offline, and 10 slots/5 I/O ports. Below the table are 'Export options' for CSV, Excel, and XML. At the bottom, there are two columns of links: 'Media and Tape Drives' (View/Open I/O Port, Tape Drives, View Inventory, Move Media, Import Media, Export Media) and 'Administration and Configuration' (Event Log, Offline Logical Library, Online Logical Library, Library Specifications, Contact Information, Administrator Information, Nexus, Create a New Library, Delete Logical Library). A second 'Refresh' button is located at the bottom right of the main content area.

Figure 1-8 X-link Home page (Logical Libraries View selected)

LEDs

The LEDs on the front panel indicate the library's operational status at a glance. Status LEDs are also included on the back of each tape drive assembly and each power supply.

1.2.3 Robotic Handler and Barcode Reader

Shown in [Figure 1-9 on page 1-10](#), the robotic tape handler within each LRM can access cartridges anywhere on the front wall or the rotating carousel. It can also access slots on

the carousel of an attached MEM. The handler is controlled by the medium changer interface and shared by all host software applications on a first-come, first-served basis.



Figure 1-9 Robotic handler (shown reaching into an attached MEM)

Gripper Assembly

The gripper assembly is the part of the handler that actually picks and places the cartridges in the storage slots and tape drives. The gripper moves along four axes, as follows:

- The *X-axis* is the horizontal axis.
- The *Y-axis* is the vertical axis.
- The *Theta-axis* is the rotating axis that allows the gripper assembly to reach cartridge slots on the front, back, and sides of the cabinet.
- The *Z-axis* is the in-and-out axis. The fingers on the gripper assembly are opened and closed using a solenoid and use a sensor to determine if they are open or closed.

Barcode Reader

Located on the gripper assembly, the barcode reader performs two types of scans:

- **Fiducial scan.** *Fiducials* are the black and white triangles mounted on either side of every cartridge magazine (see [Figure 1-10 on page 1-11](#)). There is also a

fiducial located on the tape drive calibration cartridge, which is stored in one of the five reserved slots.



Figure 1-10 Cartridge magazine with two fiducials

During a *fiducial scan*, the handler moves up and down and across the cartridge slots and I/O ports until the barcode reader detects the fiducials. It also inserts the calibration cartridge into each tape drive. Once all the fiducials have been detected, the library can calculate the exact position of every storage slot and tape drive in a process known as *calibration*. Fiducial scans and calibration are required only when the library is installed or when certain service procedures are performed.

- **Inventory scan.** During an *inventory scan*, the barcode reader scans each slot to determine which ones contain cartridges. It also scans the barcode labels on the cartridges to establish and maintain its cartridge inventory. The system controller stores the cartridge inventory in a database and makes it available to the host applications.

Barcode labels must conform to the ANSI/AIM BCI-1995, Uniform Symbol Specification (USS-39). Detailed specifications for XLS barcodes and labels can be found in Qualstar Product Information Note 040, “XLS, RLS, and TLS Barcode Labels.” To obtain this document, go to www.qualstar.com and click on the Support tab. Pre-printed barcode labels, which are both human- and machine-readable, are available from a number of sources.

1.2.4 Tape Drives

Tape Drive Assemblies

Shown in [Figure 1-11](#), an XLS tape drive assembly consists of an LTO tape drive enclosed in a drive carrier.



Figure 1-11 Fibre Channel tape drive assembly (rear view)

Two models of tape drives are available: SCSI tape drive assemblies include dual SCSI HD68 connectors and a single status LED, while Fibre Channel tape drive assemblies include a duplex LC multi-mode Fibre Channel receptacle and three LEDs.

Depending on the capabilities of the application software being used, the Fibre Channel tape drive assemblies can be removed and replaced without powering down the library. The library automatically detects the presence of a new tape drive.

Drive Bays

[Figure 1-12](#) shows the view of several drive bays through the open door. Each drive bay can hold up to two tape drive assemblies, which are installed from the rear of the LRM.



Figure 1-12 View of drive bays through the open door

For safety reasons, all tape drive or drive filler assemblies (see [Figure 1-13](#)) must be installed in each drive bay in order for the library to operate. If the library detects that one of the positions is empty, it disables the handler until another tape drive or drive filler assembly is installed.



Figure 1-13 Drive filler assembly

1.2.5 I/O Ports

As shown in [Figure 1-14](#), I/O ports on the front of the LRM allow cartridges to be imported or exported without opening the door(s) and interrupting XLS operations. Each I/O port holds 10 cartridges in a removable magazine. Depending on the model, the XLS can include one or two I/O ports. For each I/O port that is not installed, the library includes 10 additional cartridge storage slots, called *fixed port assemblies*.



Figure 1-14 I/O port

Each I/O port uses a removable magazine suitable for long-term storage. See [Figure 1-15](#).



Figure 1-15 I/O port magazine

1.2.6 Cartridge Slots

[Table 1-1](#) lists the cartridge capacities of each XLS model.

Location	Number of Cartridge Slots	
	XLS-810160	XLS-810240
Carousel slots	155	235
Fixed port slots	up to 10 (assumes only one I/O port is installed)	up to 10 (assumes only one I/O port is installed)
Total slots	up to 165	up to 245
MEM2 adds	XLS-85000 adds 517	XLS-85000 adds 517
Expansion pod adds	116	116

Table 1-1 Available cartridge slots

1.2.7 Door and Light Curtain Sensors

Door

The XLS-810160 and XLS-810240 have a single door on the right side. The XLS-85000 MEM2 has a single door that opens on the front. All doors have windows for viewing robot operations and the LRM's have front windows. There are also viewing windows on the side panels.

Light Curtain Assembly

The *light curtain*, also known as the “Inventory Sentry,” consists of a series of infrared emitters and detectors arrayed throughout the XLS. The emitters project small beams of infrared light that is not visible to the naked eye toward corresponding detectors.

The curtain of light formed by the emitters and detectors allows the XLS to precisely monitor all areas within the LRM and MEM cabinets, as follows:

- The beams of light at the rear of the cabinet can detect whether a cartridge is protruding from a slot. If the door is closed and one of these beams of light is broken, the XLS prevents the handler from moving to avoid hitting a protruding cartridge.
- The beams of light curtain at the front of the cabinet can detect when someone reaches into the cabinet. If the door is open and one of these beams of light is broken, the XLS detects and logs a potential inventory violation and automatically scans the cartridges and drives in the affected area as soon as the door is closed.

1.3 Media Expansion Module (MEM)

Shown in [Figure 1-16](#) the Media Expansion Module (MEM) includes a rotating motor-driven carousel containing cartridge slots. The XLS-85000 (MEM2) can store up to 517 cartridges. The XLS-810160/810240 can be expanded by adding one XLS-85000 MEM to its left side.

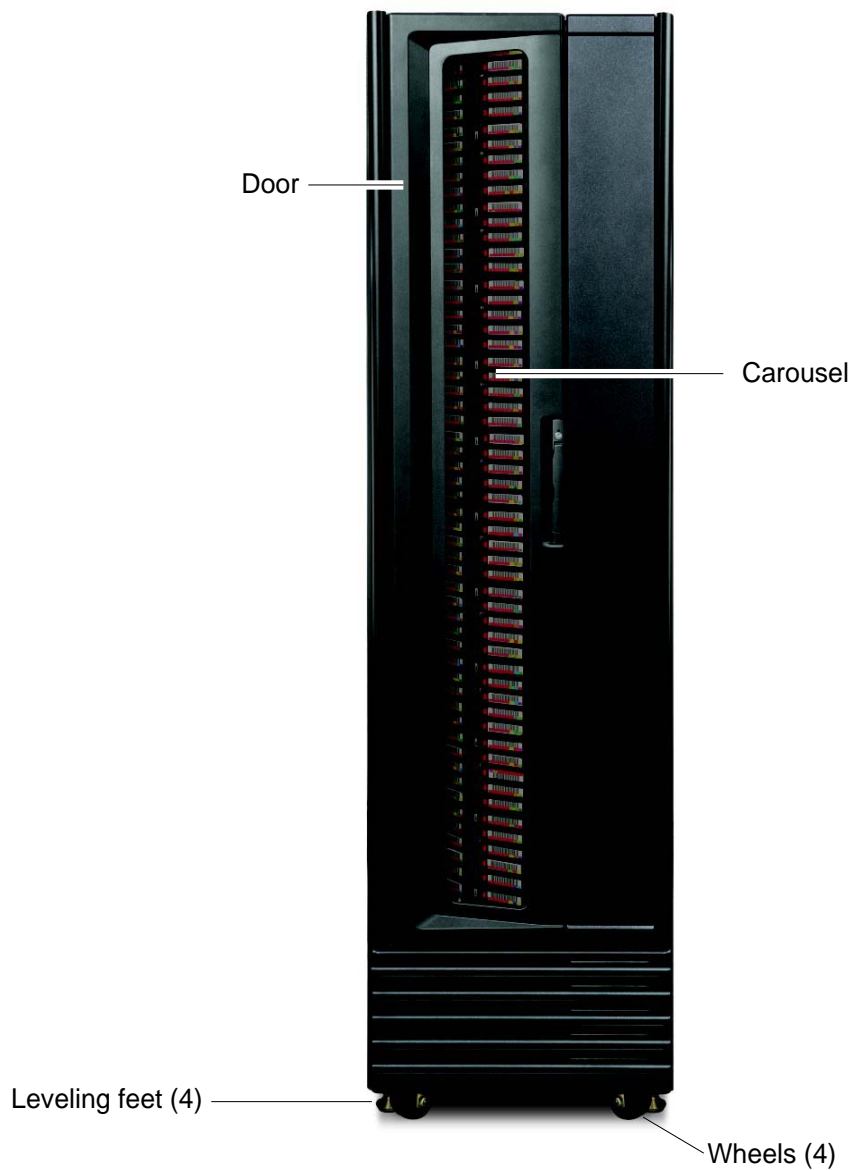

Figure 1-16 Front view of an XLS-85000 Media Expansion Module (MEM2)

A MEM derives its power and control from an attached LRM. The carousel can rotate in either direction and the handler from an attached LRM can reach into a MEM to pick, place, and scan the barcode of any cartridge.

1.4 How This Manual Is Organized

[Table 1-2](#) is a quick reference for locating the information in this manual.

Refer to...	For...
Chapter 2, “Preparing for Installation”	Overview of the installation process, including a check list of required and optional components and accessories
Chapter 3, “Unpacking the XLS”	Instructions for unpacking the XLS and its components
Chapter 4, “Installing the LRM”	Instructions for setting up the LRM
Chapter 5, “Installing a MEM”	Instructions for attaching a MEM2 to the LRM (optional)
Chapter 6, “Installing an Expansion Pod”	Instructions for attaching an expansion pod (optional)
Chapter 7, “Installing the Tape Drive Assemblies”	Instructions for installing tape drives in the LRM
Chapter 8, “Connecting the XLS”	Instructions for connecting the XLS and tape drives to SCSI or Fibre Channel host computers
Chapter 9, “Applying Power and Logging Into X-Link”	Instructions for performing the initial power on and logging into X-Link from the touch screen
Chapter 10, “Configuring the Physical Library”	Instructions for setting up the physical library, including information about connecting the XLS to a standalone computer or Ethernet network
Chapter 11, “Setting Up Logical Libraries”	Instructions for creating logical libraries from X-Link
Chapter 12, “Loading Cartridges”	Instructions for loading cartridges into the XLS
Chapter 13, “Scanning the Fiducials and Inventory”	Instructions for scanning the fiducials and cartridge inventory
Chapter 14, “Testing the Installation”	Instructions for bringing the logical libraries online and testing the software applications to ensure that all components are working and communicating correctly
Appendix A, “Library Addresses”	Graphics showing the physical addresses for all cartridge slot and tape drive locations
“Glossary”	Definitions of the specialized terminology used in this manual
“Index”	Alphabetized quick reference for specific topics and terms

Table 1-2 Information included in the *XLS Library Installation Manual*

1.5 Conventions Used in This Manual

This section lists the terminology, typographic, and organizational conventions used in this manual.

1.5.1 Terminology

For clarity and compliance with the SCSI standard, the library control interface of the XLS is referred to as the *medium changer*. Note that the medium changer is different than the *handler*, which is simply the robotic mechanism within the XLS that picks and places the cartridges.

Refer to the [“Glossary”](#) for the definitions of other specialized terminology.

1.5.2 Typographic Conventions

This manual uses the following typographic conventions:

- For X-Link, options that can be selected are shown in **bold face**. For example:
 - Select **Online Logical Library**
- For X-Link, names of buttons that can be pressed are shown in **bold face**. For example:
 - Press **Done**
 - Press **Unlock Doors**
- For X-Link, names of fields or drop-down lists are shown in **bold face**. For example:
 - **Column** and **Row** drop-down lists
- Specialized terminology is introduced in *italic face*. For example:
 - Each physical library can be partitioned into one or more *logical libraries*.

1.5.3 Safety Notices

This manual may include four types of notices.

Warnings and Caution Notices

To avoid personal injury, damage to the equipment, or loss of data, closely follow the operating instructions and maintenance procedures described in this manual. Pay special attention to the information in Warning and Caution notices, as described below:

WARNING!

Personal injury may result if you do not fully comply with the handling, operating, or service instructions found in a Warning notice.

CAUTION

Equipment damage or loss of data may result if you do not fully comply with the handling, operating, or service instructions found in a Caution notice.

Important Notices and Notes

Important notices and notes provide additional information and tips, as described below:

Important: Important notices provide tips for completing a procedure or information that is essential to the understanding of a topic.

Note: Notes provide additional information related to the topic being discussed.

1.6 For More Information

This section provides information about related manuals and how to contact Qualstar.

1.6.1 Related Manuals

For more information about the XLS library, refer to the manuals in [Table 1-3](#), which can be downloaded onto any computer connected to the XLS. The manuals are in Adobe Acrobat PDF format.

Refer to...	Part number	For...
<i>XLS-810160/810240 Tape Library Product Specification</i>	501800	Specifications for the XLS-810160 and XLS-810240
<i>XLS-810160/810240 Tape Library Site Planning Guide</i>	501804	Information for preparing a site for XLS-810160/810240 installation
<i>XLS-810160/810240 Tape Library User's Guide</i>	501803	Instructions for operating the XLS-810160/810240
<i>XLS Library Interface Manual</i>	501611	Information software developers need to control the XLS using a software application
<i>XLS-810160/810240 Tape Library Technical Service Manual</i>	501810	Information authorized service personnel need to maintain the XLS and replace XLS components Note: The Qualstar XLS Library is a sophisticated, state-of-the art computer peripheral. It must be serviced by authorized service technicians who are experienced with the operation and maintenance of tape libraries and who have read and understood the <i>XLS-810160/810240 Tape Library Technical Service Manual</i> .

Table 1-3 Related manuals

1.6.2 Accessing the Online Manuals

Important: You cannot access the online manuals from the touch screen. To access the PDF files for the manuals, you must connect the XLS to a standalone or networked computer that has Adobe Acrobat or Adobe Reader installed.

To access and download the manuals, follow these steps:

1. Follow the instructions in [Section 10.1 on page 10-1](#) to connect the library to a standalone computer or Ethernet network.
2. Open any of the supported Internet browsers on an attached computer.

- In the address field for the browser, type **`http://qualstarxls/manuals/index.html`**, where *qualstarxls* is the default name for the physical library. See [Figure 1-17](#).

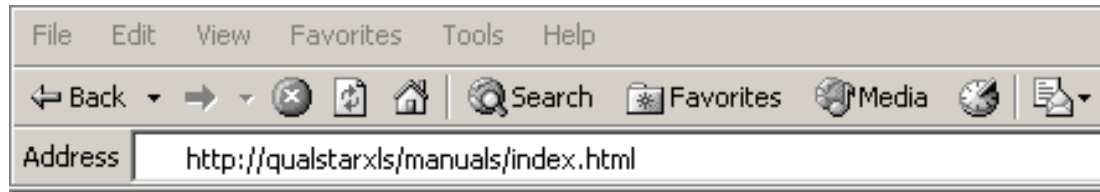

Figure 1-17 Accessing the online manuals (Internet Explorer shown)

Important: If you have changed the name for the physical library, be sure to use the new name instead of *qualstarxls*.

- Press **Enter**. The Download Manuals page opens, as shown in [Figure 1-18](#).

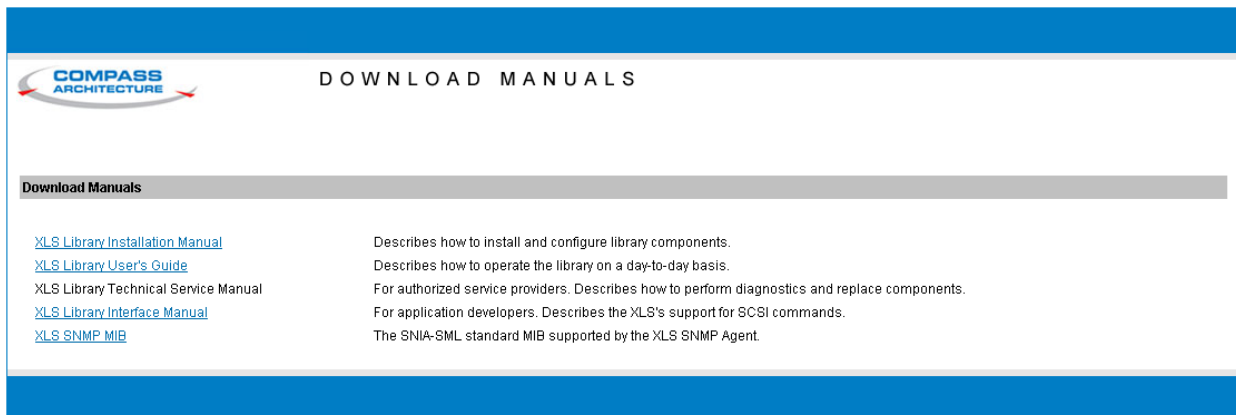

Figure 1-18 Download Manuals page

5. Select the manual you are interested in. Assuming that Adobe Acrobat or Acrobat Reader is installed on your system, the PDF file opens. See [Figure 1-19](#).

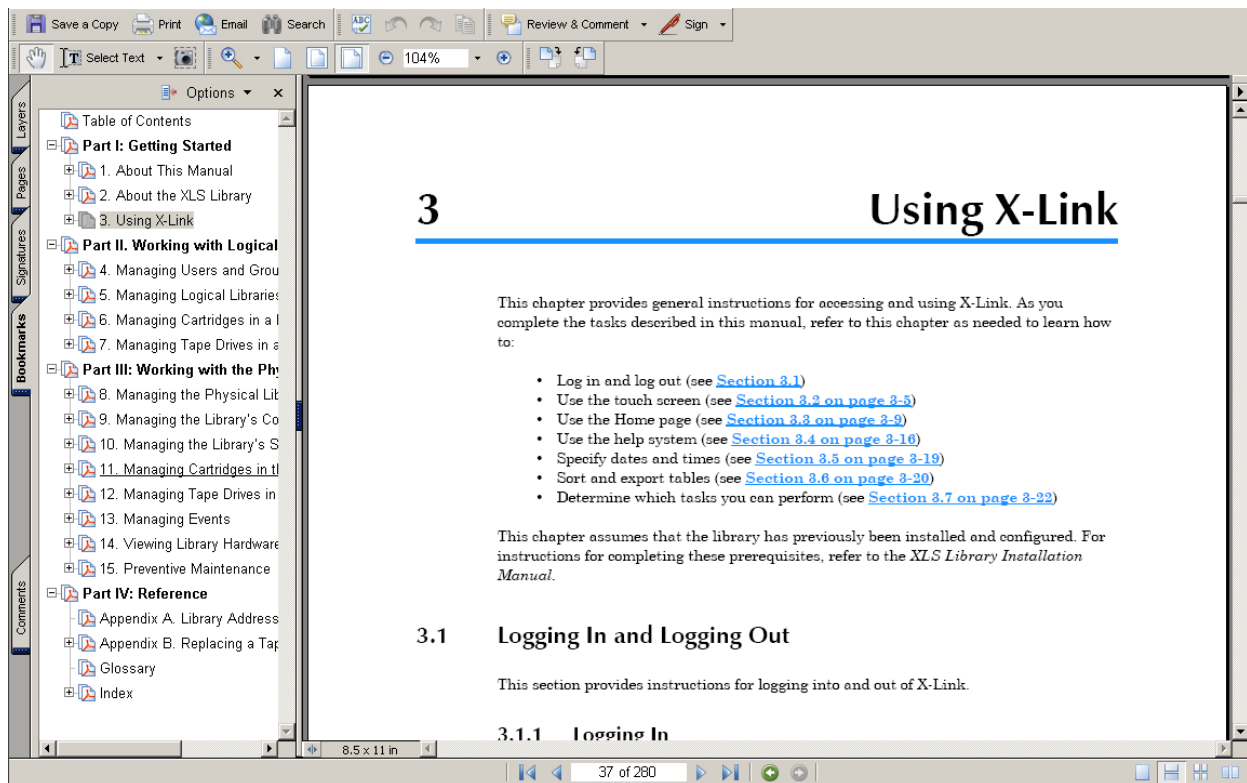

Figure 1-19 PDF file of example manual opened in browser window

1.6.3 Contacting Qualstar

If you have questions about the XLS library, contact an authorized reseller or Qualstar Technical Support.

Qualstar Corporation

1267 Flynn Road
Camarillo, CA 93012

Monday - Friday 7:00 AM - 4:00 PM PST

Phone: (805) 416-7055
Toll Free: (877) 886-2758

After hours

Phone: (805) 583-7744
option 4

E-mail: support@qualstar.com

E-mail: sales@qualstar.com

www.qualstar.com

2

Preparing for Installation

This chapter summarizes the XLS installation process and provides a check list of the components, options, and accessories you need to complete the installation.

Important: Before starting the installation, be sure that you have access to any planning diagrams or documents created when determining what XLS equipment to order. You will need to refer to these documents as you install the tape drives and cartridges, connect the SCSI or Fibre Channel cables, and configure the logical libraries.

2.1 Installation Overview

[Figure 2-1](#) summarizes the steps in XLS installation.

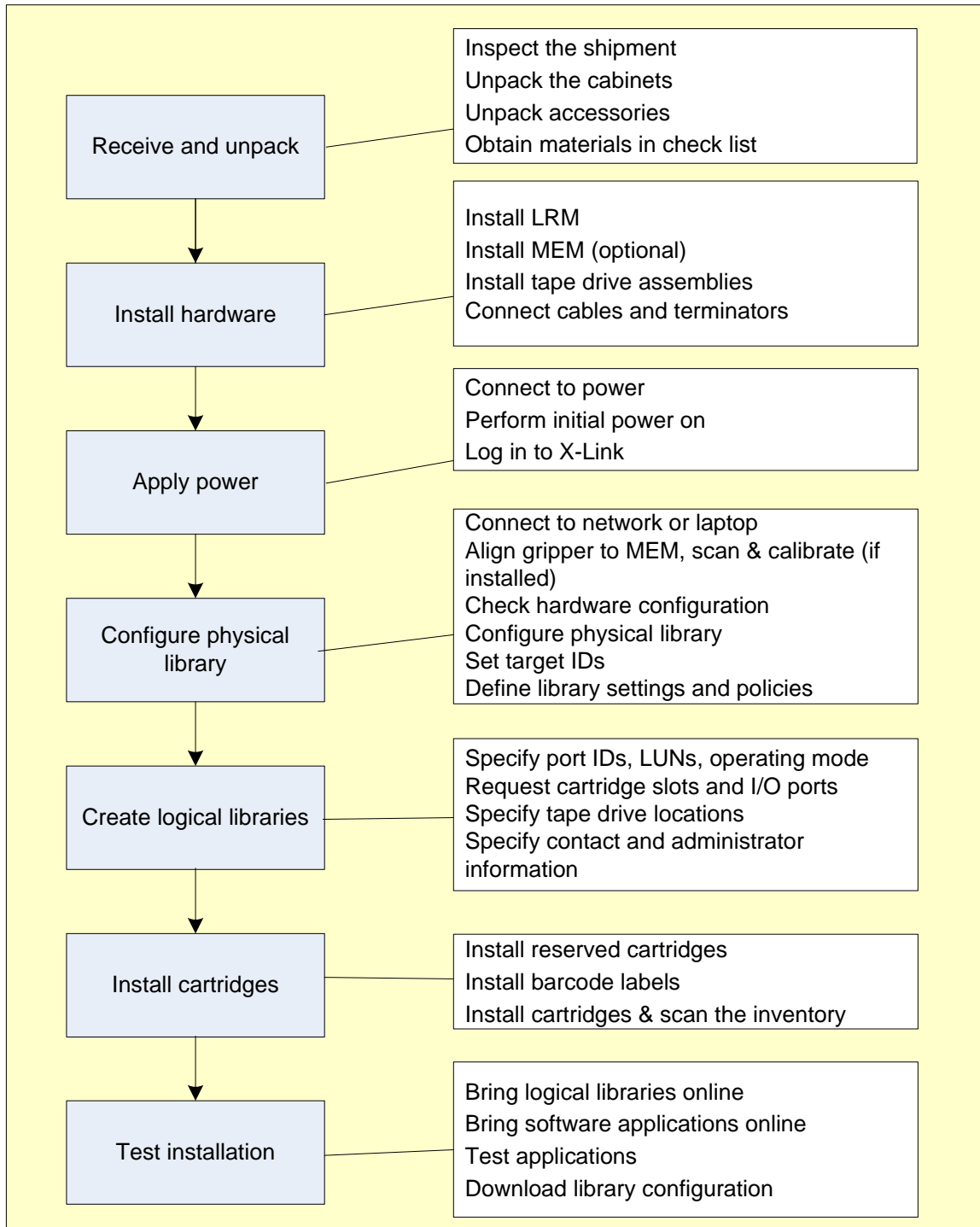

Figure 2-1 Steps in XLS installation

As shown in the figure, installation includes the following steps:

1. Unpack the XSL cabinets and accessories. For instructions, see [Chapter 3, “Unpacking the XLS.”](#)
2. Install the LRM. For information, see [Chapter 4, “Installing the LRM.”](#)
3. Attach a MEM (optional). For information, see [Chapter 5, “Installing a MEM.”](#)
4. Attach an expansion pod (optional). For information, see [Chapter 6, “Installing an Expansion Pod.”](#)
5. Install the tape drive assemblies. For information, see [Chapter 7, “Installing the Tape Drive Assemblies.”](#)
6. Connect the library and the tape drives to one or more SCSI buses or Fibre Channel networks. For information, see [Chapter 8, “Connecting the XLS.”](#)
7. Connect the library to power and perform the initial power on. Then, log into X-Link from the touch screen. For information, see [Chapter 9, “Applying Power and Logging Into X-Link.”](#)
8. Connect the library to a network or standalone computer, align the gripper to the MEM (if installed), check the hardware configuration, and configure the physical library and network connections. For information, see [Chapter 10, “Configuring the Physical Library.”](#)
9. If you will be operating the XLS with more than one logical library, create additional logical libraries, as follows:
 - Specify information about the logical library connections
 - Specify the tape drive locations
 - Specify how many cartridge slots are required
 - Specify how many I/O ports are required

For information, see [Chapter 11, “Setting Up Logical Libraries.”](#)

10. Apply barcode labels and install the cartridges. For information, see [Chapter 12, “Loading Cartridges.”](#)
11. Scan the fiducials and cartridge inventory. For information, see [Chapter 13, “Scanning the Fiducials and Inventory.”](#)
12. Bring the logical libraries and software applications online, test the setup, then back up the configuration. For information, see [Chapter 14, “Testing the Installation.”](#)

2.2 Installation Check List

After the XLS order is placed, Qualstar builds the library to the requested specifications and preinstalls the drive bays, cartridge slots, I/O ports, Host Bus Adapters (HBAs), and the power supplies. The tape drive assemblies, and the cartridges must be installed at the customer's site.

[Table 2-1](#) provides an annotated check list of XLS components, options, and accessories, so you can ensure all required parts are available before starting the installation.

✓	Item	Provided by	Notes
	LRM	Qualstar	Built and pre-tested to customer specifications; includes variable number of drive bays, I/O ports, power supplies, and HBAs.
	MEM	Qualstar	As an option, one XLS-85000 MEM can be attached to the left side of an XLS-810160 or XLS-810240.
	Expansion pods	Qualstar	As an option, one expansion pod can be attached to the left side of an XLS-810160 or XLS-810240.
	Tape drive assemblies	Qualstar	The tape drives are installed in drive carriers at the factory.
	Drive filler assemblies	Qualstar	All unused tape drive locations require drive filler assemblies, which are installed in the library before shipping.
	Terminators for SCSI tape drives	Qualstar	The accessory box includes a terminator for each SCSI tape drive.
	I/O port magazines and covers	Qualstar	The accessory kit includes a magazine for each I/O port. Additional I/O port magazines and covers are available for long-term cartridge storage.
	Power cord	Qualstar	The accessory kit includes the appropriate power cord for the input voltage and current.
	Door keys	Qualstar	The accessory kit includes keys to lock the door.
	Stylus for touch screen	Qualstar	The accessory kit includes a stylus that you can use to control the touch screen.
	Calibration cartridge	Qualstar	The accessory kit includes a calibration cartridge, which is required to calibrate the tape drive locations.

Table 2-1 Installation check list

✓	Item	Provided by	Notes
	Uninterruptible power supply (UPS)	Customer	The battery backup module in the power/PC bay provides enough backup power to safely shut down the XLS if an unexpected power failure occurs. However, the battery module does not provide adequate power to protect the tape drives. For this reason, Qualstar recommends that you connect the XLS to an external UPS. Be sure that the UPS uses "APC Smart Signaling" protocol.
	UPS cable	Customer	Use a UPS Communication Cable Smart Signaling (part number 940-0024).
	Data and cleaning cartridges	Customer	Refer to the software application and tape drive documentation for data and cleaning cartridge requirements. In addition to any cleaning cartridges required for each logical library, four cleaning cartridges are needed for the system-reserved slots.
	Barcode labels	Customer	Barcode labels must conform to the ANSI/AIM BCI-1995, Uniform Symbol Specification (USS-39). Detailed specifications for XLS barcodes and labels can be found in Qualstar Product Information Note 040, "XLS, RLS, and TLS Barcode Labels." To obtain this document, go to www.qualstar.com and click on the Support tab. Pre-printed barcode labels, which are both human- and machine-readable, are available from a number of sources.
	SCSI cables	Customer	Refer to the installation plan to determine how many SCSI cables are required. The tape drives use HD68 connectors, while the HBAs use VHDCI connectors.
	Fibre Channel cables	Customer	Refer to the installation plan to determine how many Fibre Channel cables are required. The tape drives and the HBAs in the XLS both use multimode 62.5/125 fiber optic patch cables with duplex LC connectors.
	Ethernet cables	Customer	You must supply a CAT5e or better, straight-through Ethernet cable to connect the library to an Ethernet network for remote operation.
	Bullet-nose alignment pins (2)	Qualstar	Shipped with the MEM
	5/16 x 3/4-inch hex bolts (6)	Qualstar	Shipped with the MEM
	Gripper alignment cartridge	Qualstar	Qualstar part number: 620059; shipped with the MEM
	5/16-inch hex wrench	Qualstar	Included in the accessory kit. Used to remove the shipping restraints from the unit
	3/4-inch open-end wrench	Installer	
	3/8-inch Allen wrench	Installer	

Table 2-1 Installation check list (*continued*)

2.2 Installation Check List

✓	Item	Provided by	Notes
	5/16-inch Allen wrench	Installer	
	Ratchet with 1/2-inch deep socket	Installer	
	#2 Phillips screwdriver	Installer	
	5/32-inch Allen wrench	Installer	
	1/4-inch Allen wrench	Installer	
	Wire cutters or scissors	Installer	
	Precision level	Installer	
	3/16-inch hex wrench	Installer	For installing the MEM
	5/32-inch hex wrench	Installer	For installing the MEM

Table 2-1 Installation check list (*continued*)

3

Unpacking the XLS

This chapter provides instructions for unpacking the XLS library and components. This chapter is intended as a supplement to the *XLS Library Site Planning Guide* (501804).

WARNING!

Not including tape drives or cartridges, the LRMs weigh up to 590 lbs (268 kg). To avoid injury or equipment damage, use a pallet jack or forklift when moving the packaged XLS.

Required tools and equipment: Obtain the following:

- Phillips screwdriver
- 1/2-inch socket or open-end wrench
- 5/16-inch hex wrench (included in the accessory box)
- Scissors

Procedure overview: Unpacking the XLS involves the following steps:

- Inspecting the shipment (see [Section 3.1](#))
- Unpacking the XLS (see [Section 3.2 on page 3-3](#))

3.1 Inspecting the Shipment

Before unpacking the cartons, inspect the entire shipment, as follows:

1. Check the packing lists on each container to ensure you have received all requested equipment, including
 - Correct model of Library Resource Module (LRM)
 - Media Expansion Module (MEM2), if ordered
 - Expansion pod, if ordered
 - Correct number and type of tape drive assemblies and drive filler assemblies
 - Other accessories, including cartridges and barcode labels

3.1 Inspecting the Shipment

2. Inspect the Tip (N) Tell indicators on each container to determine if the shipment was tipped during transport. See [Figure 3-1](#).



Figure 3-1 Example Tip (N) Tell indicators

3. Inspect the cartons and pallets for obvious damage (for example, punctures or water stains).
4. Report any damage to the carrier.

Important: You must report any damage to the carrier before unpacking the XLS.

3.2 Unpacking the XLS

[Table 3-1](#) provides an overview of unpacking the XLS.

Step	Task	Refer to...
1	Remove the packaging	Section 3.2.1
2	Remove the web straps	Section 3.2.2 on page 3-5
3	Attach ramps to the pallet	Section 3.2.4 on page 3-11
4	Remove the shipping restraints	Section 3.2.3 on page 3-7
5	Roll the unit into position	Section 3.2.5 on page 3-13

Table 3-1 Overview of unpacking the XLS

3.2.1 Remove the Packaging

To remove the packaging, follow these steps:

1. Using a pallet jack or forklift, move the shipping containers as close to the desired installation location as possible. Make sure there is adequate space to roll each unit off its pallet and into position.

CAUTION

To prevent interference with the optical barcode reader, light curtain sensors, and cartridge present sensors, do not install the XLS in areas exposed to direct sunlight.

2. Remove the plastic sheeting surrounding the cardboard. See [Figure 3-2](#)



Figure 3-2 XLS in plastic sheeting covered shipping carton

3. Lift the cardboard cap off the top.
4. Using a Phillips screwdriver, remove the drywall screws that attach the cardboard to the pallet.

5. Remove the four pieces of cardboard and set them aside. See [Figure 3-3](#).



Figure 3-3 LRM with crating material removed

6. Visually inspect the unpacked equipment for obvious shipping damage, such as dented or scratched surfaces. Report any damage to the carrier.

3.2.2 Remove the Web Straps

To remove the four web straps, follow these steps:

1. Locate the ratchet on each of the four straps.

2. Push down on the release lever, then lift up on the latch to detension the strap. See [Figure 3-4](#).



Figure 3-4 Ratchet on the web strap

3. Unhook the strap from the upper and lower eye bolts.
4. Repeat steps 2 and 3 to remove the other straps.
5. Remove the cardboard spacer from the top of the XLS.
6. Using a 1/2-inch socket or open-end wrench, remove the four shipping brackets from the top of the unit. See [Figure 3-5](#).



Figure 3-5 Removing a shipping bracket

7. Lift the plastic sheeting off of the unit.

3.2.3 Remove the Shipping Restraints

The LRMs are bolted to the pallet with four shipping restraints: two in the back and two in the front. The MEMs are also bolted to the pallet with four shipping restraints: two on each side.

XLS-810160 or XLS-810240

To remove the back and front shipping restraints, follow these steps:

1. Locate the two shipping restraints at the back. See [Figure 3-6](#).

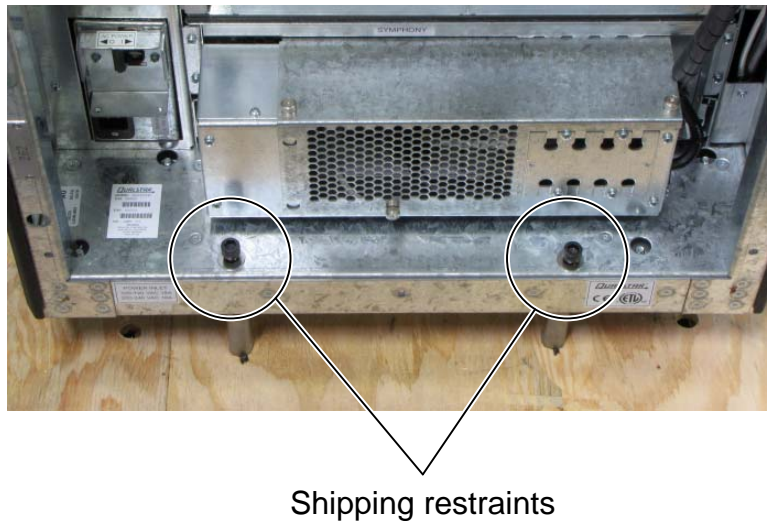

Figure 3-6 Location of the back shipping restraints

2. Using a 5/16-inch hex wrench (included in the accessory box), remove the shipping restraints.
3. Open the door on the right side of the LRM.

4. Locate the two shipping restraints at the front. [Figure 3-7](#) shows the location of the shipping restraint behind the door on the right; the shipping restraint on the left is located under the X-axis.



Shipping restraint

Figure 3-7 Location of the front right shipping restraint

5. Remove the front right shipping restraint.
6. For the left side shipping restraint an assistant will be needed. Using wire cutters or scissors, cut and remove the cable tie that holds the X-axis in place. See [Figure 3-8](#).

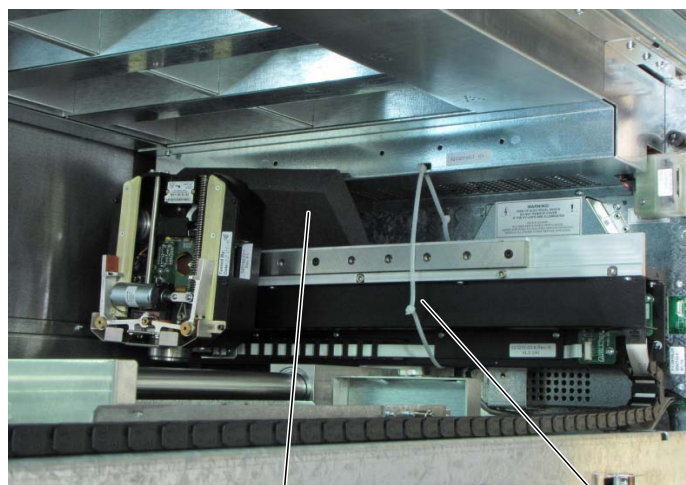

Foam block

Cable tie

Figure 3-8 Location of the cable tie securing the X-axis

7. Remove the foam block from under the X-axis.

8. Lift the X-axis with the help of an assistant and hold it aloft so the shipping restraint is visible as shown in figure [Figure 3-9](#).

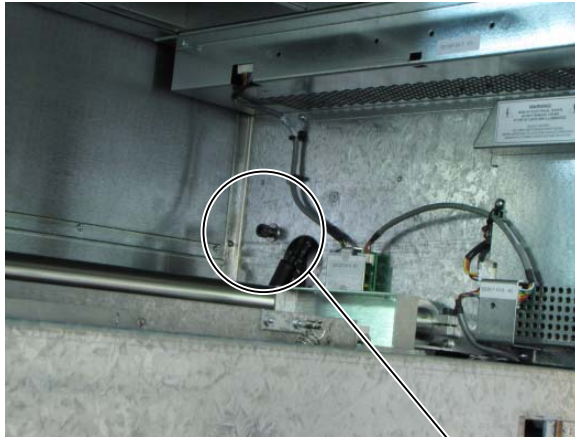

Shipping restraint

Figure 3-9 Location of the front left shipping restraint

9. Remove the shipping restraint.
10. Carefully and slowly lower the X-axis.
11. Close the door.

XLS-85000

1. Locate the shipping restraints attaching the left and right sides of the MEM to the pallet. There are two on either side. See [Figure 3-10](#).

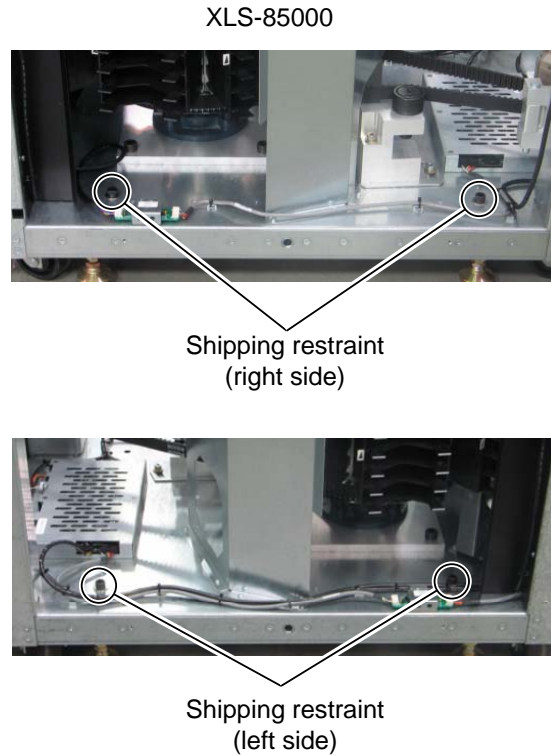

Figure 3-10 Location of shipping restraints on MEMs (right and left sides shown)

2. Using a 5/16-inch hex wrench (included in the accessory box), remove the shipping restraints from both sides.

3.2.4 Attach Ramps to the Pallet

To attach the ramps to the pallet, follow these steps:

1. Using a Phillips screwdriver, remove the drywall screws securing the two ramps. See [Figure 3-11](#).



Figure 3-11 Location of ramps

2. Slide the ramps out from under the unit.

Important: The LRM (XLS-810160/810240) must be turned 90 degrees on the pallet so that the front of the unit is facing the ramps.

3. For the LRM (XLS-810160/810240) only, **using at least two people**, rotate the library on the pallet so that the front is facing the side with the slots where the ramps attach. See [Figure 3-12](#)



On pallet with shipping restraints removed



Rotated 90 degrees so the front is facing the ramps

Figure 3-12 LRM turned in the correct direction

4. Locate the ramp slots on the pallet.

- Important:** The pallet includes different sets of slots. Be sure to use the correct slots for your equipment, as follows:
- **XLS-810160 or XLS-810240:** Use the two narrower-spaced slots directly in front of the front wheels of the LRM.
 - **XLS-85000 MEM2:** Use the wider spaced slots directly in front of the side wheels of the MEM.

5. Attach the ramps to the pallet. See [Figure 3-13](#).



Figure 3-13 Attaching the ramps to the pallet (XLS-810160/810240 shown)

CAUTION

To avoid equipment damage, securely attach the ramps to the pallet and make sure they are positioned directly in front of the wheels.

3.2.5 Roll the Unit into Position

After removing the four shipping restraints, you can roll the unit into position. Follow these steps:

1. Confirm that all of the levelling feet are fully retracted. See [Figure 3-14](#).

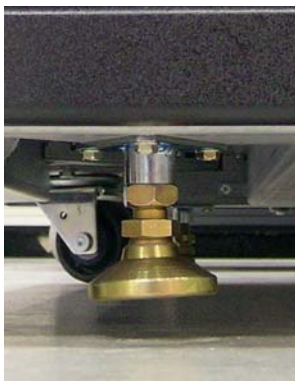

Figure 3-14 Leveling foot in fully retracted position

2. Carefully roll the unit down the ramps and to its intended location.

WARNING!

To avoid injury or equipment damage, use three or more people when rolling the equipment to its final location.

3. Unpack the tape drives, the equipment rack, and all accessory boxes.
4. Remove the plastic sheets from the windows.
5. Save the packing materials in case any of the equipment needs to be moved or returned for service.

CAUTION

Be sure to save all packing materials. To avoid damaging the equipment or voiding your warranty, you must use these materials (or replacements obtained from your vendor) if you ship the XLS to another location.

4

Installing the LRM

This chapter provides instructions for setting up the LRM.

CAUTION

Before installing the LRM, be sure that the library's power switch is off and that the power cord is not attached to the power connector.

Required tools and equipment: Obtain the following:

- 3/4-inch open-end wrench
- Level

Procedure overview: After you have unpacked the LRM and moved it to its intended installation location, installing the LRM involves the following steps:

- Extending the leveling feet (see [Section 4.1](#))

4.1 Extending the Leveling Feet

To extend the leveling feet, follow these steps:

1. Locate the four leveling feet on the base of the LRM.
2. Using a 3/4-inch open-end wrench, loosen one of the leveling feet by turning the jam nut. See [Figure 4-1](#).

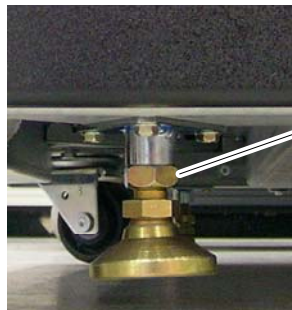

Turn jam nut to
loosen leveling foot

Figure 4-1 Releasing a jam nut

- Using the same wrench, extend the leveling foot until it touches the floor. Then, turn the nut two more complete turns. See [Figure 4-2](#).

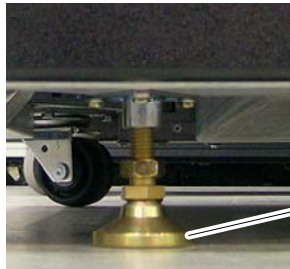

- Lower the foot to the floor.
- Turn the nut 2 more turns.

Figure 4-2 Extending a leveling foot

- Repeat steps 2 and 3 to extend the three other leveling feet.
- Check the alignment by placing a precision level on top of the LRM.

Important: Depending on the floor conditions, you may need to adjust one or more of the leveling feet up or down. Keep checking the alignment until the LRM is at an even level.

- If you are installing a MEM, refer to [Chapter 5, “Installing a MEM.”](#)
or
- If you are not installing a MEM, turn all four jam nuts clockwise until they push up against the frame. See [Figure 4-3](#).

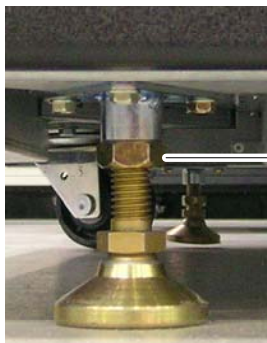

Turn jam nut until
it pushes against
the frame

Figure 4-3 Tightening a leveling foot

5

Installing a MEM

This chapter provide instructions for installing one XLS-85000 Media Expansion Module (MEM2) to the left side of an LRM.

Important: For instructions for attaching a MEM after the LRM has been powered on and configured, refer to the *XLS Library Technical Service Manual*.

Procedure overview: [Table 5-1](#) provides an overview of installing a MEM.

Step	Task	Refer to...
1	Preparing the LRM	Section 5.1
2	Removing the X-axis hard stop	Section 5.2 on page 5-3
3	Releasing the carousel locks	Section 5.3 on page 5-4
4	Connecting the carousel controller cable	Section 5.4 on page 5-6
5	Attaching the MEM to the LRM	Section 5.5 on page 5-8
6	Lowering the leveling feet	Section 5.6 on page 5-9
7	Lowering the carousel supports	Section 5.7 on page 5-11
8	Installing the side panel on the MEM	Section 5.7 on page 5-11

Table 5-1 Overview of installing a MEM

Required tools and equipment: Make sure you have the following:

- 3/4-inch open-end wrench
- #2 Phillips screwdriver
- 3/8-inch Allen wrench
- 5/16-inch Allen wrench (right-angled, if possible)
- 5/32-inch Allen wrench
- 1/4-inch Allen wrench
- Precision level
- Two bullet-nose alignment pins (shipped with the MEM)
- Six 5/16 x 1/2-inch socket head screws (shipped with the MEM)
- Wire cutters or scissors

5.1 Preparing the LRM

To prepare the LRM, follow these steps:

1. On the left side of the LRM, locate the two Phillips screws at the base of the side panel.
2. Using a #2 Phillips screwdriver, remove the two screws. See [Figure 5-1](#).

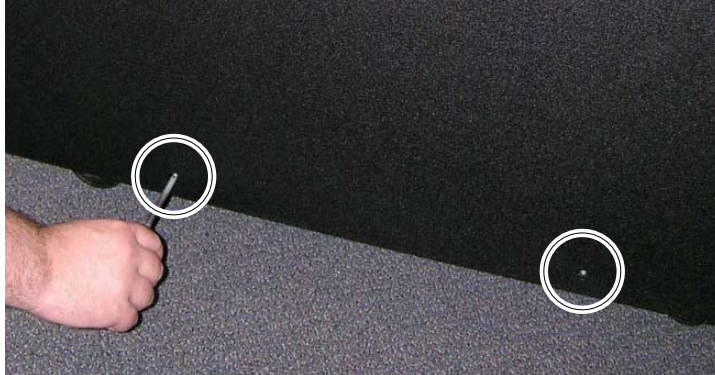

Figure 5-1 Removing the screws from the side panel

3. Carefully slide the panel up until you can lift the hooks out of the corresponding slots on the frame. See [Figure 5-2](#).



Figure 5-2 Removing a side panel

4. Set the screws and the side panel aside—you will install these on the MEM.

5. On the exposed side of the LRM, locate the carousel controller cable. See [Figure 5-3](#).



Figure 5-3 Carousel controller cable on the side of the LRM

6. Cut the tie wraps holding the cable to the frame.

5.2 Removing the X-Axis Hard Stop

When shipped, the X-axis (horizontal axis) on the handler includes two inner and two outer “hard stops,” which are simply #10 cap screws located at each end of the X-axis. See [Figure 5-4](#).

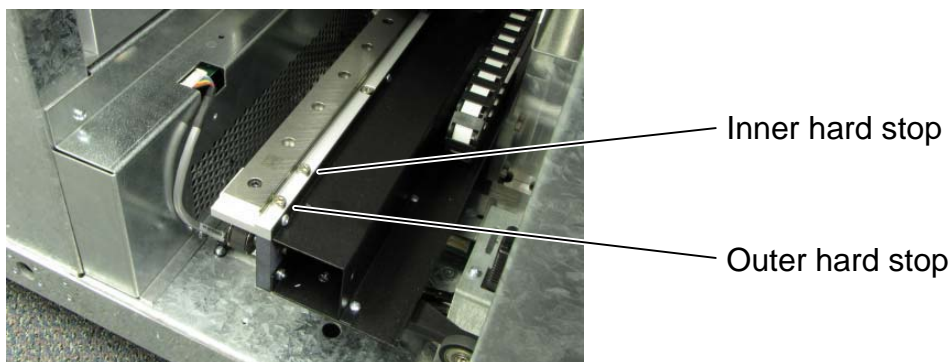

Figure 5-4 Outer and inner hard stops on the handler's X-axis (left side shown)

When the inner hard stops are installed, the handler is prevented from traveling too far to the left and right. When an inner hard stop is removed, the handler can reach into an attached MEM.

You need to remove the inner hard stop on the left side where you will install the MEM.

CAUTION

To avoid damage to the equipment, never remove the two outer stops.

To remove an inner hard stop, follow these steps:

1. You will install a MEM to the left of the LRM, so locate the inner hard stop on the left side of the X-axis.
2. Using a 5/32-inch Allen wrench, remove the appropriate inner hard stop from the X-axis. See [Figure 5-5](#).

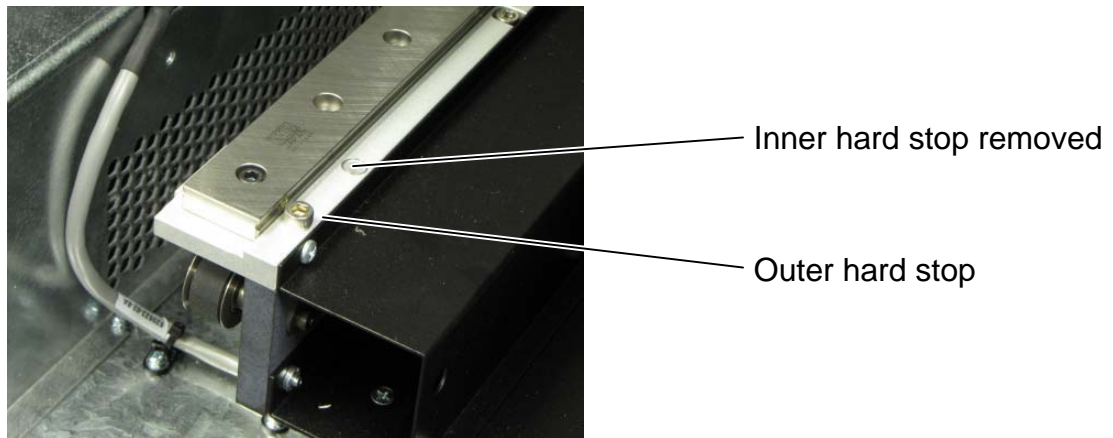

Figure 5-5 X-axis hard stop removed (left side shown)

5.3 Releasing the Carousel Locks in a XLS-85000 MEM

CAUTION

The carousel in the XLS-85000 MEM is locked into place for shipping. You must release the carousel locks before installing the MEM.

To release the carousel locks, follow these steps:

1. On the top of the MEM, locate the four socket-head cap screws, as shown in [Figure 5-6](#).

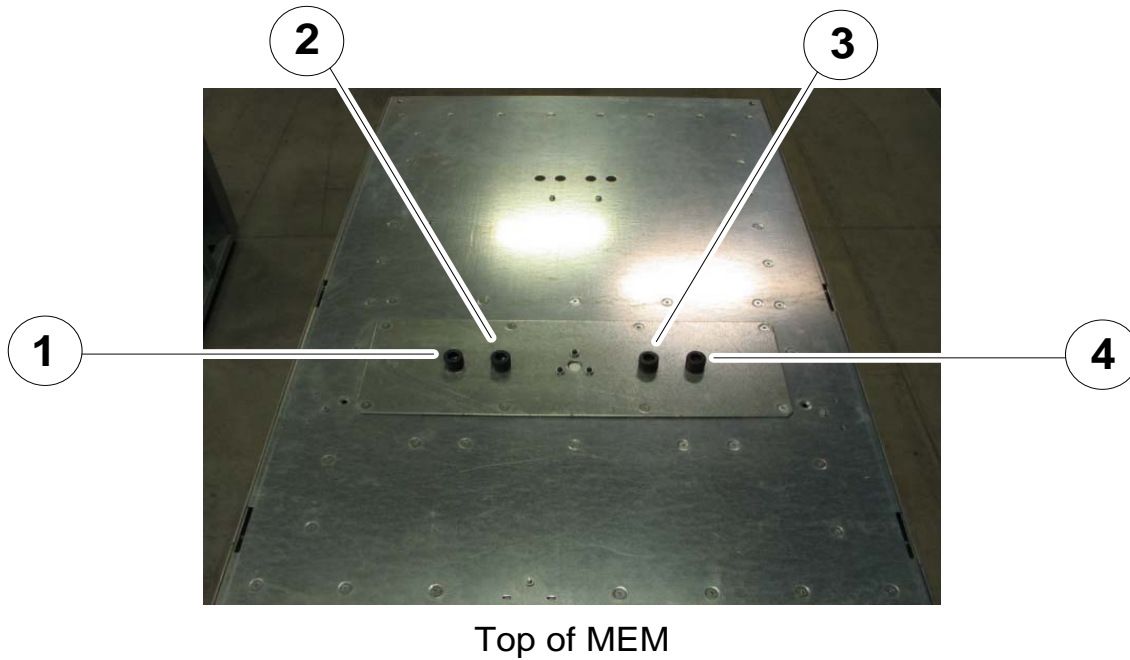

Figure 5-6 Location of the carousel lock screws on the top of the MEM

2. Use a 3/8-inch Allen wrench to remove screws 1 and 4 as shown in [Figure 5-6](#).
3. Gradually remove screws 2 and 3 as follows:
 - a. Loosen screw 2 a few turns.
 - b. Loosen screw 3 a few turns.
 - c. Repeat steps a and b until screws 2 and 3 can be removed from the top of the MEM.
4. Store the screws in the four holes in the top of the MEM. See [Figure 5-7 on page 5-6](#).



Top of MEM

Figure 5-7 Storing the screws in the top of the MEM

Important: Be sure to store the screws in the top of the MEM; they may be required later for service use.

5. Turn the carousel by hand to ensure that it rotates smoothly and without encountering any obstructions. The carousel will be hard to turn.

CAUTION

Do not use the edges of the cartridge slots to turn the carousel.

5.4 Connecting the Carousel Controller Cable

The carousel controller cable connects the system controller in the LRM to the carousel controller at the back of the MEM. This cable allows the LRM to provide power and control to the MEM.

To connect the carousel controller cable, follow these steps:

1. Using a #2 Phillips screwdriver, remove the eight screws that attach the lower panel to the back of the XLS-85000 MEM. Note that the two screws in the top, center of the panel are shorter than the other six. See [Figure 5-8](#).



Figure 5-8 Removing the MEM's lower back panel

2. Route the cable as follows:
 - Out the side of the LRM
 - Into the side of the MEM
 - Out the back of the MEM
3. Connect the cable to either of the two keyed connectors on the back of the MEM's carousel controller. See [Figure 5-9](#).



XLS-85000

Figure 5-9 Connecting the carousel controller cable to the carousel controller

4. Using a #2 Phillips screwdriver, replace the lower panel on the back of the MEM with the eight screws.

5.5 Attaching the LRM to the MEM

To attach the LRM to the MEM, follow these steps:

1. On the right side of the MEM, locate the two alignment holes at the top and bottom.
2. Insert the narrow end of a bullet-nose alignment pin into each hole. See [Figure 5-10](#).

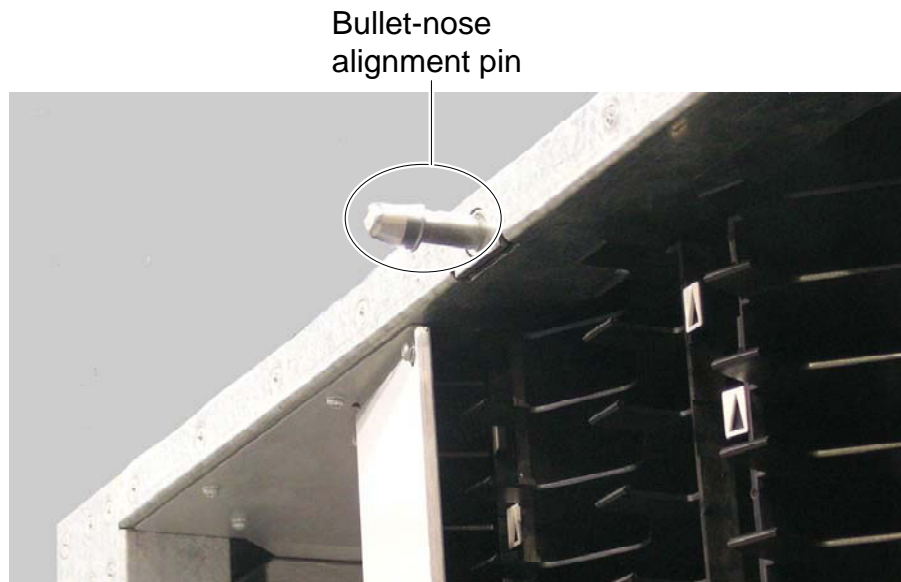

Figure 5-10 Inserting an alignment pin into the MEM (upper hole shown)

3. Confirm that the pins on the MEM align with the holes on the LRM.

Important: If the pins do not align with the holes, adjust the leveling feet on the MEM (see [Section 5.6 on page 5-9](#)).

4. Push the MEM against the LRM and guide the bullet-nose ends of the alignment pins into the corresponding holes on the LRM.
5. Locate the three holes on the back of the LRM frame that are used to secure the LRM to the MEM.
6. Open the doors of the MEM and the LRM to access the three holes in the front.

7. The direction of the bolts is as follows:
 - When the MEM is to the left of the LRM (as viewed from the front):
 - All six bolts go from the LRM to the MEM
8. From the MEM accessory kit, obtain six 5/16 x 1/2-inch socket head screws and washers.
9. Insert the screws through their washers and into the holes.
10. Tighten the screws with a 1/4-inch Allen wrench.

Important: If the holes on the MEM do not align with the holes on the LRM, adjust the leveling feet on the MEM (see [Section 5.6](#)).

5.6 Lowering the Leveling Feet

To lower the leveling feet on the MEM, follow these steps:

1. Locate the four leveling feet on the MEM. See [Figure 5-11](#)

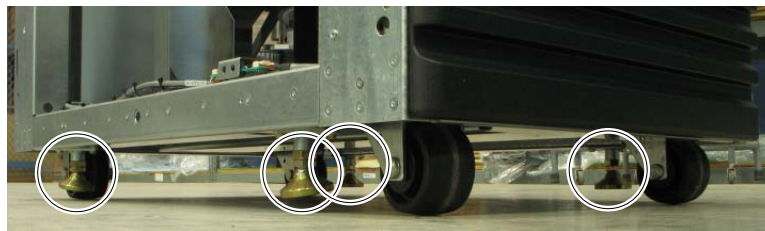

XLS-85000

Figure 5-11 Location of the four leveling feet on the MEM

- Using a 3/4-inch open-end wrench, turn one of the jam nuts to loosen the leveling foot. See [Figure 5-12](#).

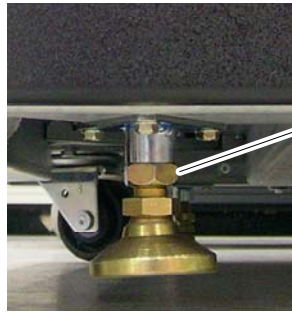

Turn jam nut to
loosen leveling foot

Figure 5-12 Loosening a leveling foot

- Using the same wrench, extend the leveling foot until it touches the floor. Then, turn the nut two more complete turns. See [Figure 5-13](#).

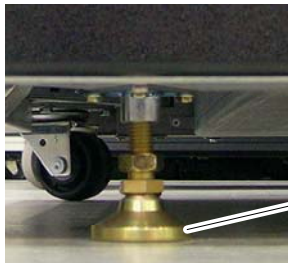

- Lower the foot to the floor.
- Turn the nut 2 more turns.

Figure 5-13 Extending a leveling foot

- Repeat steps 2 and 3 to extend the three other leveling feet.
- Check the alignment by placing a precision level on top of the LRM and MEM.

Important: Depending on the floor conditions, you may need to adjust the leveling feet on the LRM or the MEM up or down. Keep checking the alignment until both the LRM and the MEM are at an even level.

6. Once the equipment is level, turn the four jam nuts on the MEM and the four jam nuts on the LRM clockwise until they push up against the frame. See [Figure 5-14](#).

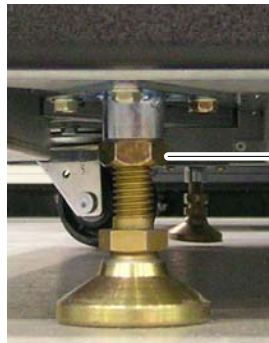

Turn jam nut until it pushes against the frame

Figure 5-14 Tightening a leveling foot

5.7 Installing the Side Panel on the MEM

To install the side panel on the MEM, follow these steps:

1. Holding the side panel with both hands, place the panel next to the MEM and carefully lower it until the hooks on the panel engage with the corresponding slots on the MEM's frame.
2. Insert the two screws in the holes at the bottom of the panel. See [Figure 5-15](#).



Figure 5-15 Installing the side panel on the MEM

3. Using a #2 Phillips screwdriver, tighten the screws.
4. After installing the MEM, install and connect the tape drives, then power on the XLS as described in [Chapter 9, “Applying Power and Logging Into X-Link.”](#)

5. After powering on the XLS, log in and refer to the instructions in [Section 10.2, “Aligning the Gripper with a MEM,” on page 10-4](#) to align the gripper to the carousel slots and to update the hardware configuration.

6 Installing an Expansion Pod

This chapter provide instructions for attaching an expansion pod to an XLS-810160/810240. Each expansion pod provides storage for an additional 116 cartridges.

Important: For instructions for attaching an expansion pod after the XLS-810160/810240 has been powered on and configured, refer to the *XLS Library Technical Service Manual*.

Procedure overview: [Table 6-1](#) provides an overview of installing an expansion pod.

Step	Task	Refer to...
1	Remove the left side panel from the XLS-810160/810240	Section 6.1 on page 6-2
2	Install the expansion pod mounting hardware	Section 6.2 on page 6-3
3	Remove the X-axis hard stop	Section 6.3 on page 6-7
4	Attach the expansion pod to the XLS-810160/810240	Section 6.4 on page 6-8
5	Install the rear side panel	Section 6.5 on page 6-11

Table 6-1 Overview of installing an expansion pod

Required tools: Make sure you have the following:

- #2 Phillips screwdriver
- T20 Torx driver
- 5/32-inch Allen wrench
- 5/16-inch Allen wrench (included in the accessory box)
- Wire cutters or scissors

Items shipped with the expansion pods:

- Top hinge mount
- Bottom hinge mount
- Rear side panel
- Front L brace
- Alignment pins (2)
- Plastic shims (4)
- 6-32 x 5/16 Torx screws (5)
- 6-32 x 3/4 flat-head screws (6)
- 10-32 x 1-1/4 socket-head screws (3)
- **Left expansion pod:**
 - 3/8-16 x 1/2 socket-head screws (3)
 - 3/8 flat washers (3)

6.1 Removing the Left Side Panel from the XLS-810160/810240

To remove the left side panels from the XLS-810160/810240, follow these steps:

1. On the left side of the LRM, locate the two Phillips screws at the base of the side panel.
2. Using a #2 Phillips screwdriver, remove the two screws. See [Figure 6-1](#).

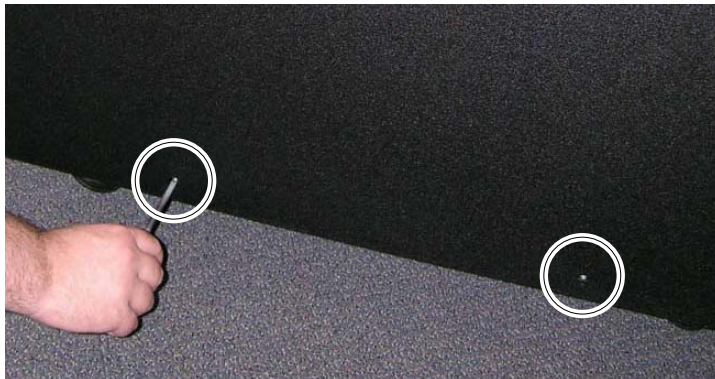

Figure 6-1 Removing the screws from the side panel

3. Carefully slide the panel up until you can lift the hooks out of the corresponding slots on the frame. See [Figure 6-2](#).



Figure 6-2 Removing a side panel

4. Save the side panel and screws for future use if the expansion pod is removed from the LRM.

6.2 Installing the Expansion Pod Mounting Hardware

To install the mounting hardware for the expansion pod, follow these steps:

1. On the exposed side of the LRM, locate the expansion-pod controller cable. See [Figure 6-3](#).



Figure 6-3 Expansion-pod controller cable on the side of the LRM

2. Cut the cable ties holding the cable to the frame.
3. In the accessory kit for the expansion pod, locate the top and bottom hinge mounts, the two alignment pins, and the six flat-head screws.
4. Insert the narrow ends of the alignment pins into the corresponding holes on the top and bottom hinge mounts. See [Figure 6-4](#).



Figure 6-4 Inserting an alignment pin into a hinge mount

5. Insert the bullet-nose end of the alignment pin into the hole at the top of the LRM.

6. Secure the top hinge mount using three flat-head screws. Ensure that the hinge pins point upward. See [Figure 6-5](#).

Make sure hinge pins
point up



Figure 6-5 Attaching the top hinge mount

7. Hold the bottom hinge mount against the XLS-810160/810240 and route the expansion-pod controller cable through the channel on the bottom hinge mount. See [Figure 6-6](#).



Figure 6-6 Routing the expansion-pod controller cable through the bottom hinge mount

8. Attach the bottom hinge mount to the LRM using one alignment pin and three flat-head screws.
9. Install a plastic shim on the four hinge pins. See [Figure 6-7](#).



Figure 6-7 Installing a plastic shim on a hinge pin

10. Attach the front L brace to the LRM as shown in [Figure 6-8](#). Note that:
 - Use three 3/8 x 1/2 socket-head screws and three 3/8-inch flat washers
 - Install the screws from the inside of the XLS. That is, insert them into the XLS frame, then into the pem nuts on the brace.



Figure 6-8 Front L brace on the left side of the LRM

6.3 Removing the X-Axis Hard Stop

When shipped, the X-axis (horizontal axis) on the handler includes two inner and two outer “hard stops,” which are simply #10 cap screws located at each end of the X-axis. See [Figure 6-9](#).

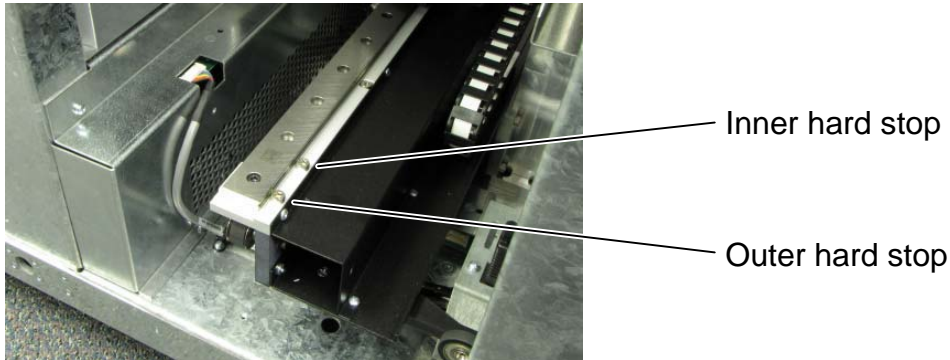

Figure 6-9 Outer and inner hard stops on the handler’s X-axis (left side shown)

When the inner hard stops are installed, the handler is prevented from traveling too far to the left and right. When an inner hard stop is removed, the handler can reach into an attached expansion pod.

You need to remove the inner hard stop on the left side where you will install the expansion pod.

CAUTION

To avoid damage to the equipment, never remove the two outer stops.

To remove an inner hard stop, follow these steps:

1. You will install a expansion pod on the left side of the LRM, so locate the inner hard stop on the left side of the X-axis.

2. Using a 5/32-inch Allen wrench, remove the appropriate inner hard stop from the X-axis. See [Figure 6-10](#).

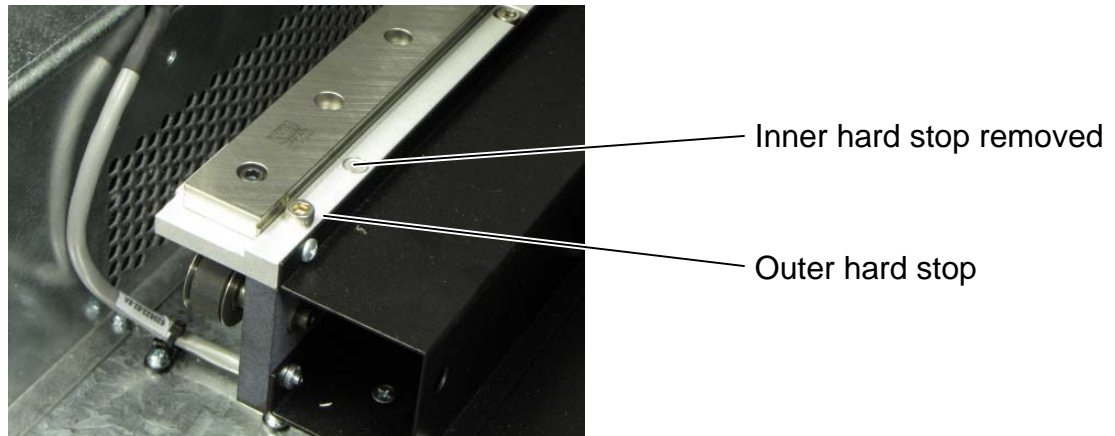

Figure 6-10 Removing the X-axis hard stop (left side shown)

6.4 Attaching the Expansion Pod to the XLS-810160/810240

To attach the expansion pod to the LRM, follow these steps:

1. If necessary, lower the leveling feet on the LRM. See [Section 4.1 on page 4-1](#) for instructions.

2. Lift the pod up and insert the four hinge pins on the LRM into the corresponding holes on the pod. See [Figure 6-11](#).



Figure 6-11 Attaching an expansion pod

3. Connect the expansion-pod controller cable to the keyed connector on the pod controller card. See [Figure 6-12](#).



Figure 6-12 Connecting the expansion-pod controller cable to the pod controller

4. Push the expansion pod against the LRM and guide the top and bottom alignment pins on the LRM into the corresponding holes on the expansion pod. See [Figure 6-13](#).

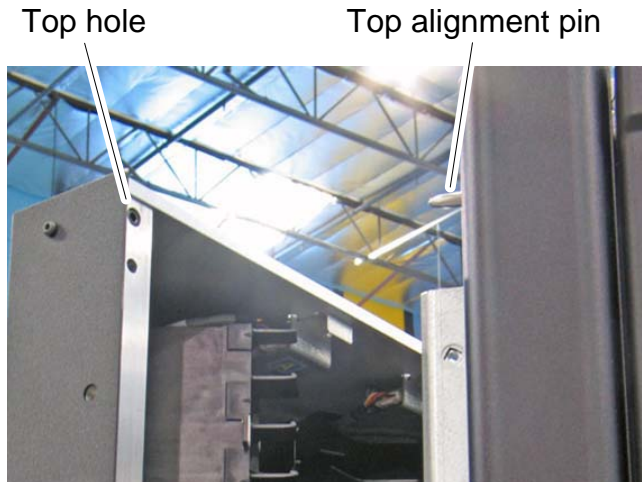

Figure 6-13 Aligning the expansion pod with the LRM

5. Insert three 10-32 x 1-1/4 socket-head screws through the three holes on the outside of the expansion pod. See [Figure 6-14](#) for the location of the top-most hole.



Figure 6-14 Location of top-most hole for securing an expansion pod to the XLS-810160/810240

6. Using a 5/32-inch Allen wrench, tighten the screws to secure the expansion pod to the LRM.

6.5 Installing the Rear Side Panel

To install the rear side panel on the MEM, follow these steps:

1. Holding the side panel with both hands, place the panel next to the MEM and secure it with the five Torx screws. See [Figure 6-15](#) for the location of the three top screws.



Figure 6-15 Installing the side panel on the expansion pod

2. Insert one screw in the hole at the bottom of the panel. Using a #2 Phillips screwdriver, tighten the screw.
3. After installing the expansion pod, power on the XLS as described in [Chapter 9, “Applying Power and Logging Into X-Link.”](#)
4. Then, log in and refer to the instructions in [Section 10.2, “Aligning the Gripper with a MEM,” on page 10-4](#) to align the gripper to the extra slots and to update the hardware configuration.

Notes:

7

Installing the Tape Drive Assemblies

This chapter provides instructions for installing the tape drive assemblies in the XLS. The library can accommodate up to 10 tape drives, which are installed in individual drive carriers at the factory.

CAUTION

To avoid damaging the equipment and voiding your warranty, do not attempt to remove the tape drives from the drive carriers. The tape drives used in the XLS must be installed into drive carriers at the factory.

When it is shipped, the XLS includes one to five drive bays (see [Figure 7-1](#)). To install a tape drive, you simply slide the assembly into a drive bay and secure it with four screws.



Figure 7-1 Drive bay with two Fibre Channel tape drive assemblies (view from the back)



LTO3 LVD/SE
P/N 520903-01-4

LTO4 LVD/SE
P/N 520903-03-0

Figure 7-2 Sample of SCSI LTO3 and LTO4 tape drive assemblies

Currently there are two types of SCSI tape drive assemblies available. See [Figure 7-2 on page 7-1](#). LTO3 models, which require termination at both ends of the SCSI bus and LTO4 models, which are self terminating in the tape drive assembly itself.

7.1 Before You Begin

Before installing the tape drive assemblies, create a map of where each tape drive should go. See [Figure 7-10 on page 7-12](#) for a worksheet you can use to help plan tape drive installation.

7.1.1 Guidelines for Tape Drive Installation

When determining where to install the tape drives, consider the following rules and guidelines:

- **Drive filler assemblies.** For safety and UL compliance, a drive filler assembly (see [Figure 7-3](#)) must be installed in any unused tape drive slot. If there are empty tape drive slots, the handler will be prevented from moving when power is applied to the library.

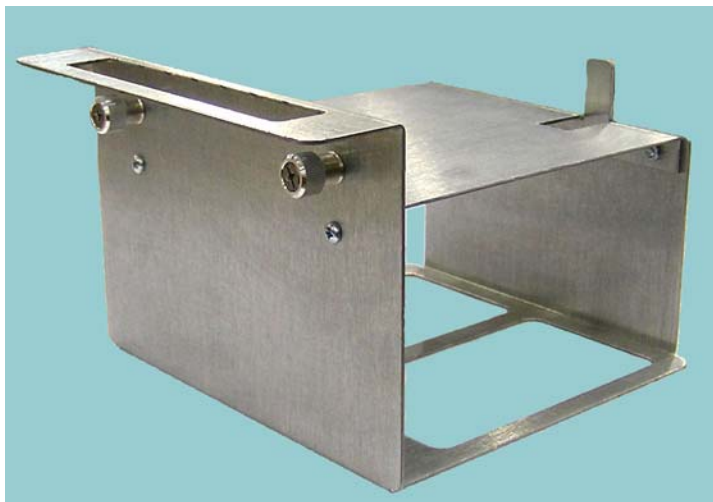

Figure 7-3 Drive filler assembly

- **Logical libraries.** To simplify logical library definition and maintenance, use side-by-side locations within a drive bay when installing the tape drives for a logical library. As required, you can install drive filler assemblies to reserve specific tape drive locations for future growth. Or, you can install the tape drives for more than one logical library in a single bay.
- **Tape drive interface.** Although you can install SCSI and Fibre Channel tape drives in a single bay, you may want to use the lowermost bays for SCSI tape drives. This will help minimize cable length issues if you connect the HBA and

the tape drive to the same SCSI bus. In addition, use side-by-side locations within a drive bay if you plan to put more than one tape drive on the SCSI bus.

Important: Because the transfer rate for Ultra 160 SCSI is limited to 160 MB/second, placing two high-speed tape drives on a single bus may prevent both drives from streaming data.

7.1.2 Example Cabling Diagrams

This section provides examples for installing the tape drives and connecting them to one or more SCSI buses or Fibre Channel networks. You may find it helpful to create similar cabling diagrams before installing the tape drives and connecting the cables.

Important: The example logical libraries shown use Fibre Channel tape drives with Fibre Channel HBAs or SCSI tape drives with SCSI HBAs. However, the communication protocols used by the tape drives and the medium changer do not need to be the same. A logical library can contain Fibre Channel tape drives and a SCSI HBA or a SCSI tape drive and Fibre Channel HBA.

Example 1: LTO3 SCSI Connections

[Figure 7-4 on page 7-4](#) shows the cabling scheme for two logical libraries, with each logical library containing a single LTO3 SCSI tape drive. The logical libraries are controlled as follows:

- Logical Library 1 contains one LTO3 SCSI tape drive. The software application in the host computer communicates with the tape drive and the medium changer over a single SCSI bus. One end of the bus is terminated by the upper port of HBA A in the system controller (which provides active termination); the other end is terminated by the host computer.

- Logical Library 2 also contains one LTO3 SCSI tape drive in a drive bay shared with Logical Library 1. The software application communicates with the tape drive and the medium changer over a single SCSI bus, terminated by the lower port of HBA A and by the host computer.

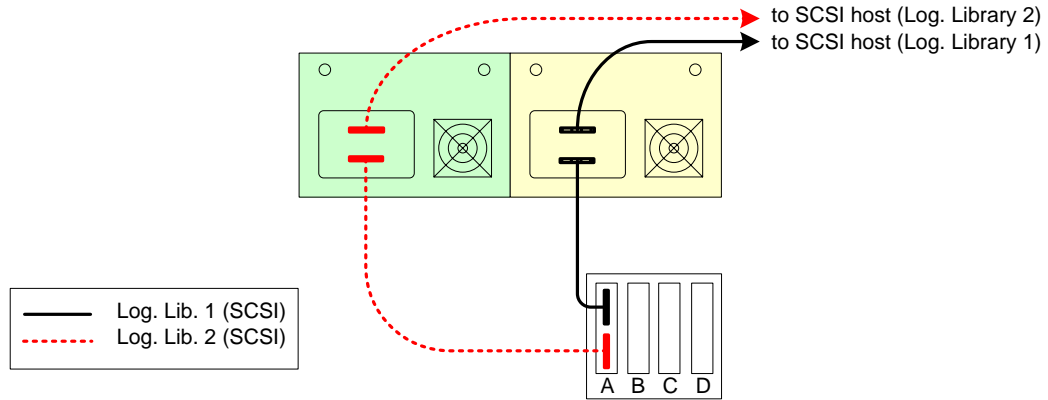

Figure 7-4 Example 1: LTO3 SCSI cabling diagram (view from the back of the LRM)

Example 2: LTO4 SCSI Connections

[Figure 7-4](#) shows the cabling scheme for two logical libraries, with each logical library containing a single LTO4 SCSI tape drive. The logical libraries are controlled as follows:

- Logical Library 1 contains one LTO4 SCSI tape drive. The software application in the host computer communicates with the tape drive and the medium changer over two separate SCSI buses. The LTO4 SCSI tape drive carrier is self-terminating and the other end is terminated by the host computer. The upper port of HBA A in the system controller (which provides active termination) and the other end is terminated by the host computer.

- Logical Library 2 also contains one LTO4 SCSI tape drive in a drive bay shared with Logical Library 1. The software application communicates with the tape drive and the medium changer over two separate SCSI buses. The LTO4 SCSI tape drive carrier is self terminating and the other end is terminated by the host computer. The lower port of HBA A in the system controller (which provides active termination) and the other end is terminated by the host computer.

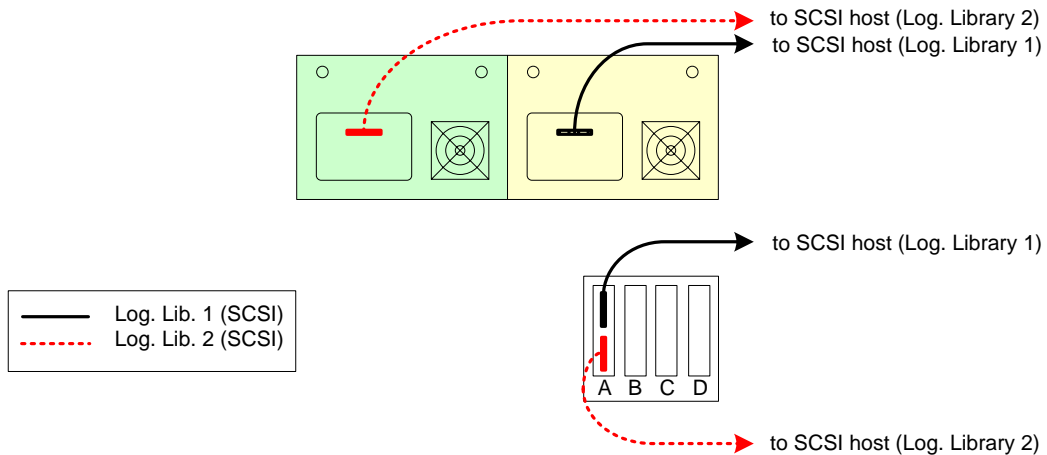

Figure 7-5 Example 2: LTO4 SCSI cabling diagram (view from the back of the LRM)

Example 3: Fibre Channel Connections

[Figure 7-6](#) shows the cabling scheme for an example Fibre Channel (FC) library that contains twelve tape drives and two Fibre Channel HBAs. The XLS has been partitioned into three logical libraries, as follows:

- Logical Library 1 contains two tape drives installed in two drive bays. The host software controls the medium changer using the upper port of HBA A.
- Logical Library 2 contains four tape drives in three drive bays. The host software controls the medium changer using the lower port of HBA A.
- Logical Library 3 contains three tape drives in two drive bays. The host software controls the medium changer using the upper port of HBA B.

The tape drives are connected to a Fibre Channel switch installed in the equipment rack. The three ports on the HBAs are also connected to this switch. The software application communicates with the medium changer and tape drives across a switched fabric.

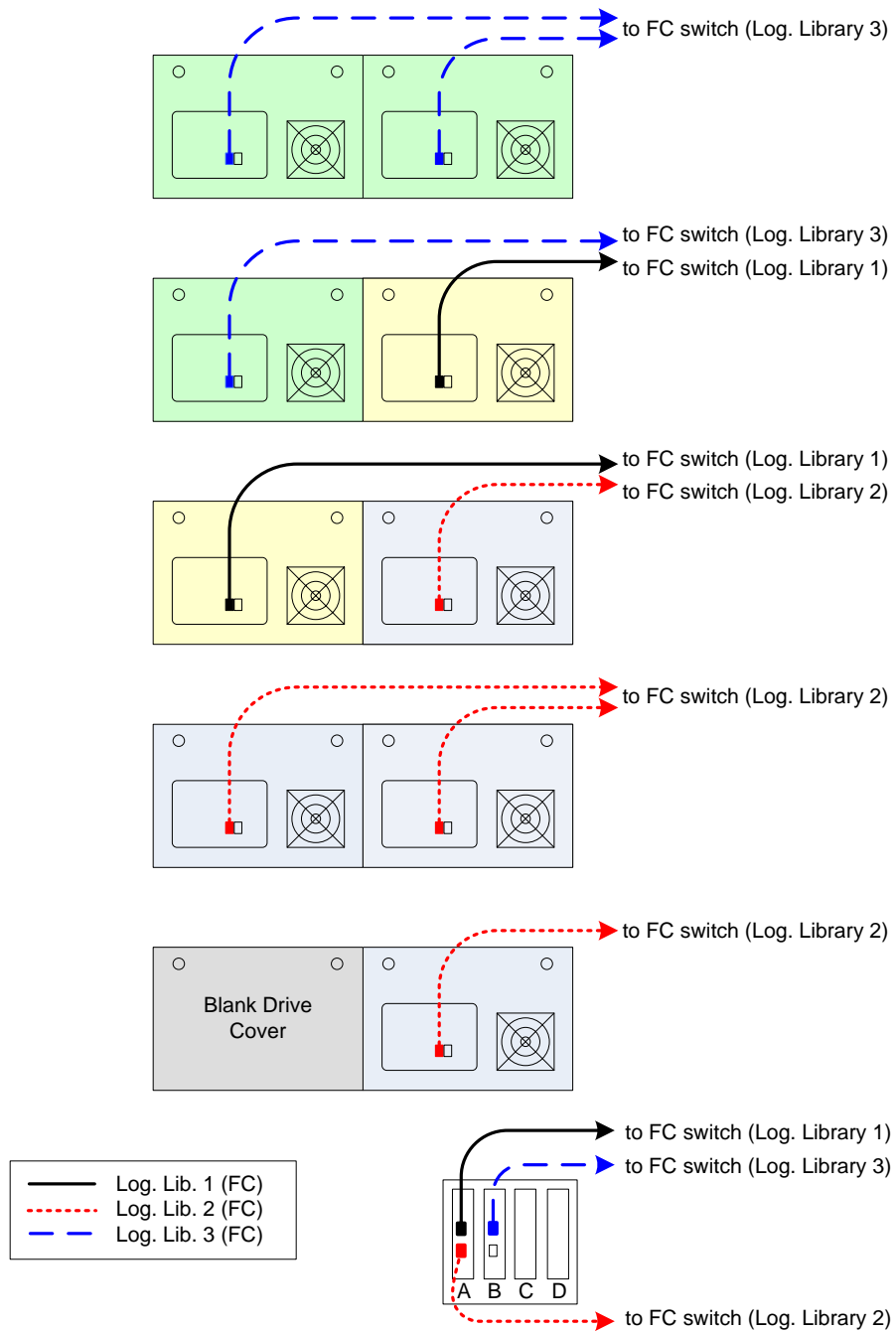

Figure 7-6 Example 3: Fibre Channel cabling diagram (view from the back of the LRM)

Example 4: Mixed SCSI and Fibre Channel Connections

[Figure 7-7 on page 7-8](#) shows the cabling scheme for an example library that contains ten tape drives and two HBAs. The XLS has been partitioned into four logical libraries, as follows:

- Logical Library 1 contains one LTO3 SCSI tape drive. The host computer communicates with the tape drive and the medium changer over a single SCSI bus, which is terminated by the upper port of HBA A and by the host computer.
- Logical Library 2 contains one LTO4 SCSI tape drive. The host computer communicates with the tape drive and the medium changer over two separate SCSI buses. The LTO4 SCSI tape drive carrier is self terminating and the other end is terminated by the host computer. The lower port of HBA A in the system controller (which provides active termination) and the other end is terminated by the host computer. The unused drive slots contain drive filler assemblies.
- Logical Library 3 contains four Fibre Channel tape drives in a single drive bay. The host computer controls the medium changer using the upper port of HBA B. The tape drives and the HBA port are cabled to a Fibre Channel switch installed in the equipment rack.
- Logical Library 4 contains four Fibre Channel tape drives in a single drive bay. The host computer controls the medium changer using the lower port of HBA B. The tape drives and the HBA port are cabled to a Fibre Channel switch installed in the equipment rack.

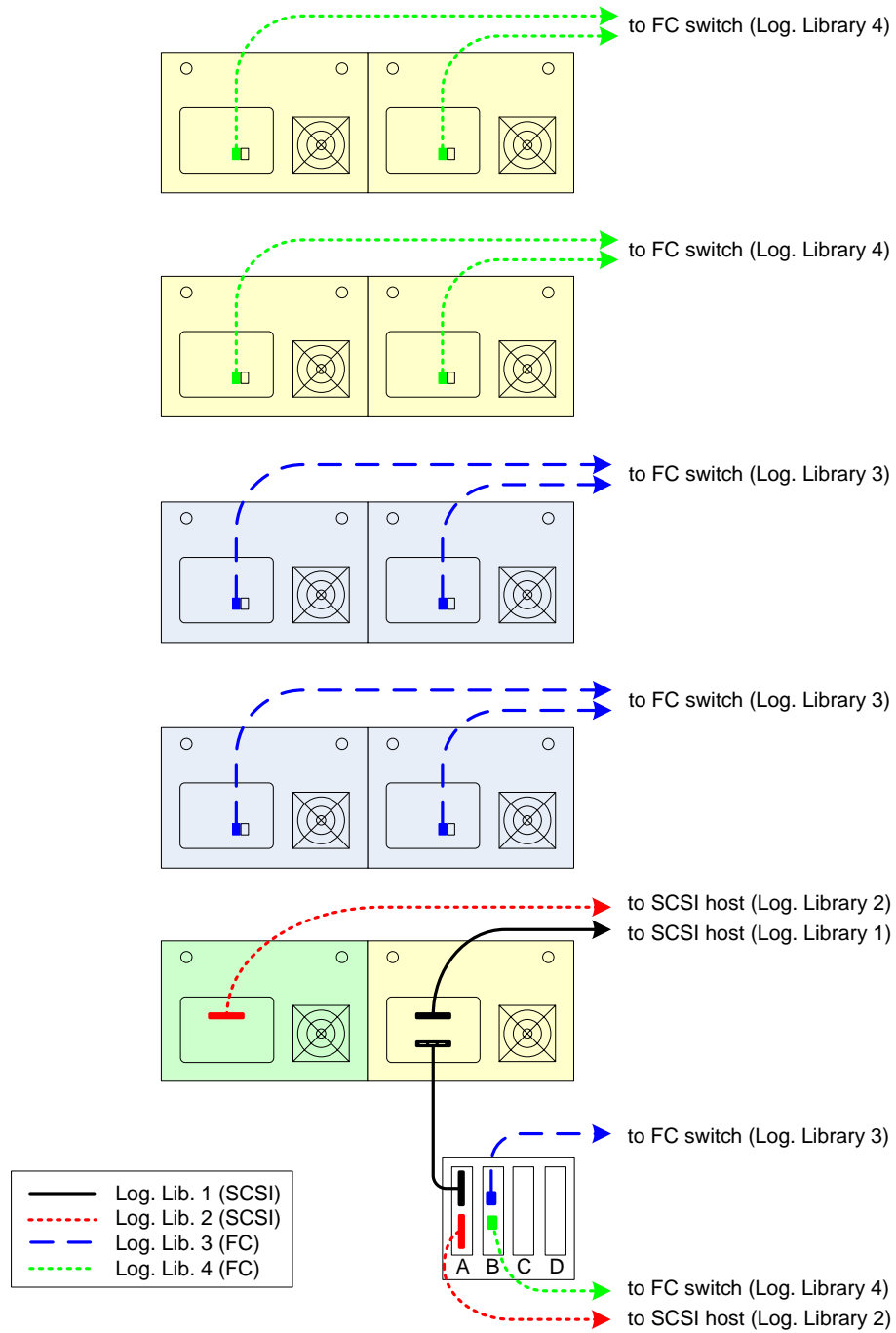

Figure 7-7 Example 4: Cabling diagram for library containing SCSI and Fibre Channel tape drives (view from the back of the LRM)

Example 5: Logical Library with Multiple Hosts

[Figure 7-8](#) shows an example logical library connected to four host computers.

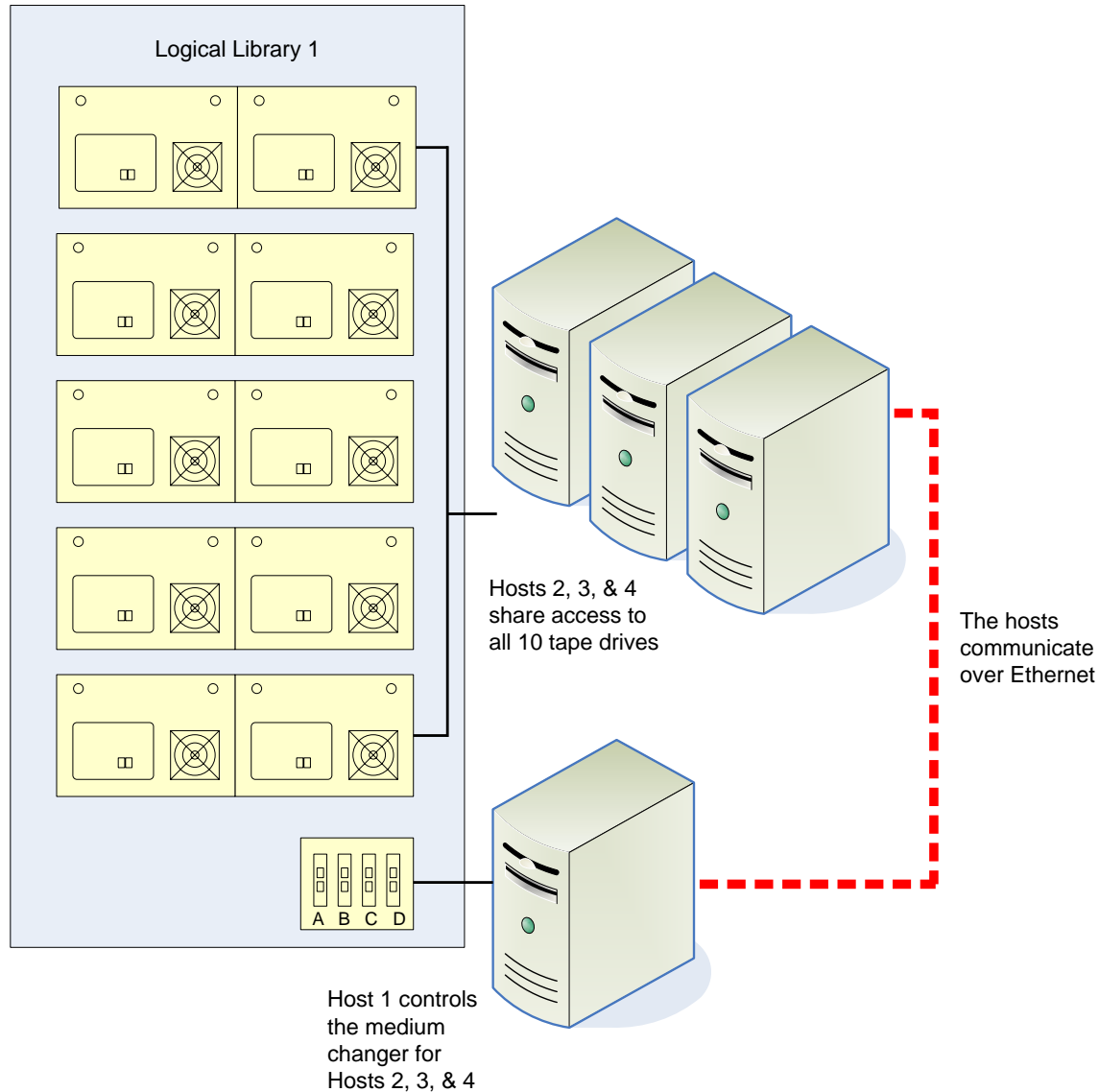

Figure 7-8 Example 5: Logical library with multiple hosts (view from the back of the LRM)

In the example:

- Host 1 is connected to one of the HBA ports in the system controller, and it controls the medium changer interface for the logical library.
- Hosts 2, 3, and 4 share access to the 10 tape drives but are not connected to the medium changer interface.

- Hosts 2, 3, and 4 are connected to Host 1 across an Ethernet network and communicate using specialized storage management software. The software enables Hosts 2, 3, and 4 to send requests to move media to Host 1. Host 1, in turn, manages and prioritizes the requests, issues the appropriate commands to the medium changer, and returns status to the other hosts.

7.1.3 Recording Tape Drive Locations

As described in [Section 11.2, “Creating a New Logical Library,” on page 11-3](#), you must specify a physical address (bay and column) for each tape drive when completing the Create Logical Library wizard. For this reason, you should record the locations of all tape drives and drive filler assemblies. You may find it helpful to use the worksheet in [Figure 7-10 on page 7-12](#), which shows all 10 possible tape drive locations in an LRM.

Record the following information on the worksheet:

- **Drive type:** Enter the type of drive or **n/a** (for empty drive slots).
- **Interface:** Enter **SCSI**, **FC** (Fibre Channel), or **n/a** (for empty drive slots).
- **Serial No.:** Enter the serial number of the tape drive or **Empty slot**. As you complete the Create Logical Library wizard, you may find it helpful to compare the serial number you recorded to the number displayed by X-Link.
- **Logical Library:** Enter the name of the logical library that will own this tape drive or empty slot.

[Figure 7-9](#) shows an example of a completed tape drive installation worksheet. This library has been partitioned into four logical libraries with twelve tape drives, as follows:

- Logical Library 1 includes a single SCSI tape drive in bay position 1A.
- Logical Library 2 includes a single SCSI tape drive in bay position 2A.
- Logical Library 3 includes a single SCSI tape drive in bay positions 2B, 1C, 2C and an empty tape drive slot in bay position 1B.

- Logical Library 4 includes four Fibre Channel tape drives in bay positions 1D, 2D, 1E and 2E.

Bay position: 2E Drive type: LTO-3 Interface: FC Serial No: 1210075384 Log. Lib.: 4	Bay position: 1E Drive type: LTO-3 Interface: FC Serial No: 1210073482 Log. Lib.: 4
Bay position: 2D Drive type: LTO-3 Interface: FC Serial No: 1210074064 Log. Lib.: 4	Bay position: 1D Drive type: LTO-3 Interface: FC Serial No: 1210075343 Log. Lib.: 4
Bay position: 2C Drive type: LTO-3 Interface: FC Serial No: 1210075231 Log. Lib.: 3	Bay position: 1C Drive type: LTO-3 Interface: FC Serial No: 1210075976 Log. Lib.: 3
Bay position: 2B Drive type: LTO-3 Interface: FC Serial No: 1210079041 Log. Lib.: 3	Bay position: 1B Drive type: n/a Interface: n/a Serial No: Empty Slot Log. Lib.: reserved for 3
Bay position: 2A Drive type: LTO-3 Interface: SCSI Serial No: 1210072380 Log. Lib.: 2	Bay position: 1A Drive type: LTO-3 Interface: SCSI Serial No: 1210071007 Log. Lib.: 1

Figure 7-9 Completed tape drive installation worksheet

Bay position: 2E Drive type: _____ Interface: _____ Serial No: _____ Log. Lib.: _____	Bay position: 1E Drive type: _____ Interface: _____ Serial No: _____ Log. Lib.: _____
Bay position: 2D Drive type: _____ Interface: _____ Serial No: _____ Log. Lib.: _____	Bay position: 1D Drive type: _____ Interface: _____ Serial No: _____ Log. Lib.: _____
Bay position: 2C Drive type: _____ Interface: _____ Serial No: _____ Log. Lib.: _____	Bay position: 1C Drive type: _____ Interface: _____ Serial No: _____ Log. Lib.: _____
Bay position: 2B Drive type: _____ Interface: _____ Serial No: _____ Log. Lib.: _____	Bay position: 1B Drive type: _____ Interface: _____ Serial No: _____ Log. Lib.: _____
Bay position: 2A Drive type: _____ Interface: _____ Serial No: _____ Log. Lib.: _____	Bay position: 1A Drive type: _____ Interface: _____ Serial No: _____ Log. Lib.: _____

Figure 7-10 Worksheet for tape drive installation (view from the back of the LRM)

7.2 Installing Tape Drive and Drive Filler Assemblies

Required tools and equipment: Make sure you have the following:

- Phillips screwdriver

Procedure: To install the tape drive and drive filler assemblies, follow these steps:

1. Refer to [“Before You Begin” on page 7-2](#) to determine where to install each tape drive or drive filler assembly.

- Using one hand to support the tape drive's weight at the front of the carrier, carefully slide the tape drive assembly into the appropriate slot in the drive bay, as shown in [Figure 7-11](#).



Figure 7-11 Inserting a tape drive assembly into a drive bay

- Push on the back of the tape drive to ensure that the connectors are fully seated and that the carrier's gasket has made a good seal against the drive bay.
- Using a Phillips screwdriver, turn the two captive screws clockwise until tight. See [Figure 7-12](#).

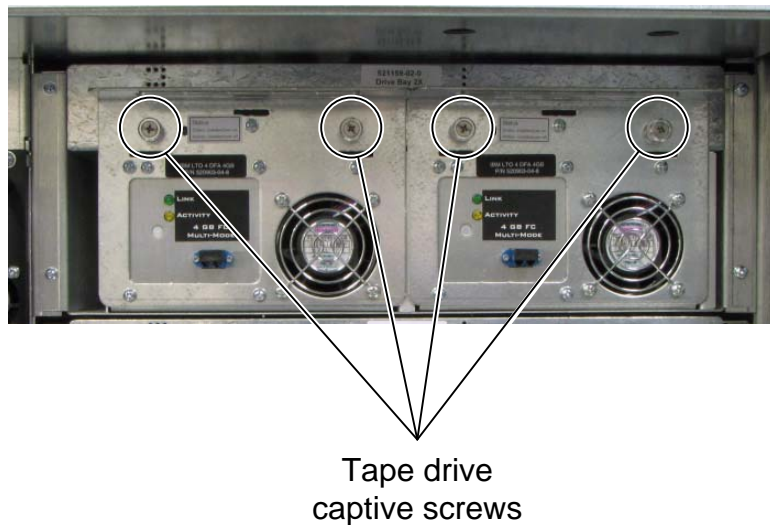

Figure 7-12 Tightening the tape drive assembly screws

- Repeat steps 2–4 to install all of the tape drive assemblies.

6. As required, repeat steps 2–4 to install drive filler assemblies (shown in [Figure 7-3 on page 7-2](#)) in any unused positions.

CAUTION

For safety and UL compliance, a drive filler assembly must be installed in any unused tape drive slot. If there are empty tape drive slots, the XLS handler will be prevented from moving when power is applied to the library.

8

Connecting the XLS

This chapter provides instructions for connecting the library and the tape drives to one or more SCSI buses or Fibre Channel networks. It also includes instructions for editing the target IDs for the HBAs and tape drives.

The instructions in this chapter assume that you have previous experience connecting and configuring SCSI buses or Fibre Channel networks. For examples of SCSI, Fibre Channel, and mixed configurations, see [Section 7.1.2 on page 7-3](#).

8.1 Before You Begin

- **For Fibre Channel installations**, obtain the appropriate number of Fibre Channel cables to connect each Fibre Channel tape drive and HBA to the Fibre Channel switch. The tape drives and the HBAs in the XLS both use multimode 62.5/125 fiber optic patch cables with duplex LC connectors.
- **For SCSI installations**, obtain the appropriate number of external Ultra 160 or better SCSI cables and terminators (if using LTO3 tape drives) to connect each SCSI tape drive and HBA to a SCSI bus. The tape drives use HD68 connectors, while the HBAs use VHDCI connectors.

Important: Do not use HVD or single-ended SCSI cables and terminators. You must use Ultra 160 or better SCSI cables and terminators.

8.2 Connecting the Cables

This section provides instructions for the following:

- Removing the EMI shield (see [Section 8.2.1 on page 8-2](#))
- Installing the cables and terminators (see [Section 8.2.2 on page 8-2](#))
- Replacing the EMI shield (see [Section 8.2.3 on page 8-6](#))

8.2.1 Removing the EMI Shield

The EMI shield, shown in [Figure 8-1](#), reduces potential electromagnetic interference from the connectors on the library and must be removed before you can access the HBA ports to attach the cables.

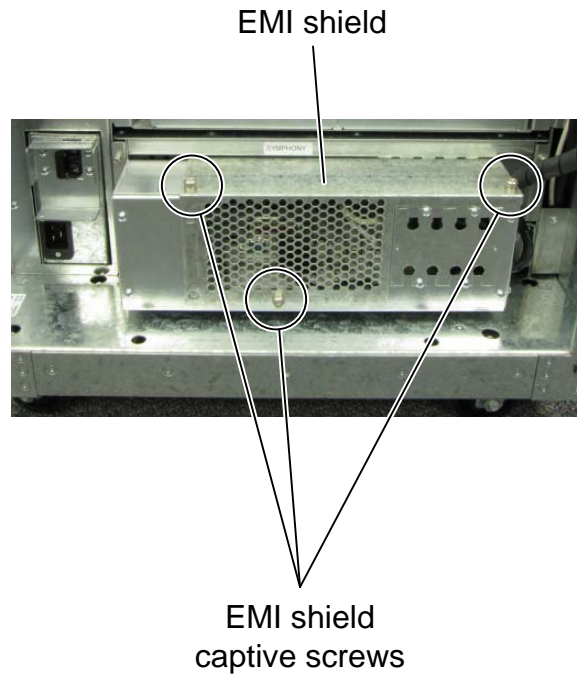

Figure 8-1 Location of the EMI shield

To remove the EMI shield, follow these steps:

1. Loosen the three captive screws that secure the EMI shield to the system controller.
2. Set the shield aside.

8.2.2 Connecting the Cables

You can connect and control the medium changer and the tape drives in a number of ways, using parallel SCSI buses, Fibre Channel networks, or a combination of both. The communication protocol is determined by the type of host bus adapter card (HBA) installed in the system controller. The XLS supports up to four dual-port SCSI or Fibre Channel HBAs.

Important: The HBAs control the XLS's medium changer interface only; they do not control or communicate with the tape drives.

If the XLS has multiple SCSI and Fibre Channel HBAs installed, the SCSI HBAs must be installed in the left slot(s) first as viewed from the rear of the library (next to the CAN bus controller card). The Fibre Channel HBAs must be installed in the slots to the right of the installed SCSI HBAs. This is due to the process in which the system controller enumerates the SCSI HBAs first then the Fibre Channel HBAs. See [Figure 8-2](#) for examples.

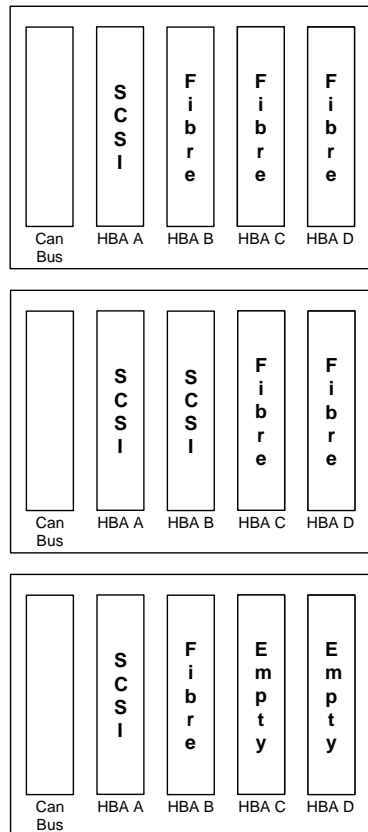

Figure 8-2 Example of multiple SCSI and Fibre Channel HBA connections

Connecting SCSI Cables and Terminators

To connect LTO3 tape drive SCSI cables and terminators, follow these steps:

1. Connect one or more tape drives, as follows:
 - a. Connect an external SCSI cable to a tape drive.

- b. As required, daisy chain adjacent tape drives by connecting them with a VHDCI drive-to-drive SCSI cable.

Important: Because the transfer rate for Ultra 160 SCSI is limited to 160 MB/second, placing two high-speed tape drives on a single bus may prevent both drives from streaming data.

- c. If the tape drive will terminate the SCSI bus, install an active Ultra 160 SCSI terminator on the unused SCSI connector.

To connect LTO4 tape drive SCSI cables, follow these steps:

1. Connect one or more tape drives, as follows:
 - a. Connect an external SCSI cable to a tape drive.

Note: The LTO4 SCSI tape drives provide active termination.

To connect the HBA SCSI cables, follow these steps:

1. Connect the HBA, as follows:
 - a. Route an external SCSI cable through the appropriate slot on the back of the system controller.
 - b. Attach the cable to a port on a SCSI HBA. If multiple SCSI and Fibre Channel HBAs are installed the SCSI HBAs must be installed in the left slot(s) first, next to the CAN bus controller card, then followed by any Fibre Channel HBAs.

Important: Be sure to connect the cable to the HBA port you specified when creating the logical library (see [page 11-8](#)).

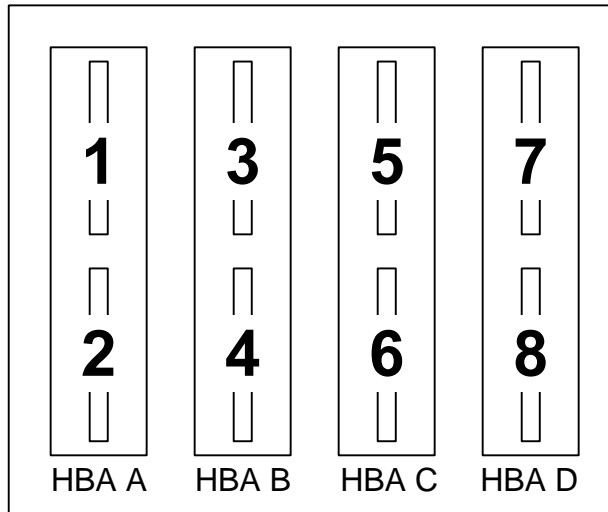

Figure 8-3 HBA port IDs

2. Connect the other ends of the SCSI cables to the SCSI bus. Ensure that the bus is correctly terminated.

Note: The SCSI HBAs provide active termination.

Connecting Fibre Channel Cables

To connect the Fibre Channel cables, follow these steps:

1. Connect one or more tape drives, as follows:
 - a. Use one hand to lift the safety covers on the Fibre Channel connectors. See [Figure 8-4](#).



Figure 8-4 Attaching the cable to a Fibre Channel tape drive

- b. Attach an optical cable to the Fibre Channel connectors on each tape drive.
2. Connect the HBA, as follows:
 - a. Route an optical cable through the appropriate slot on the back of the system controller.
 - b. Attach the cable to a port on a Fibre Channel HBA. If multiple SCSI and Fibre Channel HBAs are installed the SCSI HBAs must be installed in the left slot(s) first, next to the CAN bus controller card, then followed by any Fibre Channel HBAs.

Important: Be sure to connect the cable to the HBA port you specified when creating the logical library (see [page 11-8](#)).

3. Connect the other ends of the optical cables to the appropriate Fibre Channel hubs or switches.
4. As an option, the fibre channel cables attached to the tape drives may be attached to the three included cable routing brackets to route the cables downward. If brackets are required to route the cables upward, please contact Qualstar Technical Support and request part number 521301-04-4.
 - a. The brackets are designed to be installed one row below the tape drives on the left side of the drive bay. Using a Phillips screwdriver remove the two screws securing the the drive bay then place a bracket over the holes and secure it with the screws. Repeat for each bracket being installed. See [Figure 8-5](#).



Figure 8-5 Attaching the cable routing brackets

- a. Once the brackets are installed the fibre channel cables can be routed over them and secured using the removeable cable ties that were included with the brackets. [Figure 8-6](#).

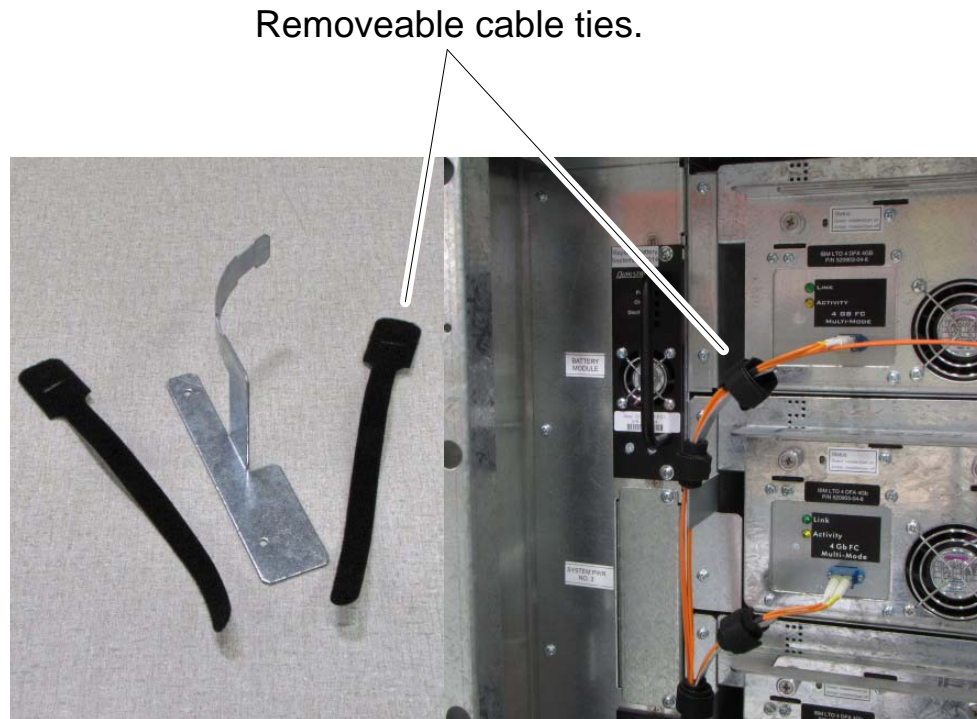

Figure 8-6 Securing the cables to the brackets

Important: Be careful to not damage the fibre channel cables while securing them to the cable routing brackets.

8.2.3 Replace the EMI Shield

After connecting the cables, replace the EMI shield and tighten the three captive screws.

Important: To avoid potential problems caused by electromagnetic interference, do not operate the library without the EMI shield in place.

Notes:

9 Applying Power and Logging Into X-Link

This chapter provides instructions and information for the following:

- Preparing to power on the library. See [Section 9.1](#)
- Connecting the library to power and performing the initial power on. See [Section 9.2 on page 9-3](#).
- Logging into X-Link. See [Section 9.3 on page 9-11](#).

9.1 Preparing to Power on the Library

Before powering on the library, check to make sure that all the hardware is installed correctly and that the library is ready. Follow these steps:

1. Make sure you have a power cord suitable for your input voltage and location (see the *XLS Library Product Specification*).
2. If you plan to connect the XLS to a UPS, obtain the UPS and UPS cable (see [Section 2.2 on page 2-4](#) for additional information).
3. Open the door on the library.
4. Confirm the following:
 - The shipment locks have been removed from the handler (see [Section 3.2.3 on page 3-7](#)).
 - No cartridges are protruding from the cartridge slots.
 - None of the tape drives contain a cartridge.
 - The handler does not contain a cartridge.
 - If a MEM is attached, the inner hard stop on the left side of the handler's X-axis has been removed, enabling the handler to reach into the MEM. See [Section 5.2 on page 5-3](#).

5. From the back of the library, check the following:
 - A tape drive or drive filler assembly is installed in every drive bay position.
 - An adequate number of power supplies are installed for the number of installed drive bays and an attached MEM. See the *XLS Library Product Specification*.
 - The input power source is adequate to support the number of installed drive bays and an attached MEM.

CAUTION

To avoid tripping the circuit breaker (either at the library or at the main circuit panel), ensure the input power is adequate to support the library's configuration.

6. If a MEM is attached to the LRM, confirm the following:
 - The carousel locks have been released. See [Section 5.3 on page 5-4](#).
 - The MEM cable from the LRM is securely connected to one of the two connectors on the MEM's carousel controller. See [Section 5.4 on page 5-6](#).
7. Close any open doors.
8. Confirm that the I/O ports are closed.

9.2 Connecting the Library to Power

In addition to the standard power connection provided on the library there is a redundant power input module available that allows the library to be connected to two independent power sources, providing a redundant power source in the event one of the power sources should fail. The unit powers the load from the first power input normally. The unit switches to the second power input if the first has failed.

To power on a library with the standard power connection, follow these steps:

1. Locate the power switch and power connector on the back of the library in the lower left, as shown in [Figure 9-1](#). Make sure the switch is off.

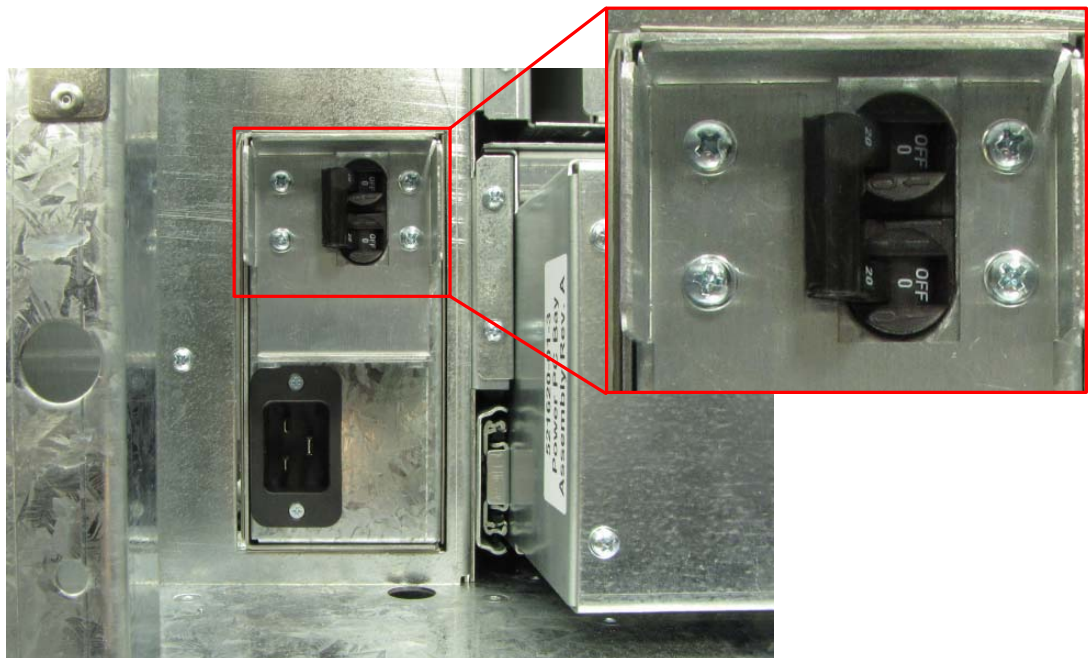

Figure 9-1 Location of the power switch and power connector

2. Connect the power cord to the power connector.
3. Plug the power cord into a wall outlet.
4. If you plan to use a UPS, follow these steps:
 - a. Connect the UPS cable (“UPS Communication Cable Smart Signaling”) to the serial port on the XLS.
 - b. Connect the UPS cable to the UPS.

- c. Connect the UPS's power cord to a wall outlet.

CAUTION

The battery module in the power/PC bay provides enough backup power to safely shut down the XLS if an unexpected power failure occurs. However, the battery module does not provide enough power to protect the tape drives. For this reason, Qualstar recommends that you connect the XLS to an external UPS. See [Section 2.2 on page 2-4](#) for the cabling and protocol requirements for the UPS.

5. Move the power switch to the on position. See [Figure 9-2](#).

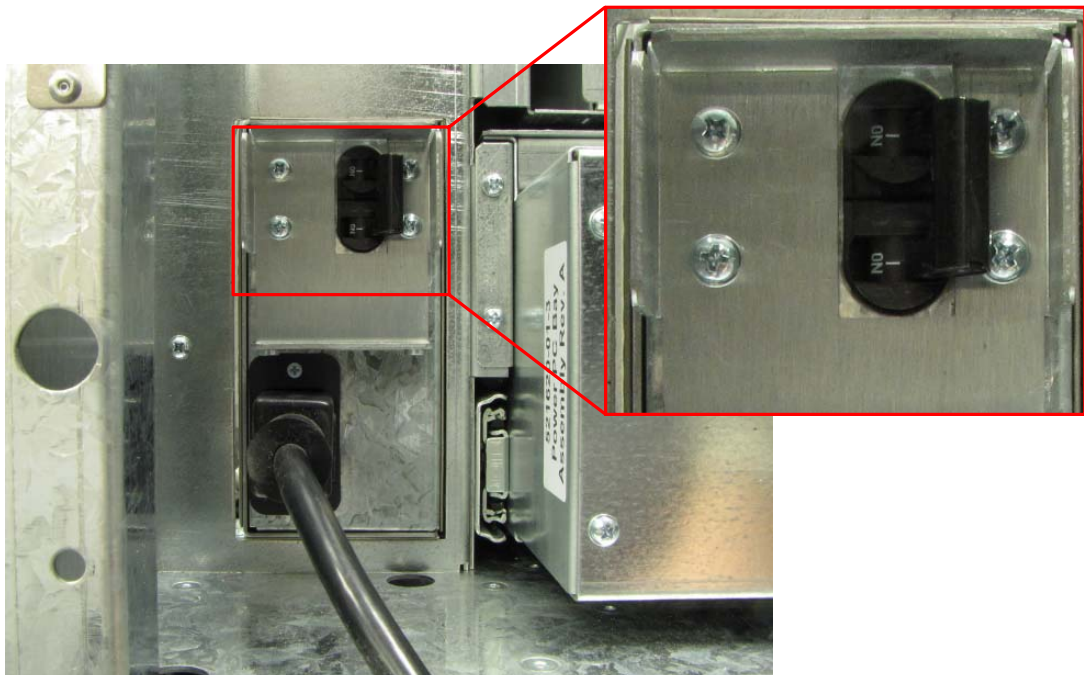

Figure 9-2 Power switch in on position

6. Wait for the power-on processes to complete.

To power on a library with the redundant power input module, follow these steps:

1. Locate the power switches and power connectors on the back of the library in the lower left, as shown in [Figure 9-3](#). Make sure both the switches are off.

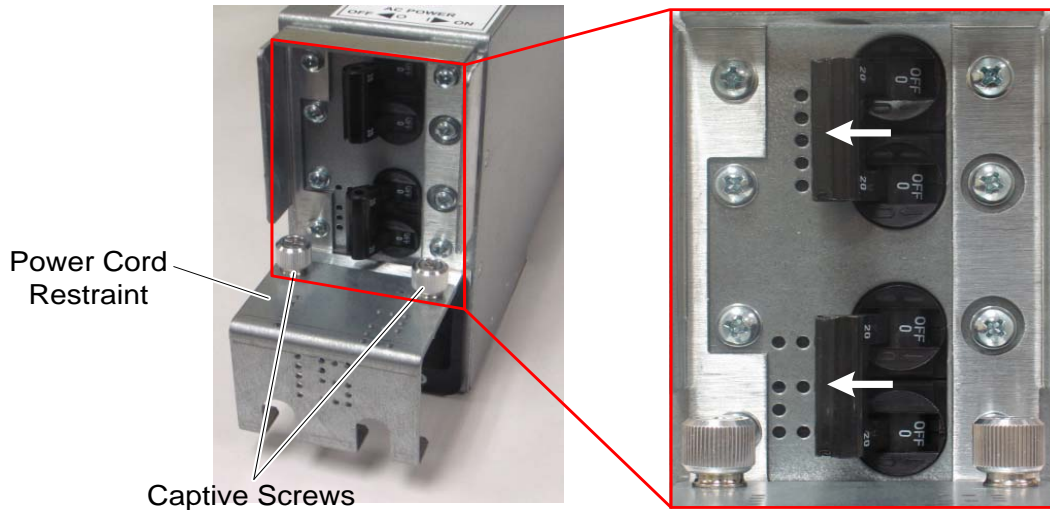

Figure 9-3 Location of the power switches and power connectors

2. If the power cord restraint is attached, loosen the captive screws and remove the restraint to access the power connectors.
3. Connect one of the power cords to power inlet 1 (on the left) and then connect the second cord to power inlet 2 (on the right). See [Figure 9-4](#).

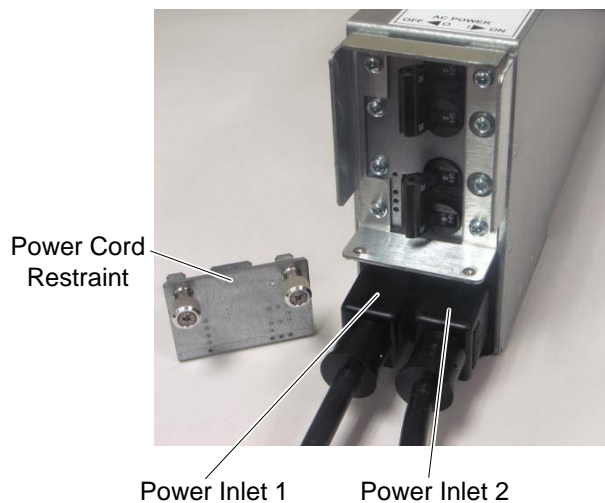

Figure 9-4 Attaching the power cords

4. Place the power cord restraint over the cords, as shown in [Figure 9-5](#) on [page 9-6](#) and tighten the captive screws securely.

5. Plug the power cord from power inlet 1 into the wall outlet that is the primary power source. The library will use this line as long as it is good. Connect the power cord from power inlet 2 into the wall outlet that is the backup power source. The library will only use this line if the power at inlet 1 has failed. If the library is running on line 2, it will switch back to line 1 four seconds after line 1 is restored.
6. Move both of the power switches to the on position. See [Figure 9-5](#).



Figure 9-5 Power switches in the on position

7. Wait for the power-on processes to complete.

During power-on:

- The status LEDs on the front panel of the LRM flash intermittently.
- The XLS scans the fiducial targets and cartridge slots in the I/O ports, then moves the handler to its home position.
- If a MEM is attached, the carousel rotates to its home position.
- The tape drives perform their own power-on processes. For information, refer to the documentation for the tape drives. When the tape drives are receiving power from the XLS, the Drive Status LEDs on the back of the tape drive assemblies are green.
- X-Link starts and the log-in page is displayed.

1. Once the power-up processes have completed, check the status of the Attention and Fault LEDs, as follows:
 - If the LEDs are off, the power-on processes completed without error and you can log in to X-Link, as described in [Section 9.3 on page 9-11](#).
 - If the LEDs are flashing, operator intervention is required. See [Section 9.2.1](#) for troubleshooting instructions.
2. If the error persists, contact Qualstar Technical Support for assistance.

9.2.1 Troubleshooting Problems with XLS Power-On Processes

If the Attention or Fault LED is flashing after you have powered on the XLS, follow these steps:

1. From the back of the library, look at each tape drive assembly and confirm that the Drive Status LED is green, indicating that the tape drive is installed and powered on. See [Figure 9-7 on page 9-9](#).
2. From the back of the library, look at each power supply and confirm that the PWR Good LED is green and the Fault LED is off. See [Figure 9-8 on page 9-10](#).
3. Rule out common explanations for a power-on failure. See [Table 9-1](#).

Cause of error...	Check this...
Tape drives or drive filler assemblies not installed in all positions	If the handler failed to move when the library was powered on, make sure that a tape drive or drive filler assembly is correctly installed in every tape drive position.
Handler unable to move	If the handler failed to move when you powered on the library, make sure that nothing is blocking the handler and that the shipment locks have been removed.
One or more doors open	If the Attention LED is flashing slowly, make sure the doors are securely closed.
One or more I/O port open	If the Attention LED is on solid, make sure the I/O ports are closed.
Light curtain blocked	If the Attention LED is flashing rapidly, one of the light curtain sensors may be blocked. Make sure that no cartridges are protruding from the slots.

Table 9-1 Initial troubleshooting steps for power-on error

Cause of error...	Check this...
Inadequate number of power supplies or power supplies not installed correctly	If the library failed to power up correctly, you may not have enough power supplies for the number of installed drive bays and MEMs.
Carousel unable to move	If you are using one or more MEMs and the carousel did not rotate, confirm the following: <ul style="list-style-type: none"> • The carousel controller cable is attached correctly • The carousel locks have been released • Nothing is blocking the carousel
Inner hard stop on handler's X-axis not removed	If you are using one or more MEMs, make sure that the inner hard stop on the handler's X-axis has been removed, allowing the handler to reach into the MEM.
Battery module not charged	If the Charge LED on the battery module is illuminated, the battery module may not be fully charged. It can take up to 10 minutes for the battery to fully charge.

Table 9-1 Initial troubleshooting steps for power-on error (*continued*)

4. If the error persists, contact Qualstar Technical Support for assistance.

9.2.2 Meanings of the LEDs

This section describes the status LEDs on the library's front panel, on the tape drive assemblies, and on the power supplies.

Front Panel LEDs

[Figure 9-6](#) shows the status LEDs on the front panel of the LRM.



Figure 9-6 Status LEDs on the LRM front panel

[Table 9-2](#) lists the meanings of the status LEDs

LED	State	Indicates
Attention	Slow flash	One or more doors is open or unlocked
	Fast flash	One or more of the light curtain sensors is blocked (for example, a cartridge may be protruding from a slot)
	Solid yellow	One or more I/O ports is open
Network Activity	Flashing green	There is activity on the Ethernet network (currently not implemented)
Library Activity	Steady green	The XLS is powered on and in an error-free state (currently not implemented)
Robot Activity	Flashing green	The handler or the carousel is moving
Fault	Flashing red	The XLS has experienced an unrecoverable error or it has been shut down from X-Link

Table 9-2 Meanings of the status LEDs

Tape Drive Assembly LEDs

[Figure 9-7](#) shows the location of the LEDs on the back of the Fibre Channel tape drive assembly. The SCSI tape drive assemblies include the Drive Status LED only.

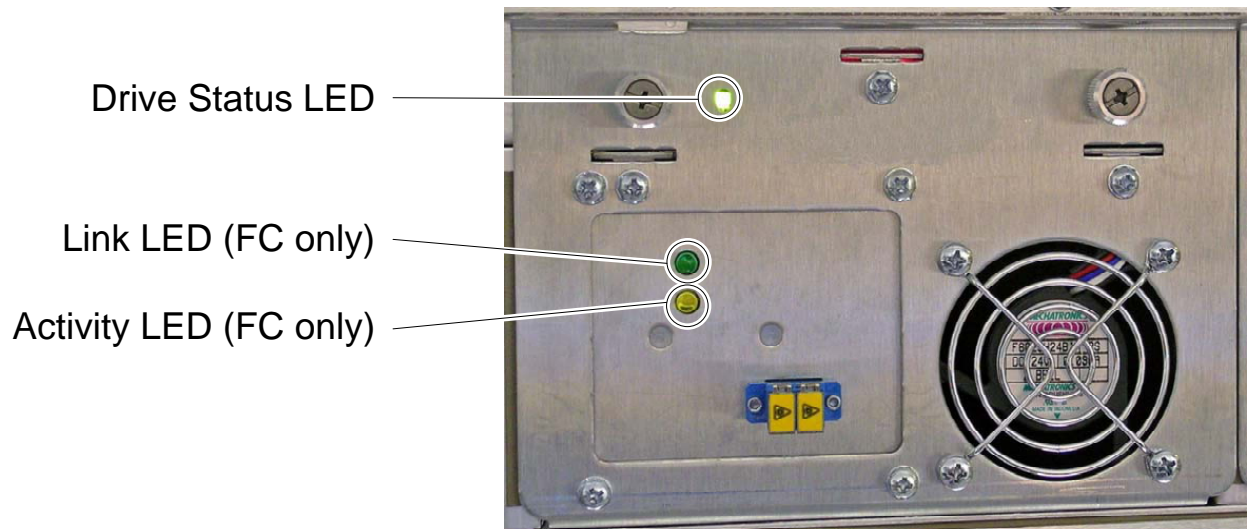

Figure 9-7 Status LEDs on a Fibre Channel tape drive assembly

[Table 9-3](#) lists the meanings of the tape drive LEDs

LED	State	Meaning
Drive Status	Off	The XLS is powered down or the tape drive assembly is not seated correctly
	Amber	The tape drive assembly is installed, but the tape drive is powered off
	Green	The tape drive assembly is installed, and the tape drive is powered on
Link (Fibre Channel carrier only)	Off	The tape drive is not connected to a Fibre Channel switch, or a link is not established
	Green	The tape drive is connected to an active Fibre Channel switch, and a link is established
Activity (Fibre Channel carrier only)	Off	The tape drive is not connected to a Fibre Channel switch, or the switch is off
	Solid yellow	The tape drive is connected to a Fibre Channel switch, but no activity is occurring over the connection
	Flashing yellow	Activity is occurring over the Fibre Channel connection

Table 9-3 Meaning of the tape drive LEDs

Power Supply LEDs

[Figure 9-8](#) shows the location of the two LEDs on the back of each power supply.



Figure 9-8 Power supply status LEDs

[Table 9-4](#) lists the meanings of the LEDs.

LED state		Meaning
PWR Good	Fault	
On (green)	Off	The power supply is operating correctly
On (green)	On (yellow)	The power supply is on, but it is not providing power to the XLS
Off	On	The power supply has failed and needs to be replaced
Off	Off	The power supply has failed and needs to be replaced, or the library is powered down

Table 9-4 Meaning of the power supply status LEDs

9.3 Logging Into X-Link

[Figure 9-9](#) shows the X-Link log-in page. You can log into X-Link using the touch screen or a standard computer keyboard.

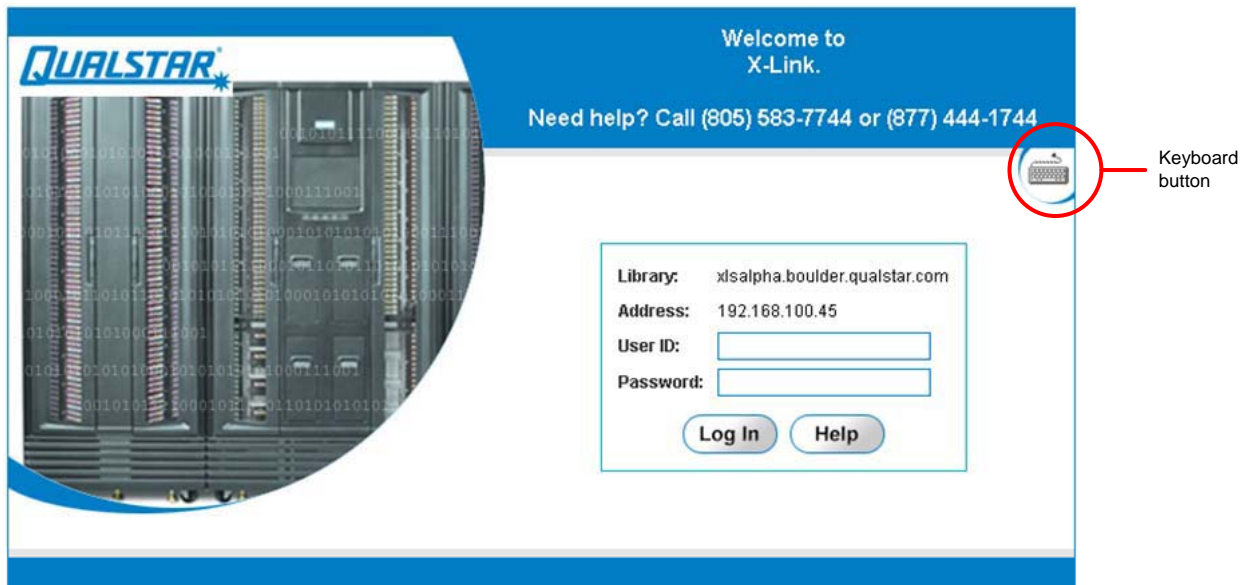

Figure 9-9 Log-in page

To log into X-Link, follow these steps:

1. If you are using a standalone computer, confirm that it is connected to one of the library's Ethernet ports and that it has been configured to access the library. For instructions, see [Section 10.1 on page 10-1](#).

or

If you are using the touch screen, press the keyboard button located on the right side of the log-in page. The virtual keyboard opens, as shown in [Figure 9-10](#).

Note that a stylus has been included with the accessory kit that can be used to control the touch screen. Please be sure to only use the orange colored tip of the stylus on the touch screen as shown in [Figure 9-11](#).

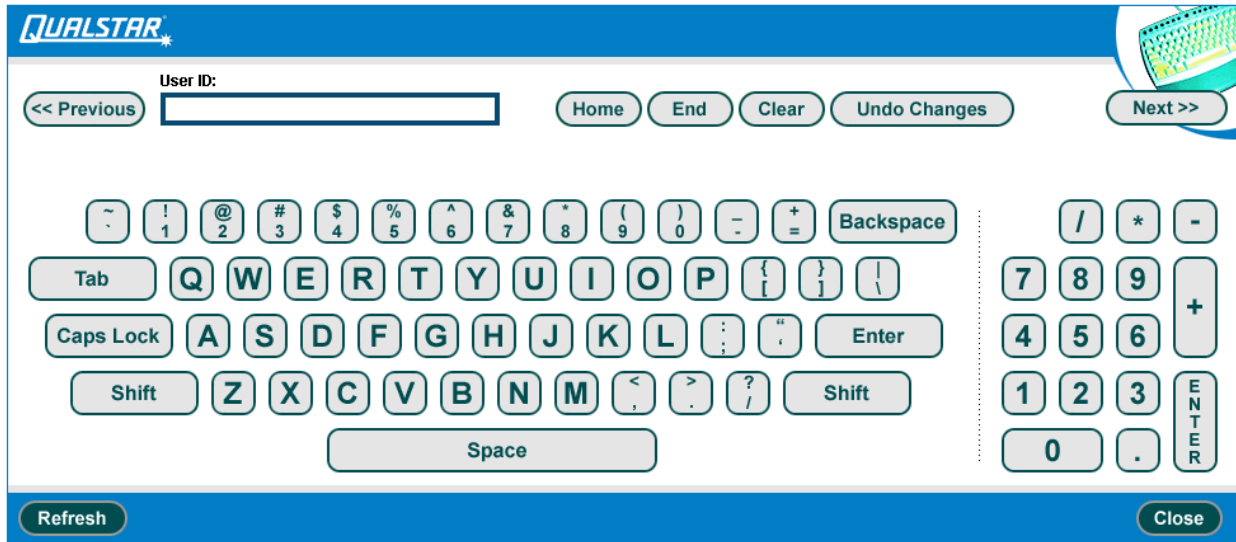

Figure 9-10 Virtual keyboard



Figure 9-11 Touch screen stylus

2. Type your user ID in the **User ID** field.
3. If you are using the touch screen, press **Next** on the virtual keyboard to display the Password field.
4. Type your password in the **Password** field.
5. If you are using the touch screen, press **Close** on the virtual keyboard to return to the log-in page.
6. Press **Log In**. The X-Link Home page opens, as shown in [Figure 9-12](#).

The screenshot displays the X-Link Home page. At the top, there is a navigation bar with the Qualstar logo, the text 'X-LINK INTERFACE', and links for 'Help' and 'Logout'. Below this is a blue header with a 'Refresh' button. The main content area is titled 'X-LINK HOME' and includes the 'COMPASS ARCHITECTURE' logo. The page shows system status: 'Status: All Libraries Online, All Libraries Ready' and 'Doors: All Closed, Locked I/O Ports: All Closed Drives Offline: 0'. There are also 'Event Counts (All Libraries)' showing 'Fault: 0', 'Alert: 0', and 'Last 24 Hours: 3000'. A table titled 'Logical Libraries' is present, with columns for Logical Library Name, Status, Events (Fault / Alert / 24h), Tapes (Total), Storage (Slots / Tapes), Tape Drives (Drives / Tapes, Offline), and I/O Ports (Slots / Tapes, Status). The table shows one library named 'qualstarxls' with an 'Online / Ready' status. Below the table are 'Export options' for CSV, Excel, and XML. At the bottom, there are sections for 'Media and Tape Drives' and 'Administration and Configuration' with various action links. The page also features a timestamp 'Thu Feb 18 10:32:29 MST 2010' and an 'Autorefresh' checkbox. A 'Refresh' button is located at the bottom right of the main content area.

Figure 9-12 X-Link Home page

Notes:

10

Configuring the Physical Library

Once you have successfully powered on the library, you can configure the physical library for use in your environment. The physical library consists of the entire XLS, including the LRM, an attached MEM, an expansion pod, all tape drives, all cartridges slots, all I/O ports, and the handler.

As described in this chapter, configuring the physical library consists of the following activities:

- Connecting the XLS to a standalone or networked computer. See [Section 10.1](#).
- If a MEM or expansion pod is installed, aligning the gripper to the extra slots. See [Section 10.2 on page 10-4](#).
- Verifying the hardware configuration. See [Section 10.4 on page 10-19](#).
- Entering basic information about the XLS, including the library host name, names of contacts and administrators, and target IDs. See [Section 10.5 on page 10-22](#).
- Defining other settings and policies for the library. See [Section 10.6 on page 10-33](#).

10.1 Connecting the XLS to a Computer

Although you can use the touch screen to configure the library, it is much faster to enter configuration information using a standard computer keyboard. For this reason, connect the XLS to a standalone or networked computer. You can use the Ethernet port, as follows:

- The primary Ethernet connector (ENET 0), located on the back of the PC bay, is intended for remote operations across a 10/100 BaseT Ethernet network. See [Figure 10-1](#).



Figure 10-1 Location of the primary Ethernet connector

- The secondary Ethernet connector (the “service port”) is intended for local service operations with a laptop or other standalone computer.

Required tools and equipment: Make sure you have the following:

- A standalone or networked computer running one of the following Internet browsers:
 - Microsoft Internet Explorer 6 (and higher)
 - Netscape 7.2 (and higher)
 - Firefox 1.5 (and higher)
 - Mozilla 1.7.12 (and higher)

Note: While other browsers can be used, Qualstar cannot confirm that the page display and operation will be correct.

- Java Script enabled for the browser.

- Cookies enabled for the browser.

Important: The XLS uses cookies to verify proper login and to “remember” any custom view settings that you select for the browser. At a minimum, you must allow session cookies to prevent X-Link from blocking access to commands. However, if you allow cookies for the session only, any changes you make to the Home page layout will be lost as soon as you log out.

- A CAT5e or better straight-through Ethernet cable

10.1.1 Connecting to a Networked Computer

Important: If your network includes an automatic Dynamic Host Configuration Protocol (DHCP) server and dynamic domain name system (DNS), you can use the primary Ethernet connector (ENET0) for the initial configuration. The library hostname, **qualstarxls**, will be automatically available to the network.

To connect the XLS to a computer on a 10/100 BaseT Ethernet network with a DNS server, follow these steps:

1. Enter the library’s hostname, **qualstarxls**, into the DNS server for the network.
2. Insert one end of the Ethernet cable into the ENET0 port on the back of the library (see [Figure 10-1 on page 10-2](#)).
3. Connect the other end of the cable to the Ethernet switch for the network.
4. Start an Internet browser on a computer on the network.
5. Type the library’s hostname, **http://qualstarxls**, in the address line for the browser. See [Figure 10-2](#).



Figure 10-2 Entering the hostname (Internet Explorer shown)

6. Press **Enter**. The X-Link log-in page is displayed.
7. Log into X-Link as described in [Section 9.3 on page 9-11](#).

10.1.2 Connecting to a Standalone Computer

To connect the XLS to a standalone computer, follow these steps:

1. Set the computer's IP address to the following settings:
 - **IP address:** 192.168.0.245
 - **Subnet mask:** 255.255.255.0
2. Insert one end of the Ethernet cable into the service port (ENET 1).
3. Connect the other end of the cable to the computer's Ethernet port.
4. Start the Internet browser.
5. In the address line for the browser, type the default IP address for the service port, **http://192.168.0.1**. See [Figure 10-3](#).



Figure 10-3 Entering the service port IP address (Internet Explorer shown)

6. Press **Enter**. The X-Link log-in page opens.
7. Log into X-Link as described in [Section 9.3 on page 9-11](#).

10.2 Aligning the Gripper with a MEM

If you have attached a MEM to the LRM, you must align the gripper to the extra slots to ensure that they can be accessed. Aligning the gripper includes the following steps:

- Using the gripper alignment tool to obtain Theta Position (“TPOS”) and X Position (“XPOS”) values (see [Section 10.2.1](#))
- Updating the gripper alignment (see [Section 10.2.3 on page 10-8](#))

Note: If your XLS does not include a MEM, skip this section and go to [Section 10.4 on page 10-19](#).

10.2.1 Using the Gripper Alignment Cartridge

To align the gripper to the carousel, follow these steps:

1. Obtain the gripper alignment cartridge (Qualstar part number: 620059), which is shipped with the MEM or expansion pod. See [Figure 10-4](#).



Figure 10-4 Gripper alignment cartridge

2. From X-Link, press the Home button in the upper right corner of any page to return to the Home page.
3. Select **Service View** to display the Service portlet, shown in [Figure 10-5](#).

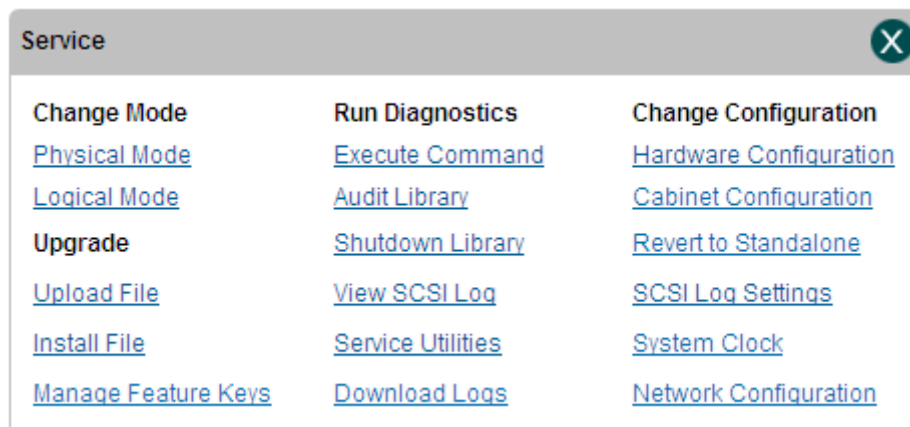

Figure 10-5 Service portlet

4. From the Change Configuration section of the Service portlet, select **Hardware Configuration**. The Hardware Configuration page opens as shown in [Figure 10-7 on page 10-7](#).

5. If the Enter Service Password screen appears (see [Figure 10-6](#)), enter the appropriate password and select Save Changes. If the password is not known or after entering the password it does not allow the Hardware Configuration page to open please contact Qualstar Technical Support for assistance.

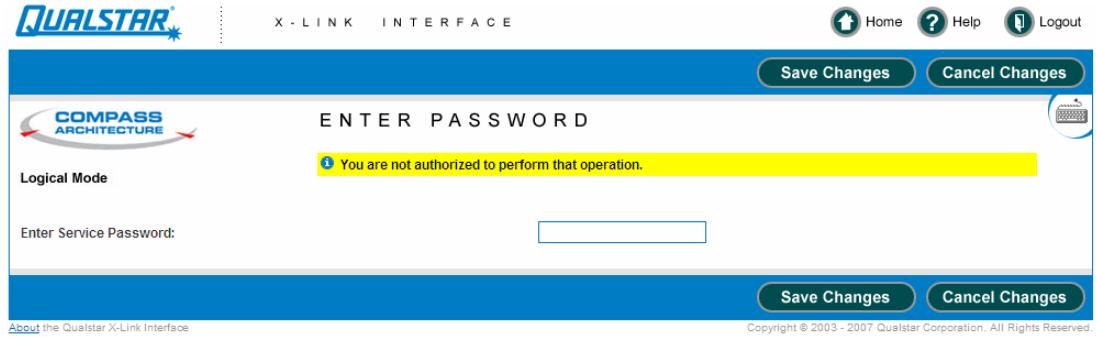

Figure 10-6 Enter Service Password

Figure 10-7 Hardware Configuration

6. From the Robot section, select **Position Robot**, which homes all axes (including any carousels), and positions the gripper to an easily accessible location.
7. Open all doors.

10.2.2 MEM Alignment

To align the gripper to a MEM, follow these steps.

1. Insert the gripper alignment cartridge into slot 36 of the carousel (use whichever column of slots is facing forward). See [Figure 10-8 on page 10-8](#).

Important: Make sure the alignment tool side is facing up that indicates “CAROUSEL 620059-01-4”.



Figure 10-8 Inserting the gripper alignment cartridge into the carousel

2. Move the X-beam by hand and until the gripper assembly is just under the gripper alignment cartridge.

Important: Make sure the alignment cartridge aligns with the gripper assembly guide rod and that it is flush with the gripper and the cartridge slot.

3. From the Robot section of the Hardware Configuration page, select **Get Robot Status**. X-Link displays the gripper's status.
4. Write down the values for the robot's Theta Position ("TPOS") and X Position ("XPOS").
5. Move the X-beam down by hand so that it is not blocking the gripper alignment cartridge.
6. Remove the gripper alignment cartridge.

10.2.3 Updating the Alignment after MEM Calibration

To update the gripper alignment after obtaining the Theta Position and X-Position values, follow these steps:

1. From the Carousels/Pod section of the Hardware Configuration page, locate whichever drop-down list is appropriate for the MEM (that is, either **Carousel/Pod installed on left?** or **Carousel/Pod installed on right?**).

2. After installing a MEM (18 columns of cartridge slots) select **Carousel18** from the list.
3. Press **Save Configuration**. When you press this button, the XLS adds the new MEM slots to its internal databases.
4. Enter the TPOS and XPOS values you obtained while aligning the gripper to the MEM or expansion pod, as follows:
 - In the **Theta 1** field, enter the TPOS value for the MEM.
 - In the **X 1** field, enter the XPOS value for the MEM.
5. Press **Update Alignment**. When you press this button, the XLS updates the gripper alignment so it can access the new slots.

10.3 Calibrating an Expansion Pod Equipped Library

If you have attached a pods to the LRM, you must calibrate the pod to ensure that the extra slots can be accessed.

Note: If your XLS does not include a pod, skip this section and go to [Section 10.4 on page 10-19](#).

Required tools and equipment: Obtain the following:

- Four pod Calibration cartridges (Qualstar part number: 521410) are needed to calibrate each pod

Important: The POD Calibration cartridges are **different** than the Tape Drive Calibration cartridges and they are not interchangeable. POD calibration cartridges must have the CAL label attached.

- Gripper Alignment Cartridge (Qualstar part number: 620059)
- 5/32" Allen wrench
- Flash Light

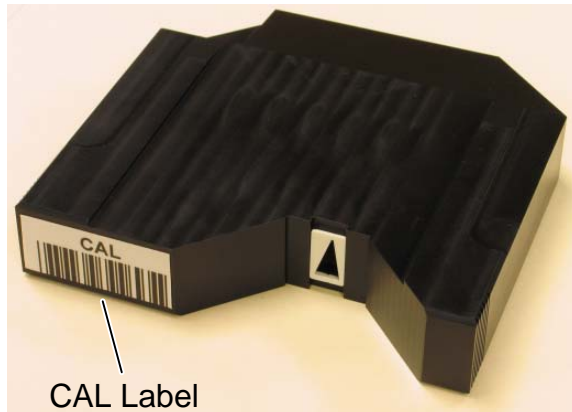

Figure 10-9 Pod calibration cartridge with the CAL label attached

10.3.1 The Calibration Procedure

1. Shut down the XLS Tape Library and switch the power switch to off.
2. Open the LRM door.
3. Expansion pod columns are designated A as the front column, the column closest to the front of the library, and B as the rear column. See [Figure 10-10](#).
4. Make sure the XLS tape library has firmware Version 2.01.F001 PODS SUPPORT or higher installed..



Figure 10-10 Column A and B locations in an expansion pod

5. Insert the four pod calibration cartridges into expansion pod slots **A-5**, **A-60**, **B-5** and **B-60** for each pod.

Note: The pod calibration cartridges should be installed in the **TOP MOST** slot, (slot 60) and the **FIFTH** slot from the bottom, **NOT** the bottom most slot.

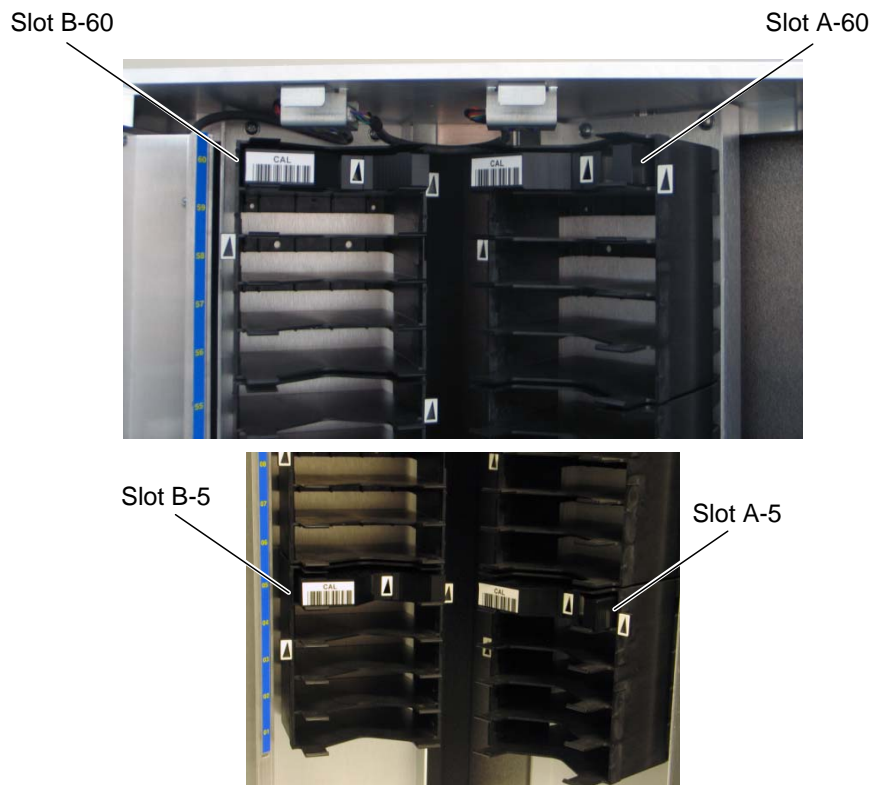

Figure 10-11 Correct locations for the pod calibration cartridges in columns A and B

6. Make sure the pod calibration cartridges are pushed all the way back into the slot and fully seated down in the slot behind the magazine gravity lips.

7. If the inner hard stop on the left side of the X-beam has not already been removed, use a 5/32" Allen wrench to remove the cap screw. See [Figure 10-12](#).

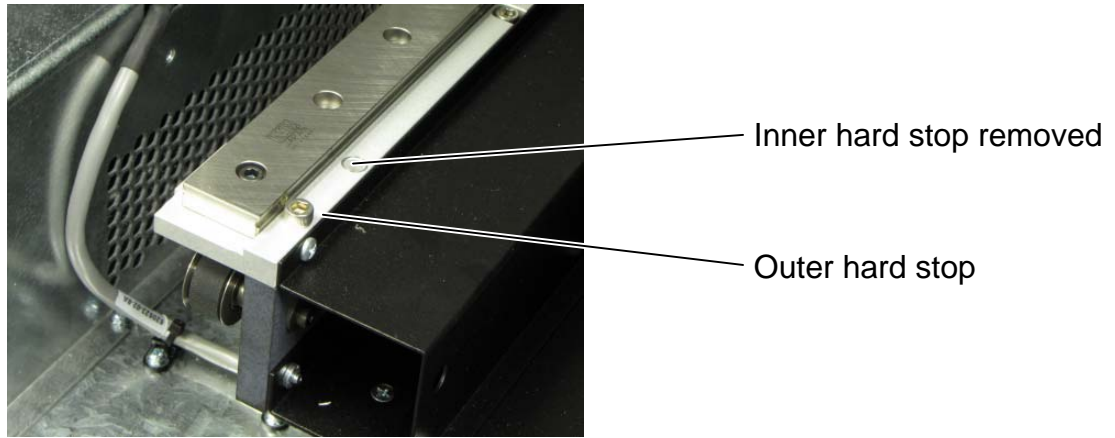

Figure 10-12 Inner hard stop removed on the handler's X-axis (left side shown)

CAUTION

Never remove the outer hard stop or damage to the Library will occur.

8. Make sure the LRM door is open.
9. Power on the XLS Tape Library.
10. Login to the X-link Interface using the Administrator account and password.

11. From the X-link home page, select Service View to display the Service portlet as shown in [Figure 10-13](#).

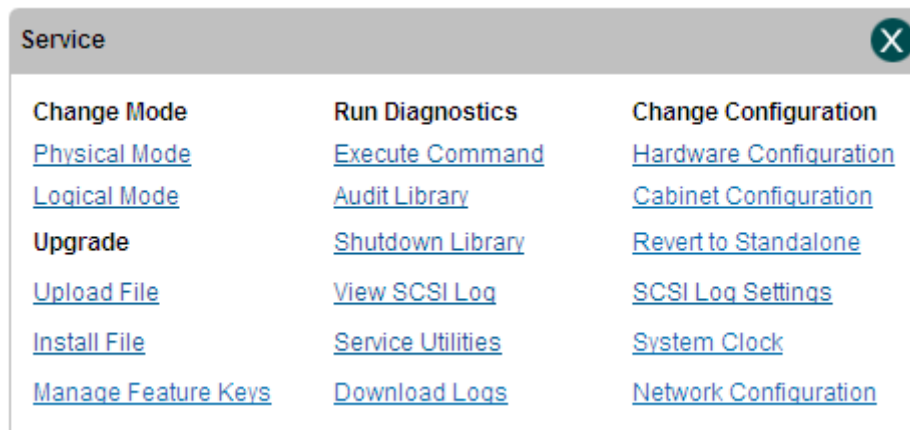

Figure 10-13 Service portlet

12. From the Change Configuration section of the Service portlet, select Hardware Configuration. The Hardware Configuration page opens as shown in [Figure 10-15 on page 10-14](#)
13. If the Enter Service Password screen appears (see [Figure 10-14](#)), enter the appropriate password and select Save Changes. If the password is not known or after entering the password it does not allow the Hardware Configuration page to open please contact Qualstar Technical Support for assistance.

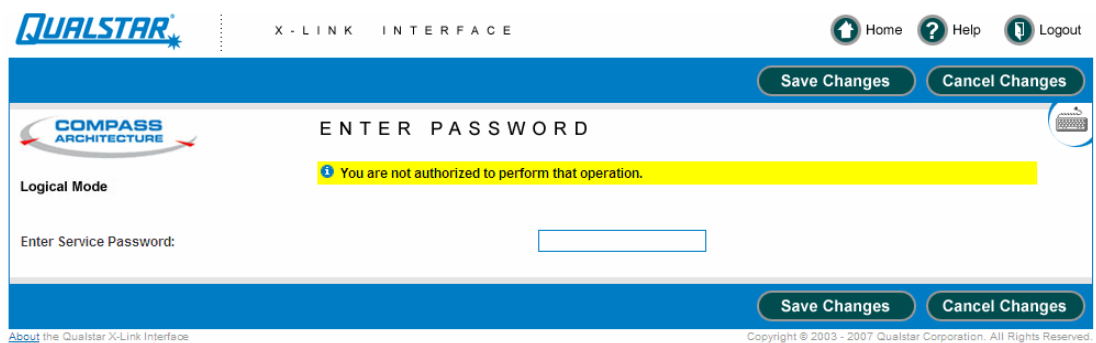

Figure 10-14 Enter Service Password

Figure 10-15 Hardware Configuration

14. Close the XLS Tape Library door, but **do not lock** it.
15. From the Robot section, select **Position Robot**, which homes all axes and positions the gripper to an easily accessible location.
16. Move the Y-axis down by hand slowly until the gripper is level with slot 25.
17. Make sure the Gripper Alignment Cartridge indicates, “THIS SIDE UP FOR THETA ALIGNMENT” or with “BASE” facing upward.

10.3.2 For the Expansion Pod

1. Insert the Gripper Alignment Cartridge into slot 30 - column A (A-30) of the expansion pod. Make sure the tool is fully inserted and seated in the slot.
2. Move the gripper assembly over until it is positioned under the Gripper Alignment Cartridge.

3. Turn the gripper assembly Theta-axis (330 degrees rotation of the gripper assembly) until the gripper is aligned with the Gripper Alignment Cartridge.
4. Slowly raise the X-Beam by hand until the gripper assembly is touching the bottom of the Gripper Alignment Cartridge.

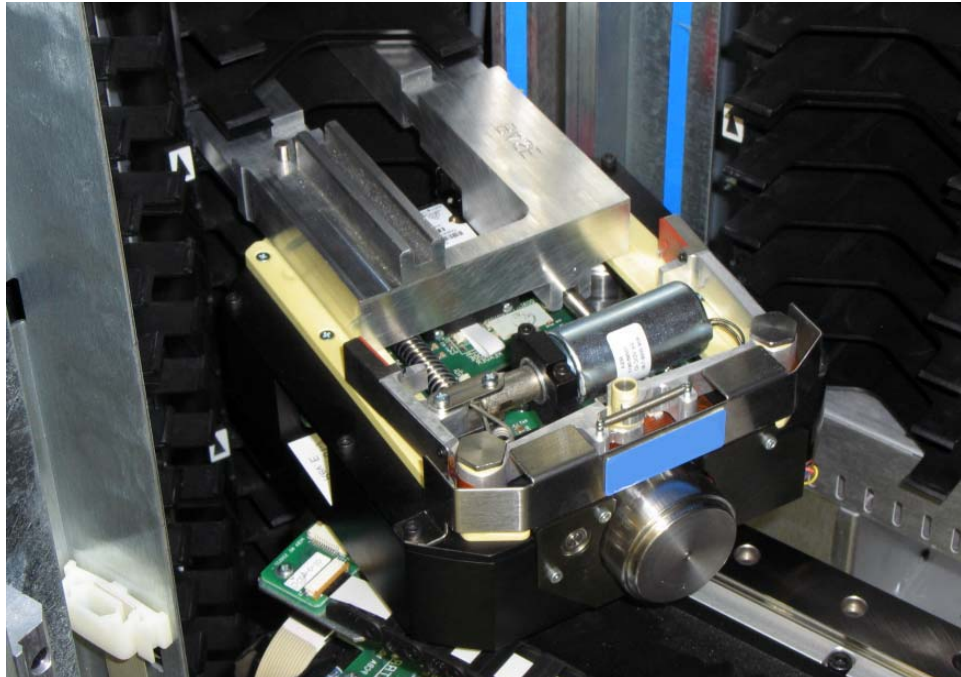

Figure 10-16 Gripper alignment cartridge seated on the gripper assembly

Note: Make sure the gripper alignment cartridge is aligned with the gripper assembly guide rod. Please verify this alignment using a flashlight. You may need to adjust the gripper alignment cartridge up and down to insure that it is properly seated with the front and back of the gripper assembly and the cartridge slot.

5. From the Robot section in X-link, select Get Robot Status to read the robot positions.
6. Record the robot XPOS (X Position) and TPOS (Theta Position) (yaw).
7. Repeat this alignment procedure at least 3 to 6 times until you see consistent reading results.

8. Record the measured TPOS (Theta position) (yaw) and XPOS (X Position) for each column, A and B values in [Table 10-1](#).

Left Side A		Left Side B	
X	Theta (yaw)	X	Theta (yaw)
Average X	Average Theta (yaw)	Average X	Average Theta (yaw)

Table 10-1 Measured values for right side expansion pod

9. Push the Y-axis down and remove the Gripper Alignment Cartridge from slot 30 - column A (A-30).
10. Insert the Gripper Alignment Cartridge into slot 30 - column B (B-30).
11. Repeat the above steps 2 through 8 with the Gripper Alignment Cartridge for Column B.

10.3.3 Find the Average X and Theta Values

1. Add the X position values for each column and find the average value.
2. Add the Theta position values for each column and find the average value.
3. Record the average value for each X and Theta position in the tables for both A and B columns.

10.3.4 Hardware Configuration

1. From the X-link home page, select **ServiceView** to display the Service portlet as shown in [Figure 10-17](#).



Figure 10-17 Service portlet

- From the Change Configuration section of the Service portlet, select **Hardware Configuration**. The Hardware Configuration page opens as shown in [Figure 10-18](#).

Figure 10-18 Hardware Configuration

- Under the Carousels/Pods section, select Pod2 from the appropriate drop-down list. (**Carousel/Pod installed on left**).
- Input the average Theta position (yaw) values as recorded above into the **Theta A** and **Theta B** fields.
- Input the average X position values as recorded above into the **X A** and **X B** fields.
- Select **Save Configuration** to regenerate all databases and update the alignment values.

7. Once the new databases are generated, please verify that the following message appears in the report, “**database generation phase completed without errors**”. You will find this information at the end of the generated report. See example in [Figure 10-19](#).

```

***----- configureLibrary: database generation phase completed without errors. -----***

  Not performing any scans etc. Please complete other steps manually:
  Extra steps needed are (at least) -
  ** scan_fid
  ** scan_io_ports
  ** calibrate
  ** scan_inv
  ** sync_inv
  ** scan_drives

-- newConfigFiles() called. Replacing prev config files.
-- copyFile() : Copying file /xls/config/cabGeometryCandidate.xml to /xls/config/cabGeometry.xml
-- copyFile() : Copying file /xls/config/robot_alignmentCandidate.xml to /xls/config/robot_alignment
-- copyFile() : Copying file /xls/config/libconfigCandidate.xml to /xls/config/libconfig.xml

*** If it displays 'database generation phase completed without errors.' message
*** above then follow these steps:

- If you have just added a carousel, go to the Service Utilities page to Position
  Robot and get the Robot Statistics.
  Once you have them, return to this screen, enter the values, and press Configure
  Hardware again to update the Theta and X values.

- If you have just changed Bays, I/Oports, or Doors, use the Service Utilities
  page to Scan/Calibrate Fiducials and Scan Inventory.

- If you have just updated Theta or X values, use the Service Utilities page to
  Scan/Calibrate Fiducials and Scan Inventory.

```

Figure 10-19 Hardware Configuration “database generation phase completed without errors” screen

8. The pod calibration is now complete and please see [Chapter 13, “Scanning the Fiducials and Inventory”](#) to scan the fiducials, calibrate and scan the inventory (Audit Library).

10.4 Verifying the Hardware Configuration

When it manufactures the XLS to your specifications, Qualstar creates a unique hardware database describing the configuration of the library. The XLS uses the information in this database to help it locate the tape drives, cartridge slots, I/O ports, MEM, and expansion pod.

When you first install the XLS, you should review the hardware configuration in X-Link and verify that it matches the hardware you actually have installed. This step is especially important if you made any changes to the hardware configuration during installation (for example, you added a MEM or changed the location of a drive bay).

To verify the hardware configuration, follow these steps:

1. If necessary, press the **Home** button in the upper right corner of any page to return to the Home page.
2. From the Home page, select **Service View** to display the Service portlet, shown in [Figure 10-20](#).

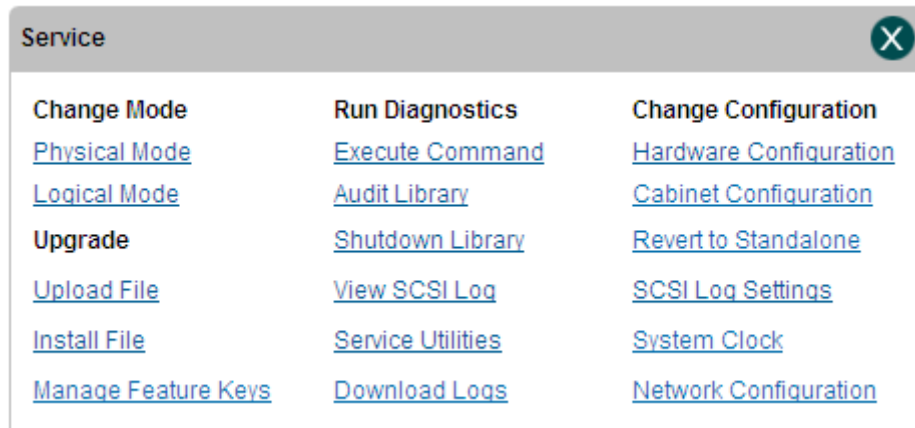

Figure 10-20 Service portlet

3. From the Change Configuration section of the Service portlet, select **Hardware Configuration**. The Hardware Configuration page opens, as shown in [Figure 10-21 on page 10-21](#).

COMPASS ARCHITECTURE

VIEW/EDIT HARDWARE CONFIGURATION

Logical Mode

Library: qualstarxls - qualstarxls ◆ = Required

Model: XLS-810240 Base Unit: 001 ◆

Bays (select use)

Bay E Drive Bay

Bay D ▼

Bay C ▼

Bay B ▼

Bay A ▼

Doors

Door has slots? No

Carousels/Pods

Internal Theta: ◆ Internal X: ◆

Carousel/Pod on left? ▼ ID:

Theta: X:

Theta: X:

Carousel/Pod on right? ID:

Theta A: X A:

Theta B: X B:

Robot Configuration

Back wall theta: ◆

Front wall theta: ◆

Hard stop offset: ◆

Misc

[Go to Physical Mode](#)

[Unlock Doors](#)

[Lock Doors](#)

[Go to Logical Mode](#)

[Cabinet Configuration](#)

Robot

[Power Off Gripper](#)

[Power On Gripper](#)

[Position Robot](#)

[Get Robot Status](#)

Fiducials

[I/O Ports](#) [Calibrate All](#)

[All Slots](#) [Dump Database](#)

[Tape Drives](#) [Unscanned Slots](#)

Inventory

[Scan Inventory](#)

I/O Ports (select use)

Upper Left	<input type="text" value="None"/>	Upper Right	<input type="text" value="None"/>
Lower Left	<input type="text" value="Front panel slots"/> ▼	Lower Right	<input type="text" value="I/O Port"/>

Save Configuration Update Alignment Done

Figure 10-21 Hardware Configuration page

4. In the **Bays** section of the page, review the information displayed for each bay position. Make sure that the cartridge and drive bays are shown in their correct positions.
5. In the **Doors** section of the page, review the information displayed for the door. Make sure the correct information is displayed.
6. In the **I/O Ports** section of the page, review the information displayed for the I/O ports and fixed port assemblies. Make sure that the correct information is displayed.

7. In the **Carousels** section of the page, make sure that the correct information is displayed for an attached MEM.

Important: [Section 10.2 on page 10-4](#) provides instructions for obtaining the values for Theta and X.

8. If you changed the hardware configuration during installation or if the information in the file is incorrect for any other reason, enter the correct information.
9. If the hardware configuration is accurate, press **Done**.

10.5 Entering Configuration Information

After connecting the XLS to a network and logging in, you can enter basic configuration information for the library, including the following:

- Network address (see [Section 10.5.2 on page 10-23](#))
- Contact names and addresses (see [Section 10.5.3 on page 10-25](#))
- Administrator name and address (see [Section 10.5.4 on page 10-26](#))
- Target IDs for the HBAs and the tape drives (see [Section 10.5.5 on page 10-29](#)).

10.5.1 Accessing the Configuration Portlet

To access the Configuration portlet, follow these steps:

1. If necessary, press the **Home** button in the upper right corner of any page to return to the Home page.

2. Select **Administrator View** or **Show All** to display the Configuration portlet, shown in [Figure 10-22](#).



Figure 10-22 Configuration portlet

[Table 10-2](#) lists the fields on the Configuration portlet.

Field	Description
IP Address	The IP address for the XLS library
Hostname	The host name for the XLS library

Table 10-2 Fields on the Configuration portlet

10.5.2 Entering the Network Configuration

This section describes how to view and edit the physical library's network configuration, which includes the library host name and the IP address.

Important: Before changing the network configuration, contact your network administrator for the correct values. An incorrect network setting can cause the XLS or another device on the network to become unavailable.

To view or edit the network configuration, follow these steps:

1. Access the Configuration portlet as described in [Section 10.5.1 on page 10-22](#).

2. Select **View/Edit Network Configuration**. The View/Edit Network Configuration page opens, as shown in [Figure 10-23](#).

Figure 10-23 View/Edit Network Configuration page

3. If you want to change the name for the physical library, enter a new name in the **Library Hostname** field.
 - If your network uses static IP addresses, the name will be displayed in X-Link, but you must update the dynamic domain name system (DNS) on your network to make the library name available to the network.
4. As required, enter information for the **IP Address**, **Subnet Mask**, and **Default Gateway** fields.

Important: If you change the IP address, you must direct your browser to the new address after exiting this page.

5. As multicabinet installations, enter information for the **IP Address** and **Subnet Mask** fields
6. Press **Save Changes** to save the information.
7. If you changed the IP address for the library, redirect the Internet browser to the new address.

10.5.3 Entering Contact Information

This section describes how to view and edit contact information for the physical library. The primary and secondary contacts are typically responsible for the department or division that manages the XLS library.

Important: The information listed for the Primary and Secondary Contact Information fields is for display purposes only. The XLS does not use this information. If you want the contacts listed to receive e-mail or pager alerts, be sure to define them as library users. See the *XLS-810160/810240 Tape Libraries User's Guide* for more information.

To view or edit contact information for the physical library, follow these steps:

1. Access the Configuration portlet as described in [Section 10.5.1 on page 10-22](#).
2. Select **View/Edit Contact Information**. The View/Edit Contact Information page opens, as shown in [Figure 10-24](#).

Save Changes Cancel Changes

COMPASS ARCHITECTURE VIEW/EDIT CONTACT INFORMATION

Logical Mode

Library: xlsalpha.boulder.qualstar.com - (physical) ◆ = Required ◆ = Required if Secondary Contact is specified

Primary Contact Information	Secondary Contact Information
Name: John Smith ◆	Name: Sally Jones ◆
Primary E-mail Address: jsmith@example.com ◆	Primary E-mail Address: sjones@example.com ◆
Alternate E-mail Address: contact1@example.com	Alternate E-mail Address: Contact2@example.com
Pager E-mail Address:	Pager E-mail Address:
Work Phone Number: 303 333 2222 ◆	Work Phone Number: 303 333 2223 ◆
Mobile Phone Number: 303 333 2222	Mobile Phone Number: 303 333 2223
Company:	Company:
Street Address: 1 Example Way	Street Address: 1 Example Way
City / Town / Locality: Example View	City / Town / Locality: Example View
State / Province: CO	State / Province: CO
Zip / Postal Code: 80111	Zip / Postal Code: 80111
Country: USA	Country: USA

Save Changes Cancel Changes

Figure 10-24 View/Edit Contact Information page

3. View or edit the contact information for the library. Required fields are denoted by an arrow.

4. Press **Save Changes** to save the information.

10.5.4 Entering Administrator Information

This section describes how to view and edit administrator information for the physical library. The physical library administrator is the person who has permission to perform administrative tasks on the entire XLS library.

Important: The information listed for the Physical Library Administrator fields is for display purposes only. The XLS does not use this information. If you want the user listed to have permission to perform administrator tasks, you must define him or her as a library user and assign him or her to the appropriate user group. Refer to the *XLS-810160/810240 Tape Libraries User's Guide* for more information.

To view or edit administrator information for the physical library, follow these steps:

1. Access the Configuration portlet as described in [Section 10.5.1 on page 10-22](#).
2. Select **View/Edit Administrator Information**. The View/Edit Administrator Information page opens, as shown in [Figure 10-25](#).

COMPASS ARCHITECTURE

VIEW/EDIT ADMINISTRATOR INFORMATION

Logical Mode

Library: xlsalpha.boulder.qualstar.com - (physical) ◆ = Required

Administrator Information	
Name:	Richard Doe ◆
User ID:	rdoe ◆
Primary E-mail Address:	rdoe@example.com ◆
Alternate E-mail Address:	admin@example.com
Work Phone Number:	805 111 2222 ◆
Mobile Phone Number:	303 333 2222
Pager E-mail Address:	
Company:	
Street Address:	100 Example Plaza
	Suite 200
City / Town / Locality:	Example Heights
State / Province:	CA
Zip / Postal Code:	90333
Country:	USA

Save Changes Cancel Changes

Save Changes Cancel Changes

Figure 10-25 View/Edit Administrator Information page

3. View or edit the administrator information for the library. Required fields are denoted by an arrow.
4. Press **Save Changes** to save the information.

Changing the Administrator Password

When the library is shipped, the default user ID is **admin**. This user has permission to perform all tasks.

CAUTION

To prevent unauthorized users from logging into the XLS, you must change the password for the default user, as described in this section.

To change the administrator password, follow these steps:

1. If necessary, press the **Home** button in the upper right corner of any page to return to the Home page.
2. Select **Administrator View** to display the Users & Groups portlet, shown in [Figure 10-26](#).



Figure 10-26 Users & Groups portlet

3. From the Users & Groups portlet, select **Manage Users & Groups**.
4. In the User ID field, enter **admin**.
5. Press **Select** to select the admin user.

6. Select **Change Password**. The Change User Password page opens, as shown in [Figure 10-27](#).

The screenshot shows a web interface for changing a user password. At the top, there is a blue header with the COMPASS ARCHITECTURE logo on the left and two buttons, 'Save Changes' and 'Cancel Changes', on the right. Below the header, the title 'CHANGE USER PASSWORD' is centered. Underneath, there is a section for 'Logical Mode' with the text 'Library: xisalpha.boulder.qualstar.com - (physical)' and a small icon of a keyboard with the text '* = Required'. The main section is titled 'Change Password' and contains the following fields: 'Name: Qualstar Administrator', 'User ID: admin', 'New Password: [input field with asterisk]', and 'Re-type New Password: [input field with asterisk]'. At the bottom of the page, there are two buttons, 'Save Changes' and 'Cancel Changes'.

Figure 10-27 Change User Password page

7. Enter and re-enter the new password. Passwords:
 - Are case sensitive
 - Must contain between 6 and 32 characters
 - May contain alphabetic or numeric characters
8. Press **Save Changes** to save the new password. Note that you must log in again for the changes to take effect.

10.5.5 Editing the Target IDs

Important: Before changing the default target IDs, review any requirements for the software application.

[Figure 10-28](#) shows the factory-default target IDs for the HBA ports and the tape drives.

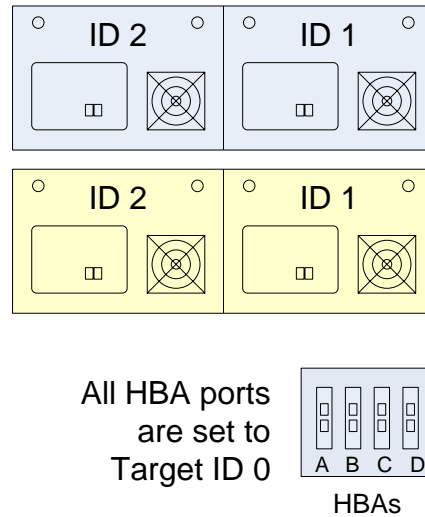

Figure 10-28 Default target IDs for tape drives and HBAs (view from back of LRM)

[Table 10-3](#) summarizes the ranges and default values for the target IDs.

Type of interface	Target ID range	Default setting	
Fibre Channel	0 to 125	Library HBA port	0
		Tape drive	2 or 1*
SCSI	0 to 15	Library HBA port	0
		Tape drive	2 or 1*

* The default IDs for the tape drives match the physical address of the tape drives within the drive bay.

Table 10-3 Target IDs for tape drives and HBAs

Editing HBA Target IDs

By default, the target ID for each HBA port is set to 0. To change the target ID for an HBA port, follow these steps:

1. If necessary, press the **Home** button in the upper right corner of any page to return to the Home page.

2. Select **Administrator View** or **Show All** to display the Configuration portlet, shown in [Figure 10-29](#).



Figure 10-29 Configuration portlet

3. Select **View/Edit HBA Target ID**. The View/Edit HBA Target ID page opens, as shown in [Figure 10-30](#).

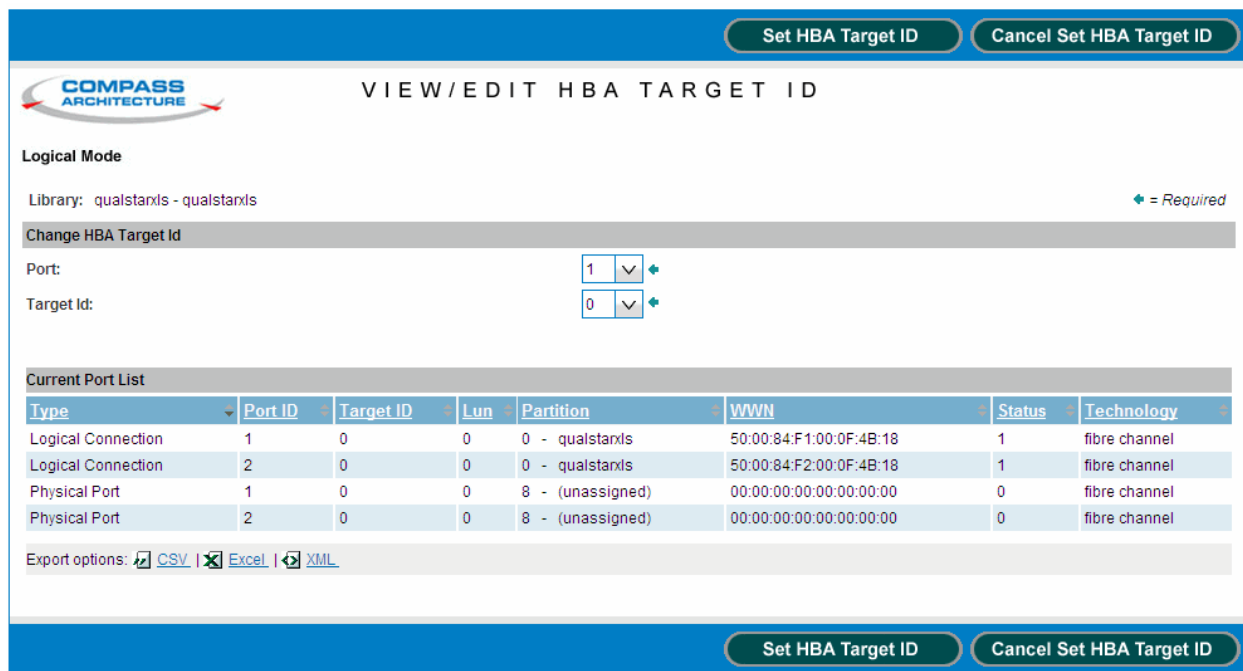

Figure 10-30 View/Edit HBA Target ID page

- In the **Host Bus Adapter** drop-down list, select the HBA port you want to change the target ID for. Since the XLS supports four HBAs with two ports each, up to eight HBA port numbers may be displayed. [Figure 10-31](#) shows how these numbers correspond to the ports' physical locations in the system controller.

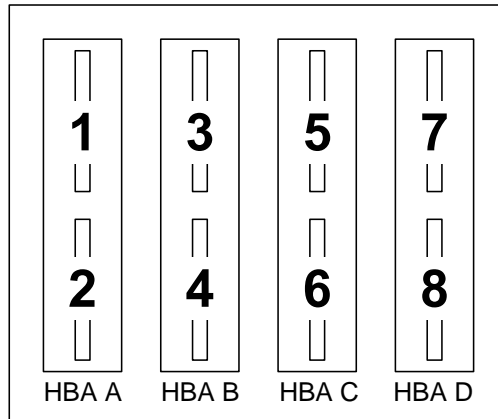

Figure 10-31 HBA port numbers (view from the back of the library)

- In the **Target Id** drop-down list, select a new target ID for the HBA port.
- Press **Save HBA Target ID** to save the information. The new target ID takes effect as soon as the confirmation page appears.

Editing Tape Drive Target IDs

Within a drive bay, the default target IDs for the tape drives range from 2 to 1, which match the physical addresses of the tape drive positions. See [Appendix A, “Library Addresses.”](#)

To change the default target ID for a tape drive, follow these steps:

- Access the Configuration portlet as described in [Section 10.5.1 on page 10-22](#).

2. Select **View/Edit Tape Drive Target ID**. The View/Edit Tape Drive Target ID page opens, as shown in [Figure 10-32](#).

COMPASS ARCHITECTURE

VIEW/EDIT TAPE DRIVE TARGET ID

Logical Mode

Library: xlsalpha.boulder.qualstar.com - (physical) * = Required

Change Tape Drive Target Id

Base Unit: Base Unit B001 *

Column: 1 *

Row: A *

Target: 0 *

Figure 10-32 View/Edit Tape Drive Target ID page

3. Enter the location of the tape drive, as follows:
 - a. From the **Base Unit** drop-down list, select the LRM that contains the tape drive you want to edit the target ID for.
 - b. From the **Column** drop-down list, select the location of the tape drive within the drive bay (where 1 is the rightmost position and 2 is the leftmost position when the library is viewed from the back).
 - c. From the **Row** drop-down list, select the location of the drive bay (where A is the bottom drive bay position and E is the top drive bay position).
4. In the **Target Id** drop-down list, select a new target ID for the tape drive.
5. Press **Save Tape Drive Target ID** to save the information. For Fibre Channel tape drives, the new target ID takes effect as soon as the confirmation page appears. For SCSI tape drives, the new target ID takes effect after the next power-on or SCSI bus reset.

10.6 Defining Other Library Settings and Policies

After logging in and entering basic configuration information, you can create one or more logical libraries and complete the installation process. However, you may want to define additional physical library settings now, before defining the logical libraries. These physical library settings include the following, which are available from the Settings & Policies portlet:

- E-mail settings (see [Section 10.6.2 on page 10-34](#))
- SNMP settings (see [Section 10.6.3 on page 10-36](#))
- Event log settings (see [Section 10.6.4 on page 10-36](#))
- Library policies (see [Section 10.6.5 on page 10-37](#))

10.6.1 Accessing the Settings & Policies Portlet

To access the Settings & Policies portlet, follow these steps:

1. If necessary, press the **Home** button in the upper right corner of any page to return to the Home page.
2. Select **Administrator View** or **Show All** to display the Settings & Policies portlet, shown in [Figure 10-33](#).



Figure 10-33 Settings & Policies portlet

10.6.2 Viewing and Editing E-Mail Settings

This section describes how to view and edit e-mail settings for the physical library. The XLS uses these settings to determine whether to send e-mail alerts to designated users when certain events occur.

Important: After configuring the physical library to send e-mail and pager alerts, follow these steps to ensure that individual users can receive the alerts:

- Enable e-mail and pager alerts for the user groups.
- Enable e-mail or pager addresses for the user.
- Set the Event Severity to Email and Event Severity to Page policies.

For instructions, see the *XLS-810160/810240 Tape Libraries User's Guide*.

To view or edit e-mail settings for the physical library, follow these steps:

1. Access the Settings & Policies portlet as described in [Section 10.6.1 on page 10-33](#).
2. Select **View/Edit E-mail Settings**. The View/Edit E-mail Settings page opens, as shown in [Figure 10-34](#).

Figure 10-34 View/Edit E-Mail Settings page

3. If you do not want the system to send e-mail alerts, select **Do not send e-mail alerts** and go to step 4.

or

If you want to send e-mail alerts, select **Send e-mail alerts** and specify the settings listed in [Table 10-4](#).

Field	Specify this information
Mail Server Hostname or IP Address	The mail server's host name or IP address. This is the name of the SMTP server that sends the e-mail alerts.
Mail Server Port	The port used by the mail server to send e-mail
Sender Name	The name that is to appear as the sender of the e-mail alerts (for example, Qualstar XLS Library)
Sender E-mail Address	The e-mail address to which e-mail recipients can respond (for example, XLS-Administrator@yourcompany.com)

Table 10-4 Settings for e-mail alerts

4. After specifying the e-mail settings, test them by following these steps:
 - a. Enter an e-mail address in the **Test E-mail Recipient** field. You may want to use your own e-mail address, so you can verify that the test e-mail was sent.
 - b. Press **Test Settings**.
 - c. Verify that a test message from the sender specified in the **Sender Name** field arrived in the test e-mail account's mailbox. In some cases, you may have to wait a few minutes to receive the test message.
5. Press **Save Changes** to save the information.

10.6.3 Viewing and Editing SNMP Settings

This section describes how to view and edit the Simple Network Management Protocol (SNMP) settings for the physical library. Data from the SNMP agents, contained in a Management Information Base (MIB), helps in managing the network by showing whether all devices are operating properly.

To view or edit SNMP settings for the physical library, follow these steps:

1. Access the Settings & Policies portlet as described in [Section 10.6.1 on page 10-33](#).
2. Select **View/Edit SNMP Settings**. The View/Edit SNMP Settings page opens, as shown in [Figure 10-35](#).

Figure 10-35 View/Edit SNMP Settings page

3. Enter a name for the SNMP community in the **Community Name** field.
4. Press **Save Changes** to save the information.

10.6.4 Viewing and Editing Event Log Settings

This section describes how to view and edit the event log settings. The XLS uses these settings to determine when to automatically delete entries in the event log.

Note: Refer to the *XLS-810160/810240 Tape Libraries User's Guide* to learn how to delete events manually.

Depending on the values specified, the library deletes events when:

- The number of events in the log exceeds the maximum number specified

- The age of the events in the log exceeds the time period specified

Events are deleted in first-in first-out (FIFO) sequence; that is, the oldest events are deleted first.

To view or edit event log settings, follow these steps:

1. Access the Settings & Policies portlet as described in [Section 10.6.1 on page 10-33](#).
2. Select **View/Edit Event Log Settings**. The View/Edit Event Log Settings page opens, as shown in [Figure 10-36](#).

Figure 10-36 View/Edit Event Log Settings page

3. In the **Maximum # of events to save** field, enter the maximum number of events you want to save in the event log. The library can save a maximum of 1,000 events. As soon as there are more events in the log than this number, the library deletes the oldest event.
4. In the **Save events for** field, enter the number of hours, days, or weeks to save events for. Then, select **hours**, **days**, or **weeks** from the drop-down list. As soon as there are events in the log older than this age, the library deletes them.
5. Press **Save Changes** to save the information.

10.6.5 Viewing and Editing Library Policies

This section describes how to view and edit policies for the physical library. The library uses these settings to determine the following:

- When to send alerts that the library's air filters need to be checked
- When to log off idle users
- What severity of events to e-mail or page users about

To view or edit policy settings for the physical library, follow these steps:

1. Access the Settings & Policies portlet as described in [Section 10.6.1 on page 10-33](#).
2. Select **View/Edit Policies**. The View/Edit Policies page opens, as shown in [Figure 10-37](#).

The screenshot shows the 'VIEW/EDIT POLICIES' page. At the top right, there are 'Save Changes' and 'Cancel Changes' buttons. The page header includes the 'COMPASS ARCHITECTURE' logo and the title 'VIEW/EDIT POLICIES'. Below the header, the 'Logical Mode' section shows 'Library: qualstarxds - qualstarxds' with a blue plus icon and the text '= Required'. The 'Policies' section contains four fields: 'Days until Air Filter Check' with a text input '120' and 'days' and a blue plus icon; 'Minutes before Logging Off Idle Users' with a text input '480' and 'minutes' and a blue plus icon; 'Event Severity to Email' with a dropdown menu showing 'Major'; and 'Event Severity to Page' with a dropdown menu showing 'Fault'. At the bottom of the page, there are 'Save Changes' and 'Cancel Changes' buttons.

Figure 10-37 View/Edit Policies page

3. In the **Days until Air Filter Check** field, specify how often you want the library to send reminders to check the air filters. The default is 120 days; however, you may want to adjust this time to ensure optimum read and write reliability in your operating environment.
4. In the **Minutes before Logging Off Idle Users** field, specify the maximum number of minutes that a user can be idle before being logged off the system automatically. The default session timeout value is 30 minutes.

- From the **Event Severity to Email** drop-down list, select a severity level. The XLS sends email alerts to specified recipients when events of this severity level or above occur. See [Figure 10-38](#).

The screenshot shows the 'VIEW/EDIT POLICIES' screen in the COMPASS ARCHITECTURE software. The 'Logical Mode' section displays 'Library: qualstarxls - qualstarxls' with a required field indicator. Under the 'Policies' section, the following settings are visible:

- Days until Air Filter Check: 120 days
- Minutes before Logging Off Idle Users: 480 minutes
- Event Severity to Email: Any Severity (dropdown menu is open)
- Event Severity to Page: (dropdown menu is open)

The dropdown menu for 'Event Severity to Email' is expanded, showing the following options: Fault, Alert, Major, Minor, Warning, Informational, Other, and Unknown. The 'Save Changes' and 'Cancel Changes' buttons are located at the top right and bottom right of the interface.

Figure 10-38 Specifying event severities for e-mail alerts

- From the **Event Severity to Page** drop-down list, select a severity level. The XLS sends pager alerts to specified recipients when events of this severity level or above occur.
- Press **Save Changes** to save the information.

Notes:

11

Setting Up Logical Libraries

This chapter describes how to create logical libraries and how to print an inventory report for each logical library so you can install the cartridges in the correct locations.

11.1 About Physical and Logical Libraries

The *physical library* consists of the entire XLS system, including the LRM, an attached MEM or expansion pod, all tape drives, all cartridges slots, all I/O ports, the medium changer interface, the robotics, and all HBAs in the system controller's expansion slots.

When the XLS is installed, the resources in the XLS physical library are subdivided into one to eight partitions, called *logical libraries*. These logical library partitions ensure that different software applications have restricted and dedicated access to specific tape drives, cartridge slots, and I/O ports. All logical libraries share access to the XLS's medium changer interface on a first-come, first-served basis.

[Figure 11-1 on page 11-2](#) depicts an example XLS configuration that shows the high-level relationship between the physical library, the logical libraries, the host computers, and the software applications. In the figure:

- Three host computers running three software applications share the XLS physical library.
- To ensure that each software application has its own dedicated set of resources, the physical library has been partitioned into three logical libraries. Each software application controls its own logical library.
- Each host computer connects to an HBA port in the library's system controller. The software applications communicate across the HBA connections to access the library's medium changer interface.

Note: The connections can be either parallel SCSI or Fibre Channel.

- All host computers communicate with the medium changer interface and share control of the robotics (handler and carousel) on a first-come, first-served basis.
- Each of the three logical libraries contains a subset of the total available tape drives and cartridge slots.

- Logical Libraries 1 and 2 have each been assigned an I/O port, respectively; Logical Library 3 does not have an assigned I/O port.

Important: The 10 slots in a single I/O port cannot be shared among logical libraries. If a logical library needs access to an I/O port, it must be assigned the entire port when the library is defined.

- The software applications and the host computers connect to and communicate with the tape drives independently of the medium changer.

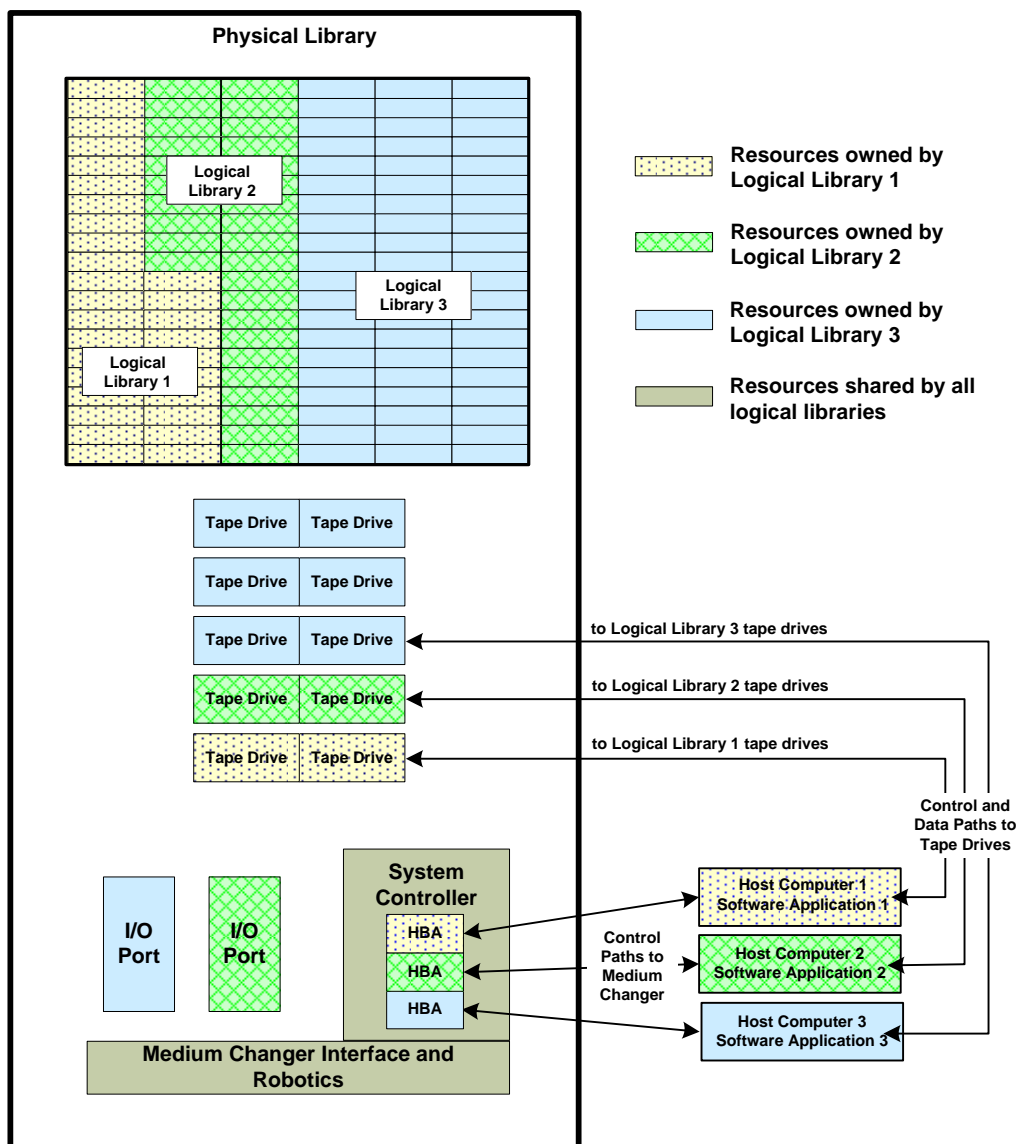

Figure 11-1 Relationship between the physical library, logical libraries, and software applications

Creating More Complex Configurations

[Figure 11-1 on page 11-2](#) depicts a typical and relatively simple XLS configuration—one in which three host computers, each running a single backup application, are connected to three HBA ports on the XLS. In the example, each host controls one logical library, which is a subset of the library's total available tape drives, cartridge slots, and I/O ports.

While this one-host-to-one-logical-library configuration is the most easy to connect, you may want to create more complex configurations to meet more sophisticated data-protection requirements, including equipment failover and backup redundancy.

Important: Because they entail the use of specialized storage management software and customized cabling schemes, these more complex configurations are beyond the scope of this manual. If you require a specialized configuration, work with your system integrator and software vendor.

11.2 Creating a New Logical Library

This section describes how to complete the Create Logical Library wizard to create a new logical library.

Important: If you plan to operate the XLS using only one logical library, you do not need to complete the Create Logical Library wizard.

Instead, refer to the *XLS-810160/810240 Tape Libraries User's Guide* to learn how to customize the settings for the predefined logical library. Using the logical library selections on the Logical Libraries portlet, you can view or edit the logical library's name, the operating mode, the HBA port used for the library, the contact and administrator information, and more.

11.2.1 Accessing Logical Library Information

To access information about logical libraries, follow these steps:

1. If necessary, press the **Home** button in the upper right corner of any page to return to the Home page.

2. Select **Logical Library View** or **Show All** to display the Logical Libraries portlet, shown in [Figure 11-2](#). This portlet provides summary information about all defined logical libraries.

The screenshot shows the 'Logical Libraries' portlet interface. At the top, it displays the status: 'Status: All Libraries Online, All Libraries Ready'. Below this, it shows 'Doors: All Closed, Locked', 'I/O Ports: All Closed', and 'Drives Offline: 0'. To the right, 'Event Counts (All Libraries)' are shown: 'Fault: 0', 'Alert: 0', and 'Last 24 Hours: 3000'. There are four tabs: 'Logical Mode' (selected), 'Physical Mode', 'Lock Doors', and 'Unlock Doors'. A table lists logical libraries with columns for Name, Status, Events (Fault / Alert / 24h), Tapes (Total), Storage (Slots / Tapes), Tape Drives (Drives / Tapes, Offline), and I/O Ports (Slots / Tapes, Status). One library named 'qualstarxis' is listed with status 'Online / Ready' and various counts. Below the table are 'Export options' for CSV, Excel, and XML. At the bottom, there are two sections: 'Media and Tape Drives' and 'Administration and Configuration', each containing several links.

Logical Library	Events	Tapes	Storage	Tape Drives	I/O Ports
Name	Status	Fault / Alert / 24h	Total	Slots / Tapes	Drives / Tapes / Offline
(Unassigned)				0	0
qualstarxis	Online / Ready	0 / 0 / 3000	10	245 / 5	2 / 0 / 0

Figure 11-2 Logical Libraries portlet

11.2.2 Planning New Logical Libraries

When you create a new logical library, you specify the following information, as described in this chapter:

1. A unique name for the logical library. The name can contain 5 to 32 letters and numbers. It cannot contain blanks.
2. The operating mode for the logical library (for software compatibility)
3. Whether barcode labels are required on every cartridge and whether the labels must contain checksum characters
4. The HBA port ID and logical unit number (LUN) for the logical library
5. The number of cartridge slots and I/O ports you want the logical library to contain

Important: If you anticipate wanting to add storage slots to the logical library in the future, consider requesting the extra slots now. Otherwise, the new cartridge slots may not be contiguous to the original slots.

6. The location of the tape drives for the logical library

7. Information about the logical library's administrator and primary and secondary contacts

After creating the logical library, you can generate an inventory report to learn which cartridge slots and I/O ports have been assigned to the logical library. You will use this report to install the cartridges in the correct locations.

Creating a Logical Library Planning Worksheet

If you are planning to partition the entire XLS physical library into more than one logical library, you may want to create a planning worksheet, such as the example in [Table 11-1](#). By creating a worksheet in advance, you can minimize the time required to complete the Create Logical Library wizard and reduce the chances that you will need to edit the logical library definitions later on. As you create the worksheet, refer to the explanations in [Section 11.2.3 on page 11-6](#) to learn the possible values for each option.

Option	Total Available	Log. Lib. 1	Log. Lib. 2	Log. Lib. 3	Log. Lib. 4
Name		LogLib1	LogLib2	LogLib3	LogLib4
Operating Mode		XLS-8000	XLS-8000	XLS-8000	XLS-8000
Barcode labels required?		Yes	Yes	Yes	Yes
Checksum characters required?		No	No	No	No
Port ID used	4 ports (2 cards in HBA slots A and B)	Port ID 1 (upper slot, HBA A)	Port ID 2 (lower slot, HBA A)	Port ID 3 (upper slot, HBA B)	Port ID 4 (lower slot, HBA B)
Logical Unit Number (LUN)		0	0	0	0
Number of slots	200	50	100	25	25
Number of I/O ports	2	1	0	0	1
Number of tape drives	8	2	2	2	2
Location of tape drives and drive slots		row A, 1-2	row B, 1-2	row C, 1-2	row D, 1-2
Administrator		Sally	Mike	Mary	Thomas
Primary Contact		Joe	Joe	Joe	Joe
Secondary Contact (optional)		Richard	Richard	Richard	Richard

Table 11-1 Example worksheet for planning logical libraries

11.2.3 Completing the Create Logical Library Wizard

To complete the wizard, follow these steps:

1. Access the Logical Libraries portlet as described in [Section 11.2.1 on page 11-3](#).
2. At the bottom of the logical libraries table, review how many XLS resources are unassigned (cartridge slots, tape drives, and I/O ports). You can select from these resources when you define the new logical library.

Important: If fewer slots, I/O ports, or tape drives are available than needed, you can delete or edit any existing logical libraries to make the resources available.

3. From the Administration list, select **Create a New Library**. The first Create Logical Library page opens, as shown in [Figure 11-3](#).

The screenshot displays the 'CREATE LOGICAL LIBRARY' wizard interface. At the top, there are 'Next Step >>' and 'Cancel' buttons. The main header reads 'CREATE LOGICAL LIBRARY' and 'STEP 1 OF 3: ENTER LIBRARY SPECIFICATIONS'. Below this, the 'Logical Mode' section is visible. The 'Library Specifications' section contains the following fields:

- Name: [Text input field]
- XLS-8000 Mode:
- Barcode labels required:
- Checksum characters required:
- Port Id: [Dropdown menu with '1' selected]
- Logical Unit Number (LUN): [Dropdown menu with '0' selected]
- Number of Slots: [Text input field with '0', followed by '+ 0 Slots Available']
- Number of I/O Ports: [Text input field with '0', followed by '+ 0 I/O Ports Available']
- Tape Drives: [Text input field, followed by '+ 0 Available: 0 Tape Drives, 0 Empty Slots']

At the bottom of the form, there are 'Next Step >>' and 'Cancel' buttons.

Figure 11-3 Create Logical Library page (step 1 of 3)

4. Enter basic specifications for the library, as follows:
 - a. In the **Name** field, enter a unique name for the new logical library. The name can contain 5 to 32 letters and numbers. It cannot contain blanks.
 - b. In the **XLS-8000 Mode** field, indicate whether you want the medium changer interface for this logical library to operate in XLS-8000 mode. When this box is checked, the XLS reports its Product ID as XLS-8000.

Important: To ensure proper library operation, be sure that the XLS-8000 mode box is checked.

- c. In the **Barcode labels required** field, indicate whether barcode labels are required in this logical library. The default setting is yes (option box checked). If you clear the **Barcode labels required** option, the XLS allows both labeled and unlabeled cartridges in the logical library.
- d. In the **Checksum characters required** field, indicate whether checksum characters are required on the barcode labels used in this logical library. The default setting is no (option box cleared). If you select the **Checksum characters required** option, the XLS uses the last digit on the label as a checksum for the other characters.

Important: If you select the **Checksum characters required** option, all labeled cartridges must include a checksum character as the last digit.

- e. In the **Port Id** drop-down list, select the HBA port for this logical library (that is, specify which HBA port on the back of the library the host computer will be connected to). Depending on how many HBAs are installed in the library, port IDs can range from 1 to 8, as shown in [Figure 11-4](#).

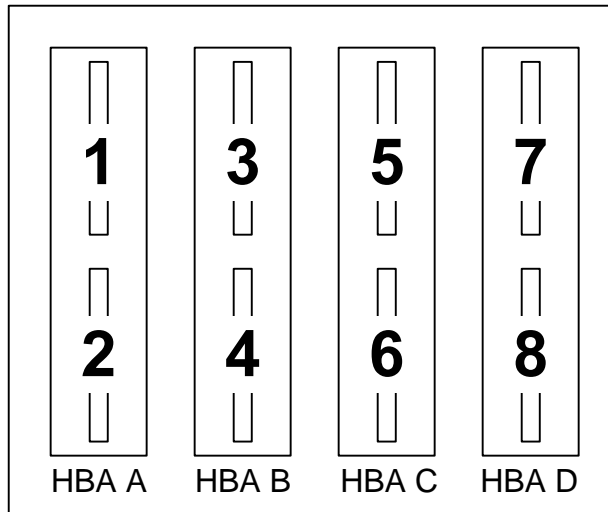

Figure 11-4 Port IDs (view from the back of the LRM)

- f. In the **Logical Unit Number (LUN)** drop-down list, select a logical unit number (LUN) for this logical library. LUN values can range from 0 to 7. The recommended value is 0.
- g. In the **Number of Slots** field, indicate how many cartridge slots you want to allocate to this logical library. Specify a value that is equal to or smaller than the number of available slots.

Important: If you anticipate wanting to add storage slots to the logical library in the future, consider requesting the extra slots now. Otherwise, any new cartridge slots may not be contiguous to the original slots.

- h. In the **Number of I/O Ports** field, indicate how many I/O ports, if any, you want to allocate to this logical library. A logical library can have zero to two I/O ports. Specify a value that is equal to or smaller than the number of available ports.

Important: I/O ports cannot be shared among logical libraries.

- i. In the **Tape Drives** field, select the tape drive locations that will be used by this logical library. Be sure to include installed tape drives and any empty tape drive slots you want to reserve for this logical library. See

[Section 7.1.3, “Recording Tape Drive Locations,” on page 7-10](#) for more information.

- To add a tape drive location (tape drive or empty slot), select the check box next to the location.
- To remove a tape drive location (tape drive or empty slot), clear the check box next to the location.

Note: If a tape drive location is not shown, it has already been assigned to another logical library.

5. Press **Next Step** to continue creating the logical library.

When you press **Next Step**, the second Create Logical Library page opens, as shown in [Figure 11-5](#).

COMPASS ARCHITECTURE

CREATE LOGICAL LIBRARY

STEP 2 OF 3: SPECIFY ADMINISTRATOR

Physical Mode

◆ = Required

Administrator Information

Name:	<input type="text" value="John Smith"/>	Company:	<input type="text"/>
User ID:	<input type="text" value="jsmith"/>	Street Address:	<input type="text"/>
Primary E-mail Address:	<input type="text" value="jsmith@example.com"/>	<input type="text"/>	<input type="text"/>
Alternate E-mail Address:	<input type="text"/>	City / Town / Locality:	<input type="text"/>
Pager E-mail Address:	<input type="text"/>	State / Province:	<input type="text"/>
Work Phone Number:	<input type="text" value="(303) 444-1111"/>	Zip / Postal Code:	<input type="text"/>
Mobile Phone Number:	<input type="text"/>	Country:	<input type="text"/>

Figure 11-5 Create Logical Library page (step 2 of 3)

6. Enter the name and user ID of the person who is to administer the new logical library.

Important: The information you enter in the Logical Library Administrator fields is for display purposes only. The XLS does not use this information. If you want the user listed to have permission to perform administrator tasks, you must define him or her as a library user and assign him or her to the appropriate user group (see the *XLS-810160/810240 Tape Libraries User's Guide*).

7. Press **Next Step** to continue creating the logical library.

When you press **Next Step**, the third Create Logical Library page opens, as shown in [Figure 11-6](#).

Figure 11-6 Create Logical Library page (step 3 of 3)

8. Enter information for the primary contact and, optionally, a secondary contact for this logical library. The primary and secondary contacts are typically responsible for the department or division that owns any data stored on the logical library.

Important: The information listed for the Primary and Secondary Contact Information fields is for display purposes only. The XLS does not use this information. If you want the contacts listed to receive e-mail or pager alerts, be sure to define them as library users (see the *XLS-810160/810240 Tape Libraries User's Guide*).

9. Press **Finish** to create a logical library with the requested number of cartridge slots, tape drives, and I/O ports.

11.3 Viewing the Inventory Report

In order to install cartridges into a logical library (see [Chapter 12, “Loading Cartridges”](#)), you need to know which cartridge slots were assigned to the logical library when it was created.

To view a report showing which slots are assigned to a logical library, follow these steps:

1. Access the Logical Libraries portlet as described in [Section 11.2.1 on page 11-3](#).
2. Select the radio button to the left of the logical library name, then select **View Inventory** from the Media and Tape Drives list.

or

In the Cartridges section of the table, select an underlined hyperlink for the logical library. (This automatically selects the radio button for the logical library.)

The View Inventory page opens, as shown in [Figure 11-7](#).

The screenshot shows the 'VIEW INVENTORY' page for a logical library named 'qualstarxIs'. The page includes a 'MOVE MEDIA' dialog box with 'Source' and 'Destination' fields (set to 2000) and 'Clear All' and 'Move Media' buttons. Below the dialog is a search bar and a table of inventory slots. The table has columns for Cartridge Slot, Library Name, Slot ID, Barcode, and Access. The selected slot is 2005 with barcode A0000256.

Cartridge Slot	Library Name	Slot ID	Barcode	Access
Cartridge Slot, Left Internal Carousel	qualstarxIs	2001	B001L32A	✗ Dest Access
Cartridge Slot, Left Internal Carousel	qualstarxIs	2002	B001L33A	✗ Dest Access
Cartridge Slot, Left Internal Carousel	qualstarxIs	2003	B001L34A	✗ Dest Access
Cartridge Slot, Left Internal Carousel	qualstarxIs	2004	B001L35A	✗ Dest Access
Cartridge Slot, Left Internal Carousel	qualstarxIs	2005	B001L36A	✓ A0000256 Export Load Drive Move Access
Cartridge Slot, Left Internal Carousel	qualstarxIs	2006	B001L37A	✗ Dest Access
Cartridge Slot, Left Internal Carousel	qualstarxIs	2007	B001L38A	✗ Dest Access
Cartridge Slot, Left Internal Carousel	qualstarxIs	2008	B001L39A	✗ Dest Access

Figure 11-7 View Inventory page

3. Review or sort the report as follows:

- To scroll through the report, use the scroll bar on your browser or by selecting the page links ([First/Prev], 1, 2, 3,..., [Next/Last]) if there are more than fivehundred elements shown.
 - To sort the rows in ascending or descending order, press the underlined heading of the column you want to sort by.
4. If the logical library contains more than 200 cartridge slots, display the next group of cartridge slots by selecting the page links ([First/Prev], 1, 2, 3,..., [Next/Last]).

Important: All tape drives and I/O port slots are displayed immediately following the cartridge slots.

5. The inventory report can be filtered to show all slots, only full or empty slots and either storage, I/O port, drive, or all three slot types at once by selecting the appropriate drop-down lists. The report automatically updates when the drop-down lists are changed.
6. To export the inventory report, press **Excel**, **XML**, or **CSV**. Then, as prompted, save the file.
7. Print the report(s) to use when installing cartridges.

[Table 11-2](#) describes the fields in the inventory report. Refer to [Appendix A, “Library Addresses,”](#) to learn the physical location of each column and row position

Field	Description
Element Type	The type of element: tape drive, cartridge slot, or I/O port
Library	The name of the library where the element is located
SCSI Element	The SCSI element address that is currently assigned to this location
Cabinet	A number identifying which LRM or MEM cabinet the element is located in
Column	A letter identifying which column the element is located in. Refer to Appendix A, “Library Addresses,” for more information.

Table 11-2 Fields on View Inventory page

Field	Description
Row	A letter identifying which row the element is located in. Refer to Appendix A, "Library Addresses," for more information.
Media Present	Whether or not a cartridge is present in the element, as follows: ✓ = The element contains a cartridge × = The element is empty
Bar Code	If the element contains a cartridge, the identifier on its barcode label
Action	Lists a variety of operations that can be performed for a particular slot depending on the element type and if media is present. The column may contain: Access, Dest, Eject, Export, Import, Load Drive, Move or Unload Drive. Please see the XLS-810160/810240 Tape Libraries User's Guide for more information.

Table 11-2 Fields on View Inventory page (*continued*)

Notes:

This chapter provides instructions for the following tasks related to loading cartridges into the XLS:

- Installing cartridges in the reserved slots. See [Section 12.1](#)
- Precautions for handling cartridges (see [Section 12.2 on page 12-3](#))
- Preparing cartridges (see [Section 12.3 on page 12-4](#))
- Bulk-loading the data and cleaning cartridges (see [Section 12.4 on page 12-5](#))

Important: You can also install cartridge using the I/O ports. For instructions, refer to the chapter on importing and exporting cartridges in the *XLS User's Manual*.

12.1 Installing Cartridges in the Reserved Slots

Each LRM includes five reserved slots for the tape drive calibration cartridge and four cleaning cartridges. You must install the calibration cartridge in order to calibrate the positions of the tape drives. The cleaning cartridges are used when you request tape drive cleaning from X-Link.

Required tools and equipment: Make sure you have the following:

- The calibration cartridge that was shipped in the XLS accessory kit. See [Figure 12-1](#).



Figure 12-1 XLS calibration cartridge

- Four cleaning cartridges. These will be used whenever tape drive cleaning is requested from X-Link. They are not intended for day-to-day tape drive cleaning operations and are installed in locations that are inaccessible to the software applications.

Procedure: To install cartridges into the five reserved slots, follow these steps:

1. Open the right door.
2. Locate the five reserved cartridge slots in positions A46–A50 on the carousel. The slots are marked with a bright yellow label that reads, “RESERVED DO NOT USE.” See [Figure 12-2 on page 12-3](#).

3. Insert the calibration cartridge in the uppermost reserved slot (A50).

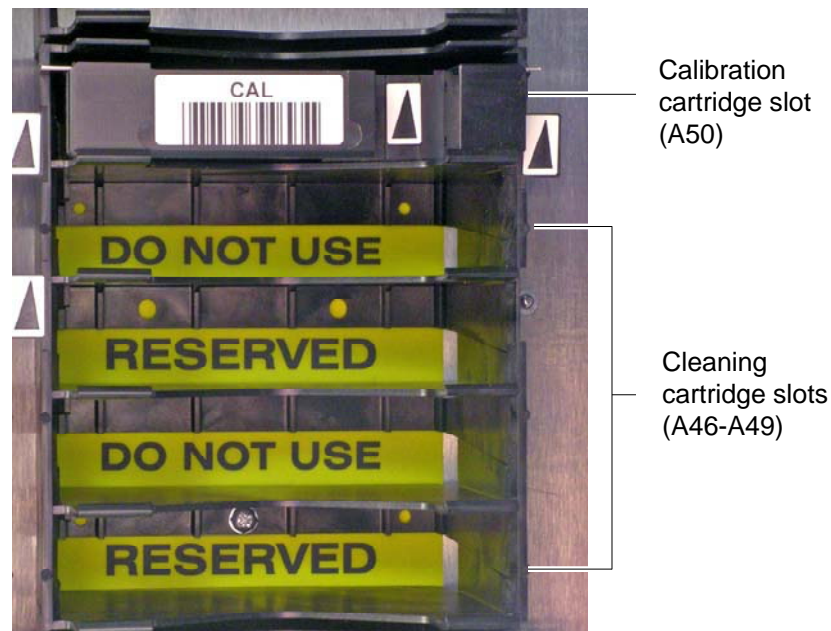

Figure 12-2 Installing the calibration cartridge

Important: To ensure that the tape drive positions are calibrated correctly, you must install the calibration cartridge into slot A50. Do not install any other type of cartridge in this position.

4. Insert at least one new cleaning cartridge into the four slots directly below the calibration cartridges (slots A46–A49).
5. Close any open doors.

12.2 Precautions for Handling Cartridges

Important: Except as required to complete the installation procedures, this manual does not include information about cartridge handling, capacity, or compatibility. Refer to the tape drive manual for more information.

Tape cartridges are fragile and can be damaged if mishandled. To prevent damage to cartridges, follow these guidelines:

- Keep cartridges in their protective plastic cases or in a covered magazine when handling them outside the XLS.

- When carrying more than one LTO cartridge, orient the cartridges the same way and stack them together. Their cases are designed to interlock.
- Never stack cartridges more than five high.
- Before inserting a cartridge into a tape drive, allow it to acclimate to the operating environment for at least 24 hours. You can do this in the same room as the XLS or within the XLS. Inserting a hot or cold cartridge into a tape drive could damage the tape, the tape drive, or both.
- Store cartridges at temperatures between 64–79° F (18–26° C) and at a relative humidity of 40–60%.
- Avoid placing cartridges near any source of high intensity magnetic fields, such as monitors, electric motors, or medical-imaging equipment.
- Never apply adhesive labels to the cartridge anywhere except in the recess provided on the front. Labels applied elsewhere could cause the cartridge to become jammed inside a tape drive or magazine.
- Use only ink when writing on labels. The debris from lead or grease pencils can cause data errors.
- Do not carry cartridges loose in a container. Allowing them to bang together can damage the tape.
- Do not touch or allow direct contact with the tape or tape leader. Dust or natural skin oils can contaminate the tape and affect performance.
- Do not expose the cartridge to moisture or direct sunlight.
- If a cartridge has been dropped, do not load it into a tape drive until it has been inspected for damage. See Qualstar Product Information Note #041, “LTO Tape Cartridge Inspection.”

12.3 Preparing Cartridges

Before installing the cartridges, follow these steps:

1. For each logical library, ensure that you have the appropriate number of data and cleaning cartridges readily available.

- Carefully affix a barcode label to each cartridge, as shown in [Figure 12-3](#).



Figure 12-3 Barcode label location

- Confirm that the labels are on straight and within the recessed area on the cartridge.
- Check the write-protect switches to confirm they are set appropriately.

12.4 Installing Cartridges in Cartridge Slots

This section provides instructions for installing cartridges into the cartridge slots. These instructions assume that you are manually placing the cartridges into the slots rather than importing them into the library using the I/O ports.

You can store cartridges in the following locations:

- Expansion Pods.** As an option, it includes 116 cartridge slots.
- Carousels.** The carousel in an XLS-810160 provides storage slots for 155 cartridges, while a XLS-810240 has 235 storage slots.
- Fixed port assemblies.** If fewer than two I/O ports are installed, the library includes one or more fixed port assemblies behind the front panel. Each fixed port assembly includes 10 cartridge slots.
- MEM.** The carousel of the XLS-85000 MEM includes storage slots for 517 cartridges.

Important: The bottom two rows of storage slots on MEM's are manually inaccessible and tape cartridges must be loaded using the robotic handler and the Move Media option of an attached LRM.

To install the cartridges, follow these steps:

- For each logical library, obtain the inventory report(s) for the logical library. See [Section 11.3, “Viewing the Inventory Report,” on page 11-11](#).

2. Open the library doors.

Important: The library's power can remain on when you insert the cartridges.

3. Refer to the labels within the library or to the figures in [Appendix A, "Library Addresses,"](#) to associate the cabinet, column, and row addresses on the inventory report with the cartridge locations in the LRM and MEM.
4. Ensure that the write-protect switches are to the left, then insert the cartridges into the slots.

Important: Be sure to insert the cartridge all the way into the slot.

5. As required, install cleaning cartridges for each logical library partition. Refer to the software documentation for any special requirements for cleaning cartridges.

Important: Do not install cartridges in the I/O port slots or the tape drives.

6. Close any open doors.

13 Scanning the Fiducials and Inventory

This chapter provides instructions for the following tasks:

- Preparing to scan the library (see [Section 13.1](#))
- Scanning and calibrating the *fiducials* (see [Section 13.2 on page 13-2](#))
- Scanning the inventory and locking the doors (see [Section 13.3 on page 13-6](#))

Important: Fiducial scans should **NOT** be performed without guidance from Qualstar Technical Support.

13.1 Before You Begin

Before scanning and calibrating the fiducials and cartridge inventory, follow these steps:

1. Open the door on the XLS.
2. Check the cartridge slots to ensure that all cartridges are fully inserted in the slots and that none of the tapes are protruding.
3. Check the tape drives to ensure that they do not contain cartridges.

Important: Never manually insert cartridges in the tape drives.

4. Confirm that the calibration cartridge is installed in slot A50 on the carousel.
5. Confirm that at least one cleaning cartridge is installed in slots A46–A49 on the carousel.
6. Close the door.
7. Confirm that the I/O ports are closed.

13.2 Scanning and Calibrating the Fiducials

Important: A fiducial scan is only required if performing an upgrade to the library. Upgrades include the addition of drive bays, I/O Ports, and/or expansion modules (MEM or POD) to the library. **Installation of single LRM units do not require a Fiducial scan.**

Once you have installed the cartridges, you are ready to scan and calibrate the location of each I/O port, cartridge slot, and tape drive. When you perform a *fiducial scan*, the XLS moves the handler to each cartridge magazine and I/O port and attempts to locate the fiducial targets, shown in [Figure 13-1](#).



Figure 13-1 Cartridge magazine with two fiducials

It also inserts the calibration cartridge, stored in slot A50, into each tape drive to precisely locate the tape drive's position.

To scan and calibrate the fiducials, follow these steps:

1. If necessary, apply power to the library and log in to X-Link. See [Section 9.2 on page 9-3](#).
2. If necessary, press the **Home** button in the upper right corner of any page to return to the Home page.

- From the Home page, select **Service View** to display the Service portlet, shown in [Figure 13-2](#).

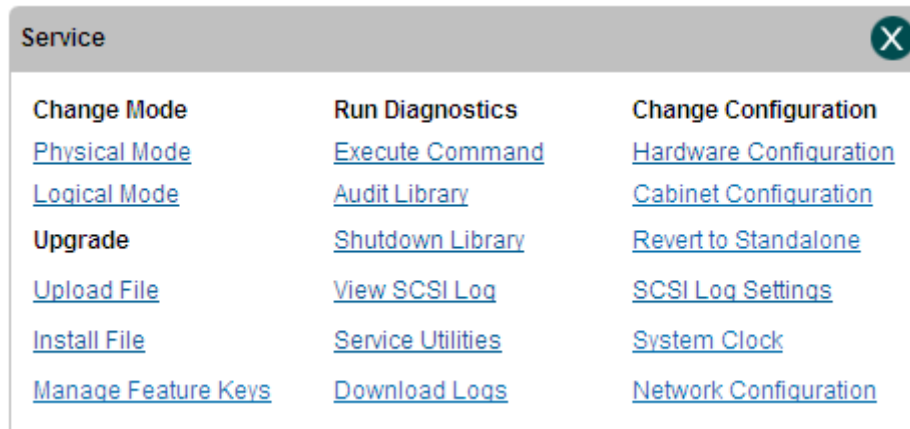

Figure 13-2 Service portlet

- From the Change Configuration section of the Service portlet, select **Hardware Configuration**. The Hardware Configuration page opens, as shown in [Figure 13-4 on page 13-4](#).
- If the Enter Service Password screen appears (see [Figure 13-3](#)), enter the appropriate password and select Save Changes. If the password is not known or after entering the password it does not allow the Hardware Configuration page to open please contact Qualstar Technical Support for assistance.

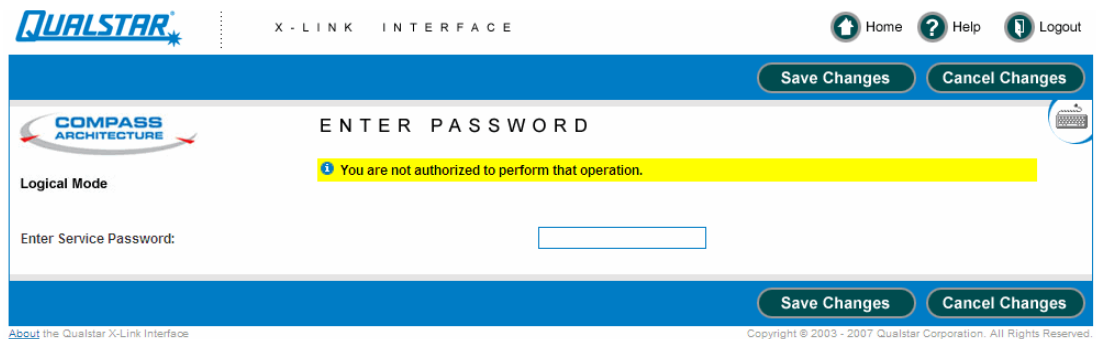

Figure 13-3 Enter Service Password

Figure 13-4 Hardware Configuration page

6. If **Logical Mode** is displayed at the top of the page, select **Go to Physical Mode** from the Misc section to put the XLS into physical mode.
7. From the Fiducials section of the page, select **Home Robot** to home the robot on all axes.
8. Select **I/O Ports** from the Fiducials section of the page to scan the fiducials on the I/O ports. Then, wait while the handler moves to and scans each I/O port position.

Note: During the I/O port scan, the handler also scans the barcode label on any cartridges it finds in the I/O ports.

9. When the I/O port scan has completed, select **All Slots** from the Fiducials section of the page. Then, wait while the handler moves to and scans the fiducials on all magazine slots (except the ones in the I/O ports).

Important: Depending on the number of magazines in your library, scanning all slots can take several hours.

10. When the magazine slot scan has completed, select **Tape Drives** from the Fiducials section of the page. Then, wait while the handler moves the calibration cartridge from slot A50 and inserts it into each tape drive.
11. When the tape drive calibration has completed, select **Dump Database** from the Fiducials section of the page. The results page indicates which, if any, fiducials remain unscanned. See [Figure 13-5](#).

```

Diagnostic Command Results

      running /xls/bin/xlsinit_checkFidbScanned -i -d
Sent MsgId ( LIM_WRITEDB_REQ ):
limMsgWriteDB -----
dest id : 61 XLSBOOT
msgID   : 4006 (LIM_WRITEDB_RSP)
src id  : 4 INV
src base: 0
len     : 130
transC  : 56
transL  : 56
time    : Mon Nov 20 15:07:28 2006

status  : 0
srcbase : 0
seq     : 40285
priority: 0
dbId    : 5
status  : 0
outfilename: /xls/tmp/fidbdump.out

=====
Following fiducial entries are unscanned

Drive : 1011,001B00C01011,0x00000000,30106,1833,0,0,0,14971,0,199,0
Drive : 1013,001B00C01013,0x00000000,16751,1833,0,0,0,14971,0,200,0
Drive : 1014,001B00C01014,0x00000000,10084,1833,0,0,0,14971,0,199,0
Drive : 1022,001B00C01022,0x00000000,23438,7333,0,0,0,14971,0,199,0
Drive : 1023,001B00C01023,0x00000000,16771,7333,0,0,0,14971,0,199,0
Drive : 1024,001B00C01024,0x00000000,10098,7333,0,0,0,14971,0,199,0

----- Total unscanned fiducials = 6

```

Figure 13-5 Results from Dump Fiducial Database option showing unscanned tape drives

12. If any of the fiducials display as unscanned, select the appropriate option as follows:
 - If magazine slots are unscanned, select **Unscanned Slots**
 - If I/O port slots are unscanned, select **I/O Ports**.
 - If tape drives are unscanned (as in the example above), select **Tape Drives**.
13. After all locations have been scanned, select **Calibrate All** to calculate the positions of the fiducials.

14. Refer to [Section 13.3 on page 13-6](#) for instructions for scanning the inventory and locking the doors.

13.3 Scanning the Inventory and Locking the Doors

After scanning the fiducials, you can scan the barcode labels on any cartridges installed in the slots to establish the library's inventory. To scan the inventory, follow these steps:

1. Access the View/Edit Hardware Configuration page as described in [Section 13.2 on page 13-2](#).
2. Select **Scan Inventory** from the Inventory section of the page.

Important: Depending on the number of magazines in your library, scanning all slots can take several hours.

3. Wait while the handler scans the barcode label on each cartridge, then select **Sync Inventory** to update the logical library inventories with the results of the physical library scan.
4. From the Misc section of the page, select **Lock Doors**. The Lock Doors page opens, as shown in [Figure 13-6](#).

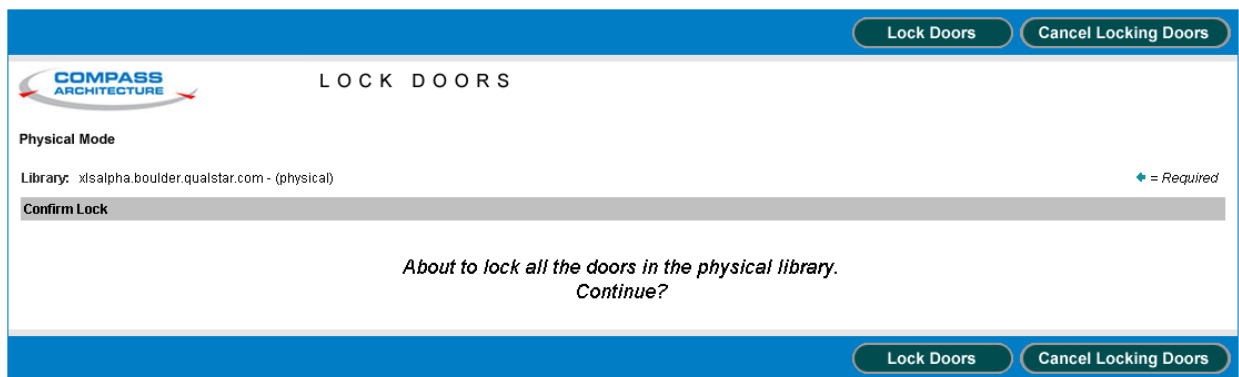

Figure 13-6 Lock Doors page

5. Press **Lock Doors**. The library performs the following actions:
 - It engages the solenoids controlling the electronic door locks.
 - It stops flashing the yellow Attention LED.

Note: If one or more I/O ports are open, the LED remains on but does not flash.

- If any of the light curtain sensors have been violated, it rescans the cartridges in the affected areas.

6. Refer to [Section 11.3, “Viewing the Inventory Report,” on page 11-11](#) to generate a new report of cartridges for each logical library. You can compare this report to the previous one to confirm that the cartridges were installed correctly.

Notes:

This chapter provides instructions for the following tasks:

- Putting the XLS in logical mode. See [Section 14.1](#).
- Bringing the logical libraries online and starting the software applications. See [Section 14.2 on page 14-2](#).
- Ensuring that the installation was successful and that all XLS components and tape drives are working and communicating correctly. See [Section 14.3 on page 14-3](#).
- Troubleshooting any installation or configuration problems. See [Section 14.4 on page 14-4](#).
- Backing up the configuration files for the physical and logical library definitions that are stored on the XLS's system controller. See [Section 14.5 on page 14-5](#).

14.1 Putting the XLS in Logical Mode

This section provides information about putting the XLS in logical mode in preparation for bringing the logical libraries online. In logical mode, one or more software applications control the library and you interact with X-Link from a logical library perspective.

When you interact with the XLS in logical mode:

- You can view and control only those resources (cartridge slots, tape drives, and I/O ports) that have been assigned to a particular logical library.
- You cannot view or control resources assigned to any other logical library.
- You specify SCSI element addresses for cartridge slots, I/O port slots, and tape drives.
- The logical libraries may be online or offline.

To put the XLS in logical mode, follow these steps:

1. Make sure that any library or MEM doors are closed and locked and that the fiducial and inventory scans have been completed. See [Chapter 13, “Scanning the Fiducials and Inventory.”](#)
2. If necessary, log into X-Link and press the **Home** button in the upper right corner of any page to return to the Home page.

3. Select **Logical Library View** or **Show All** to display the Logical Libraries portlet.
4. Select **Logical Mode** from the physical library section of the Logical Library portlet. The Put into Logical Mode confirmation page opens, as shown in [Figure 14-1](#).

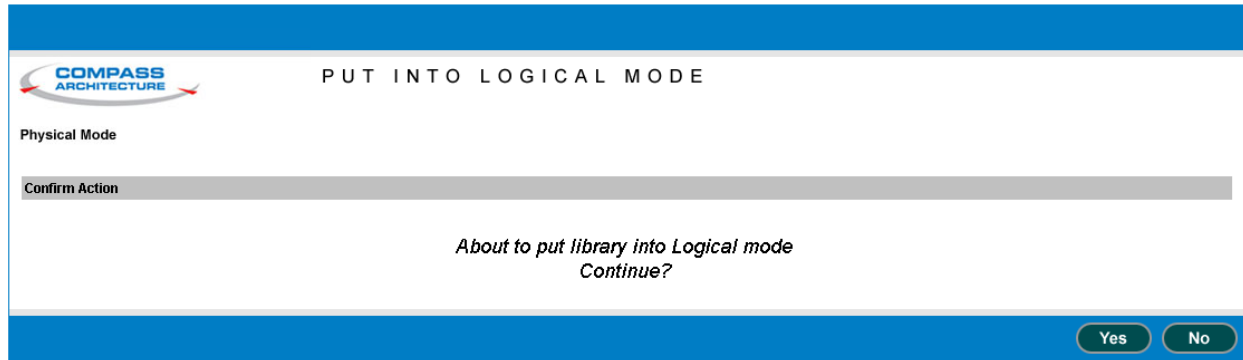

Figure 14-1 Put into Logical Mode confirmation page

5. Press **Yes** to confirm that you want to put the XLS in logical mode.

14.2 Bringing a Logical Library Online

Important: To simplify the process of finding and correcting installation errors, bring the logical libraries online one at a time. Make sure that each logical library is working correctly before bringing any other logical library online.

When you bring a logical library online, the following occurs:

- An event is logged in the event log and a message is sent to designated users.
- All other logical libraries and the tape drives remain in their current states.

To bring a logical library online, follow these steps:

1. If necessary, press the **Home** button in the upper right corner of any page to return to the Home page.
2. Select **Logical Library View** or **Show All** to display the Logical Libraries portlet.

3. Select the radio button to the left of the logical library name, then select **Online Logical Library** from the Administration and Configuration list.

or

In the Status column of the logical libraries table, select **Offline**. (This automatically selects the radio button for the logical library.)

The Bring Library Online page opens, as shown in [Figure 14-2](#).

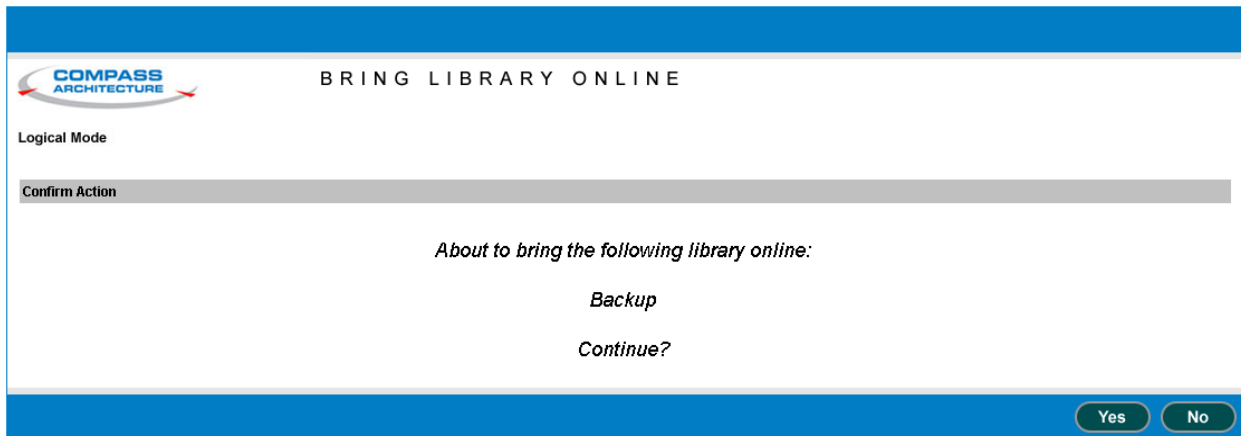

Figure 14-2 Bring Library Online page

4. Press **Yes** to confirm that you want to bring the library online.

14.3 Starting the Application

After bringing the logical library online, start the backup software application and verify the following:

- The software application detects the correct number of cartridge slots, tape drives, and I/O ports.
- The software application detects the correct barcode label information.
- You can use the software application to move the handler to cartridge and tape drive locations associated with the logical library.
- You can use the software application to read and write data.

14.4 Troubleshooting Installation Problems

If your library and application software are not communicating after installation, check the following:

Cabling: Make sure that the HBAs and tape drives are cabled correctly and that all cables are securely connected at both ends. See [Section 8.2 on page 8-1](#).

Termination: Make sure any SCSI buses are properly terminated. The SCSI HBAs provide active termination. See [“Connecting SCSI Cables and Terminators” on page 8-3](#).

Target IDs: If you are using a SCSI HBA and SCSI tape drives, make sure that the target IDs are not the same as the IDs used by other devices on the bus. See [Section 10.5.5 on page 10-29](#).

Important: Each device on the SCSI bus must have a unique target ID. Because it may be connected to multiple buses, the library does not check for duplicate target IDs.

Review the documentation for the software application to determine if there are any special requirements for setting target IDs.

HBA connections: Make sure that the SCSI or Fibre Channel cable is connected to the HBA port you specified when completing the Create Logical Library wizard. See [Section 11.2 on page 11-3](#).

Correct Port IDs and LUNs: Make sure the port IDs and logical unit numbers (LUNs) are defined correctly for the logical library. To confirm the settings, take the logical library offline, then select **View/Edit Nexus** from the Logical Libraries portlet.

Compatibility: Make sure that the library is compatible with the software application and that any software application licenses reflect the correct number of tape drives and cartridge slots. Make sure that the operating mode is set to XLS-8000.

Software installation: Make sure that the software application is installed and configured correctly for use with the library.

Host computer: If you are using a SCSI HBA and tape drives, you may need to restart the host computer in order to recognize the XLS and the tape drives.

If the error persists, contact Qualstar Technical Support for assistance.

14.5 Downloading the Library Configuration

Once the physical and logical libraries have been configured and are running correctly, copy the configuration file, which is stored on the XLS's system controller, to the network or to a standalone computer. You will need this file if the system controller fails or if you want to return to your initial configuration. (See the *XLS Technical Service Manual* for instructions.)

CAUTION

Whenever you make changes to the system configuration, be sure to download and save the new configuration file.

To download a copy of the configuration file, follow these steps:

1. If necessary, press the **Home** button in the upper right corner of any page to return to the Home page.
2. Select **Administrator View** or **Show All** to display the Configuration portlet, shown in [Figure 14-3](#).



Figure 14-3 Configuration portlet

- From the Configuration portlet, select **Manage Configurations**. The Manage Configurations page opens, as shown in [Figure 14-4](#), indicating which configuration files are ready to be downloaded.

The screenshot shows the 'MANAGE CONFIGURATIONS' page. At the top right are 'Refresh' and 'Done' buttons. The Compass Architecture logo is on the left. Below the title, there are sections for 'Logical Mode', 'Create new configuration backup', and 'Upload a configuration archive'. The 'Create new configuration backup' section has a 'Name' field with the value 'xls_1002264_2010-02-22_07-42-17' and a 'Label' field. To the right are 'Yes', 'Mount', and 'Unmount' buttons, with a 'USB Flash Not Mounted' status. The 'Upload a configuration archive' section has a 'Browse...' button and a 'Yes' button. Below these is a table of configurations.

Configuration	Label	Size	Last Modified	Archive Date	Action
xls_0910244_Auto_A	Weekly backup: Wed, Feb 10, 07:05 AM	184685	2010/02/10 07:05:03	2010/02/22 07:40:42	view download restore delete
xls_0910244_Auto_B	Weekly backup: Wed, Feb 03, 07:05 AM	182695	2010/02/03 07:05:03	2010/02/03 07:05:09	view download restore delete
xls_0910244_Auto_C	Weekly backup: Wed, Jan 27, 07:05 AM	182222	2010/01/27 07:05:02	2010/01/27 07:05:11	view download restore delete
xls_0910244_Auto_B	Weekly backup: Wed, Feb 03, 07:05 AM	182695	2010/02/03 07:05:03	2010/02/03 07:05:09	view download restore delete
xls_0910244_Auto_C	Weekly backup: Wed, Jan 27, 07:05 AM	182222	2010/01/27 07:05:02	2010/01/27 07:05:11	view download restore delete
xls_0910244_2009-10-20_12-13-34	No Label	178514	2009/10/20 12:13:50	2009/10/20 14:52:49	view download restore delete
xls_1234567_2009-10-19_16-03-13	No Label	178688	2009/10/19 16:03:26	2009/10/19 16:03:38	view download restore delete

Figure 14-4 Manage Configurations page

4. Select the desired configuration and Press **download** in the Action column. A File Download window similar to the one shown in [Figure 14-5](#) opens, allowing you to save or open the configuration file **xls_0910244_Auto_A.tar.gz**.

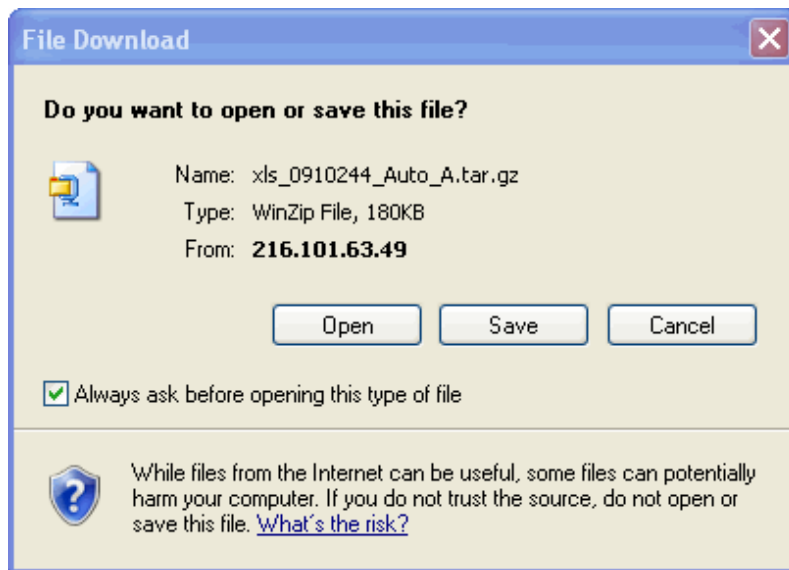

Figure 14-5 Example of a download window

5. Press **Save**. A window similar to the one in [Figure 14-6](#) opens, allowing you to specify a destination for the configuration file.

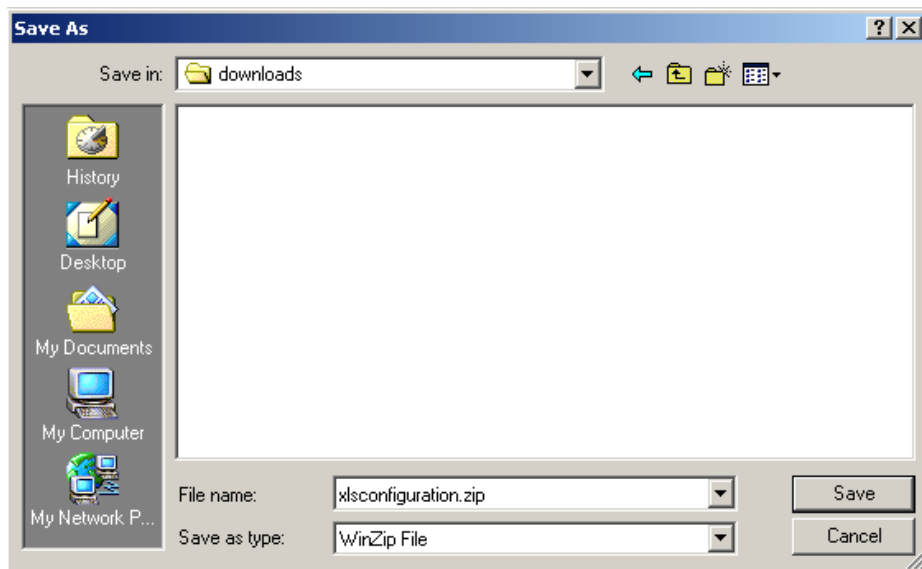

Figure 14-6 Example of a Save As window

6. Specify a destination folder for the configuration file and press **Save**.

7. When you have successfully downloaded the configuration file, press **Done** to return to the Home page.
8. Make a backup copy of the downloaded file and save it in a secure location.

Important: Refer to the *XLS Library Technical Service Manual* for instructions for using the downloaded file to restore the library's configuration.

Appendix A

Library Addresses

This appendix lists physical addresses for every possible cartridge slot or tape drive location in the XLS-810160 or XLS-810240.

You may need to know the library's physical addresses when you install the tape drives and cartridges and when you perform various operations on the physical library. These physical addresses are fixed and cannot be changed. In this way, they differ from the SCSI element addresses for a logical library, which are assigned when the logical libraries are created.

To determine the physical address for a particular cartridge slot or tape drive within the physical library, refer to the figures listed in [Table A-1](#):

Model	For physical addresses of...	Refer to...
XLS-810160	The carousel and the drive bays	Figure A-1 on page A-2
XLS-810240	The carousel and the drive bays	Figure A-2 on page A-3
All Models	The tape drives as viewed from the back	Figure A-3 on page A-4
	The slots in an expansion pod	Figure A-4 on page A-5
	The I/O port slots	Figure A-5 on page A-6
	The fixed port slots	Figure A-6 on page A-6
MEM	The cartridge slots on the carousel (XLS-85000)	Figure A-7 on page A-7

Table A-1 Physical addresses for the XLS

A.1 Addresses for the the XLS-810160/810240

Figure A-1 shows the physical addresses for the carousel of the XLS-810160 and a detailed view of five drive bays installed. The slots shaded in gray are not available for use unless the LRM is upgraded to an XLS-810240. This figure shows the fixed address for each tape drive position as viewed from the front.

Note: Slot A50 in the carousel is reserved for the calibration cartridge, and slots A46–A49 are reserved for the cleaning cartridges used by the physical library.

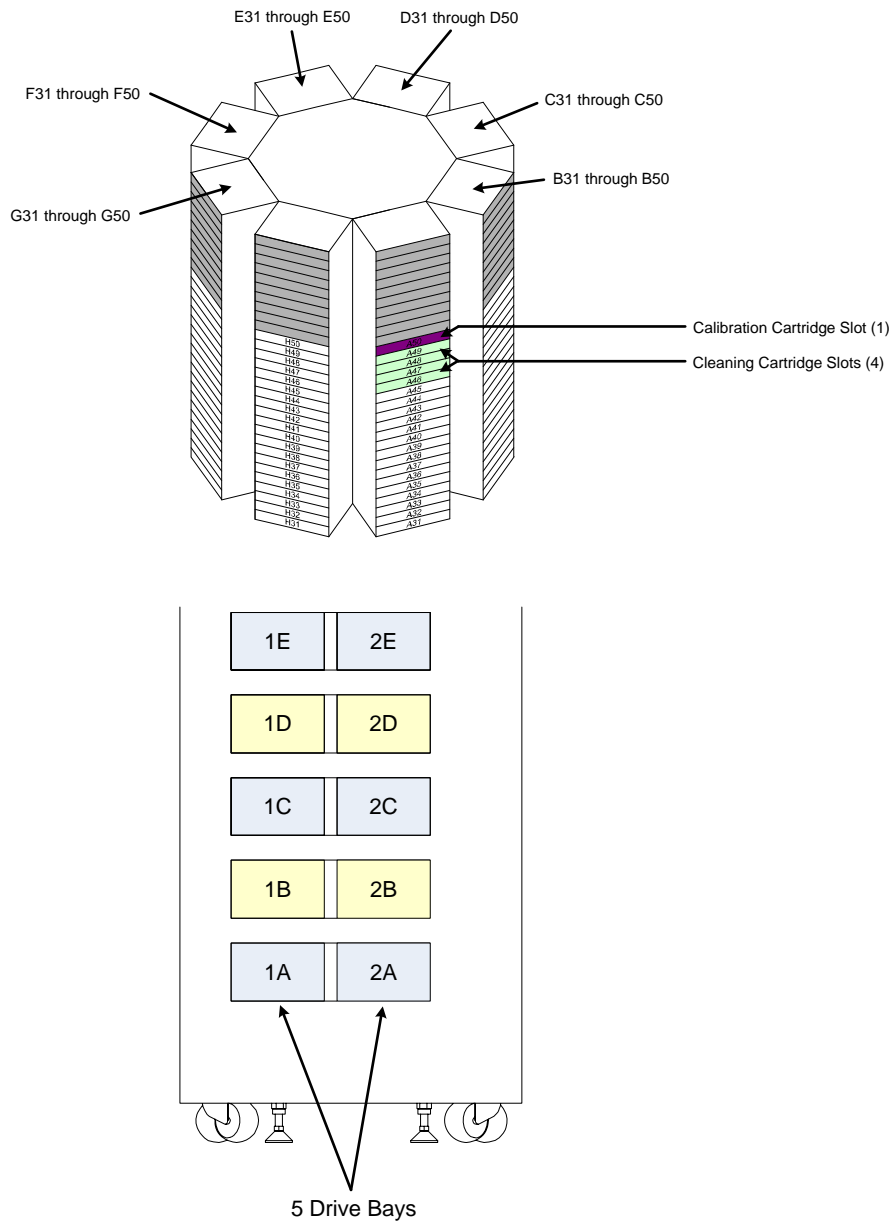

Figure A-1 Physical addresses for the carousel of the XLS-810160 and 5 drive bays installed in positions 1A–2E (view from the front)

Figure A-2 shows the physical addresses for the carousel of the XLS-810240 and a detailed view of five drive bays installed. This figure shows the fixed address for each tape drive position as viewed from the front.

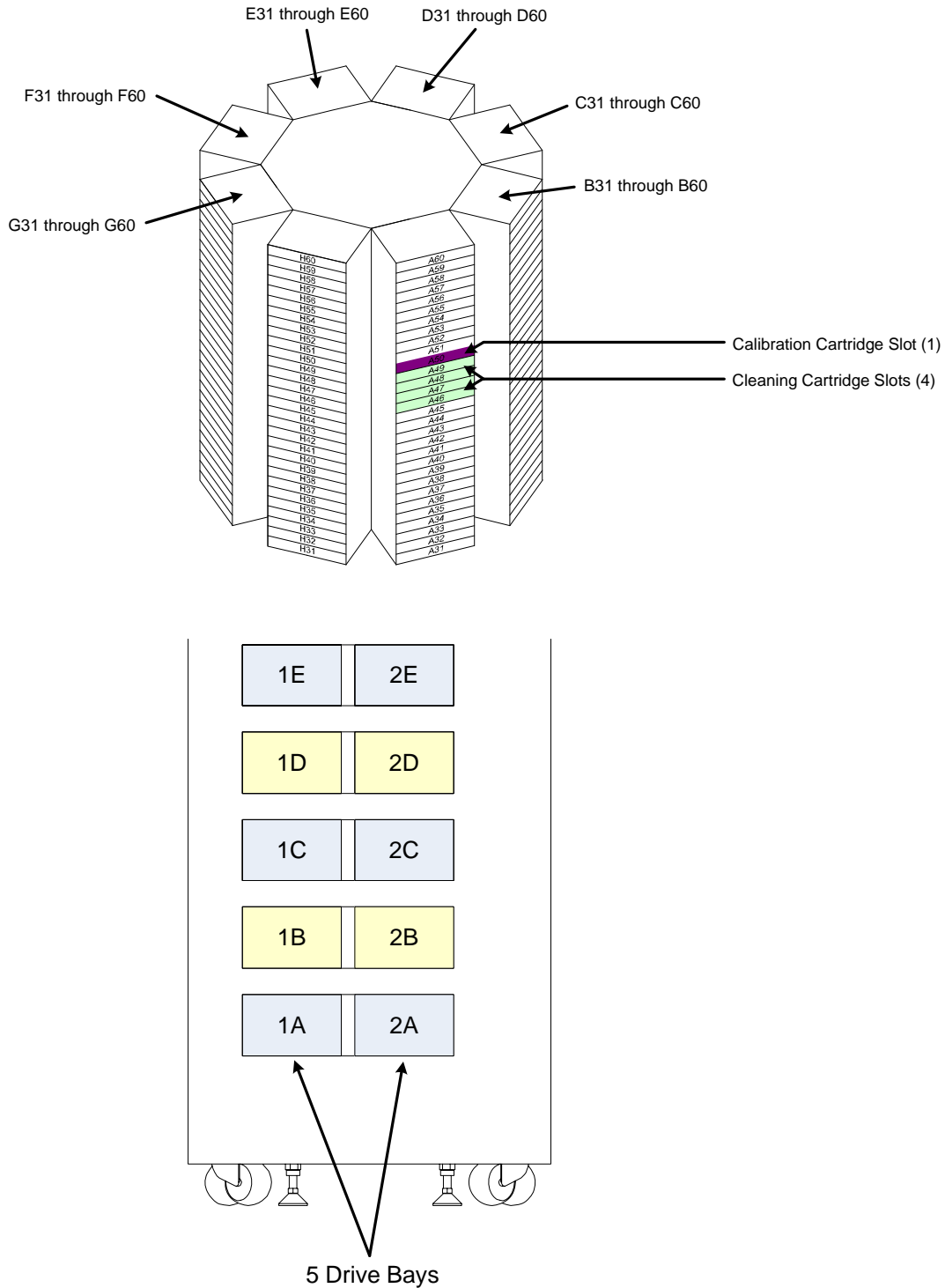

Figure A-2 Physical addresses for the carousel of the XLS-810240 and 5 drive bays installed in positions 1A-2E (view from the front)

Figure A-3 shows the physical addresses of the tape drives in the XLS-810160/810240, as viewed from the back.

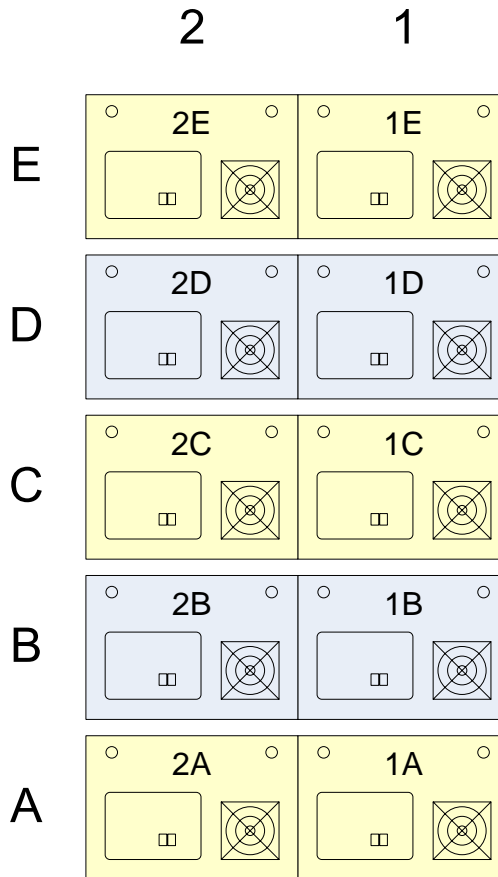

Figure A-3 Physical addresses for the tape drives in the XLS-810160/810240, as viewed from the back

A.2 Addresses for Expansion Pod, I/O Ports, and Fixed Port Slots

[Figure A-4](#) shows the physical addresses for the cartridge slots in an XLS-810160/810240 expansion pod.

Expansion Pod

B60	A60
B59	A59
B58	A58
B57	A57
B56	A56
B55	A55
B54	A54
B53	A53
B52	A52
B51	A51
B50	A50
B49	A49
B48	A48
B47	A47
B46	A46
B45	A45
B44	A44
B43	A43
B42	A42
B41	A41
B40	A40
B39	A39
B38	A38
B37	A37
B36	A36
B35	A35
B34	A34
B33	A33
B32	A32
B31	A31
B30	A30
B29	A29
B28	A28
B27	A27
B26	A26
B25	A25
B24	A24
B23	A23
B22	A22
B21	A21
B20	A20
B19	A19
B18	A18
B17	A17
B16	A16
B15	A15
B14	A14
B13	A13
B12	A12
B11	A11
B10	A10
B09	A09
B08	A08
B07	A07
B06	A06
B05	A05
B04	A04
B03	A03

Figure A-4 Physical addresses for the slots in a XLS-810160/810240 expansion pod

[Figure A-5](#) shows the physical addresses for both possible I/O port slots. The XLS-810160/810240 always has one I/O port on the right. .

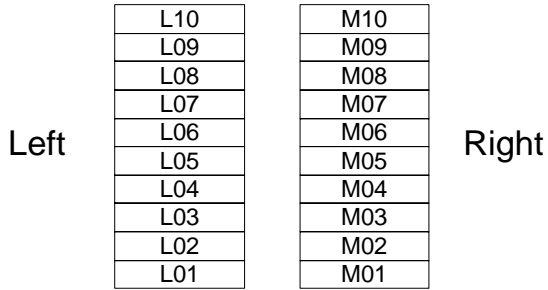

Figure A-5 Physical addresses for the I/O port slots, if installed (view from the front)

[Figure A-6](#) shows the physical addresses for the 10 fixed port slots. The XLS-810160/810240 always has one I/O port on the right..

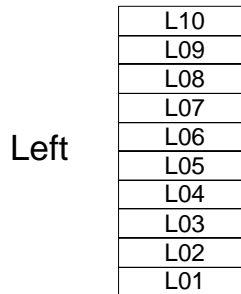

Figure A-6 Physical addresses for the fixed port slots (view from the front)

A.3 Addresses for the Media Expansion Module (MEM)

[Figure A-7](#) shows the physical addresses for the cartridge slots on the carousel in the Media Expansion Module (MEM). The five slots A46–A50 are reserved for pass through.

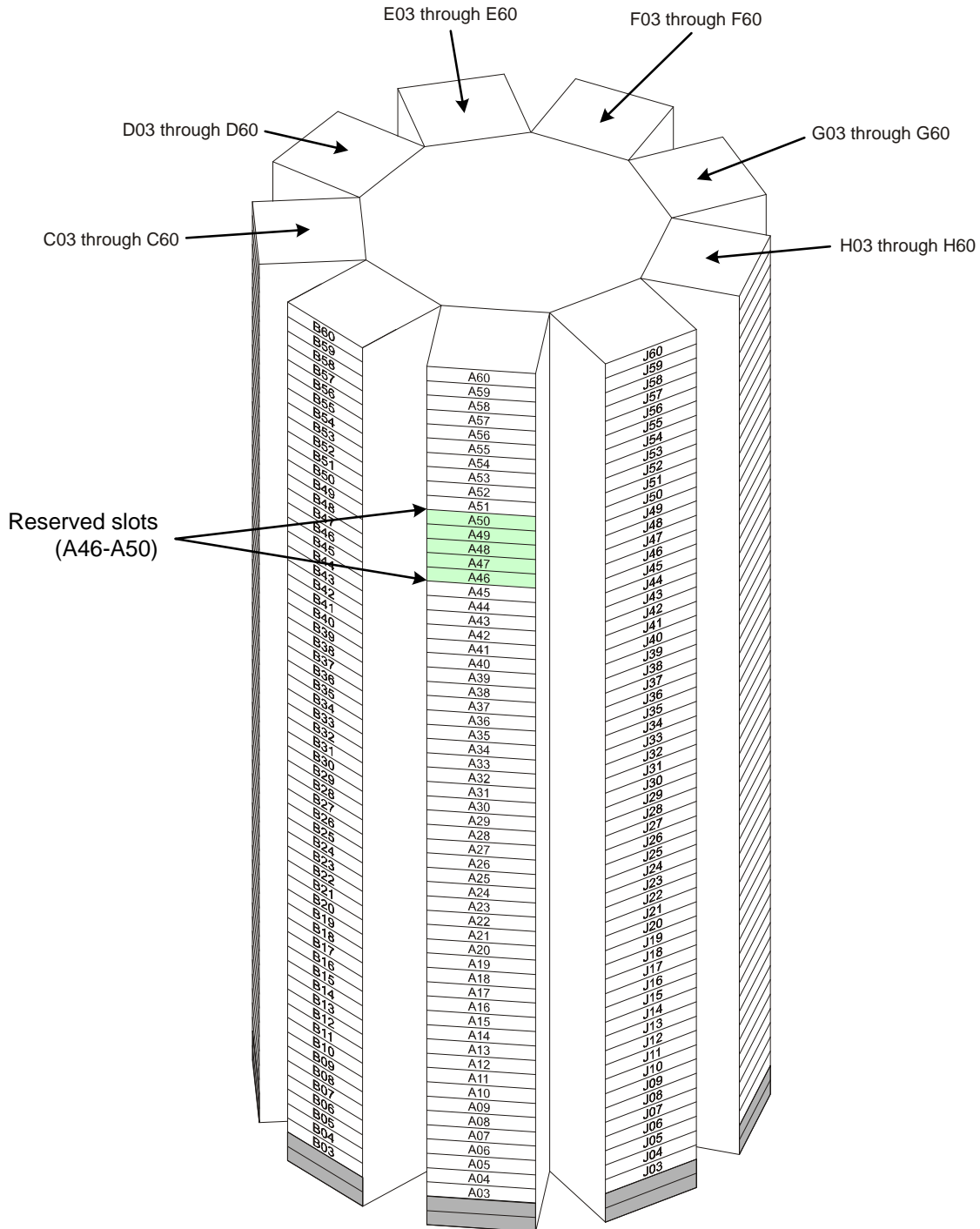

Figure A-7 Physical addresses for the slots in an XLS-85000 Media Expansion Module

Notes:

Glossary

alert	A notification sent to specified users when an event occurs in the library.
barcode reader	The device on the library's robotic handler that scans and reads barcode labels on the cartridges.
calibration cartridge	A special cartridge containing a triangular target (<i>fiducial</i>) that is inserted into each tape drive during the calibration process.
carousel	The rotating mechanism in a LRM or Media Expansion Module (MEM) that holds the cartridges.
cartridge inventory	The internal data base of cartridge locations that is maintained by the system controller.
cartridge slot	Any of the locations in the library that can store a cartridge. A cartridge slot is referred to as a storage element in the SCSI standard.
drive bay	The removable hardware in the library that can contain up to two tape drives
drive carrier	The hardware that encloses the tape drives and provides power, SCSI or Fibre Channel connectors, communications with the system controller, status LEDs, and cooling fans.
elements	The addressable locations in the library, including the tape drives, the cartridge slots, the handler, and the I/O ports slots.
EMI	Electro magnetic interference.
Ethernet	A local area networking technology. Ethernet can transport any of several upper layer protocols, the most popular of which is TCP/IP.
event	A change of condition to a library component or a change of state that can be recorded in the event log. When an event occurs, an e-mail or pager alert can be sent to specified users.

facet	One of the columns of cartridge slots in a Media Expansion Module (MEM2). The carousel in a MEM contains 9 facets, with 58 slots (rows) per facet.
Fibre Channel	One of the communication protocols supported by the library. Fibre Channel is a set of standards for a serial I/O bus.
front panel slot	Any the cartridge slots that can be installed on the inside of the library's front panel instead of an I/O port.
handler	The library assembly that includes the picker mechanism and the barcode reader. The handler moves side to side on the X-axis, up and down on the Y-axis, and in and out on the Z-axis. It rotates on the Theta-axis. The handler is referred to as a medium transport element in the SCSI standard.
HBA	Host bus adapter card.
host bus adapter card (HBA)	A circuit board installed in one of the system controller's four expansion slots that allows the library to attach to and communicate with a SCSI bus or Fibre Channel network. The HBAs supported by the library have two ports, which means you can connect two networks or SCSI buses to each card.
hot swappable	A library component, such as tape drive assemblies, fans, and power supplies, that can be replaced without removing system power.
I/O port	An opening on the front of the library through which cartridges can be inserted or removed without exposing internal library components.
Inventory Sentry	The pairs of LED emitters and detectors in the front of the library that detect whether a cartridge is protruding from a slot or whether someone has reached into the library. Also referred to as the <i>light curtain</i> .
LED	Light emitting diode. The library contains five LEDs on its front panel to indicate its operating status. Additional LEDs are used on each power supply and tape drive assembly.
library	A robotic media handler that is capable of storing multiple pieces of removable media and loading and unloading them from one or more tape drives in arbitrary order.
Library Resource Module (LRM)	The main library module that contains the system controller, touch screen, status LEDs, power/PC bay, handler, tape drives, I/O ports and cartridge slots.
light curtain	See <i>Inventory Sentry</i> .

logical library	One of up to eight partitions of the physical library. Logical libraries ensure that each software application has dedicated and secure access to specific tape drives, cartridge slots, and I/O ports. The handler is shared among all logical libraries.
LRM	Library Resource Module. The XLS base unit.
LTO	Linear Tape Open. An industry standard 1/2-inch tape format also known as Ultrium.
LUN	Logical unit number. A number between 0 and 7 assigned to each logical library.
Management Information Base (MIB)	The specification and formal description of a set of objects and variables that can be read and possibly written using the SNMP protocol.
Media Expansion Module (MEM)	The auxiliary library module that contains a motor-driven carousel with storage for 517 cartridges. You can connect one MEM to each LRM.
medium changer	The library's SCSI controller. The medium changer responds to SCSI commands sent by initiators (or host applications) and sends instructions to the system controller to move cartridges between tape drives, cartridge slots, and I/O ports.
MEM	Media Expansion Module. The XLS expansion unit that contains a carousel.
MIB	Management Information Base.
nexus setting	A unique combination of port ID, target (or SCSI) ID, and logical unit number (LUN) that describes each logical library connection.
parallel SCSI	One of the communication protocols supported by the library. The parallel SCSI protocol defines the rules and processes for transmitting and receiving data over a parallel (multi-signal) I/O bus.
physical library	The entire library, including all tape drives, cartridge slots, the robotics, and the I/O ports.
portlet	One of the following sections on the Home page: Configuration, Events, Logical Libraries, Physical Library, Settings & Policies, Users & Groups, and Service. The portlets on the Home page can be rearranged or closed to suit the needs of each user.
PC bay	The library assembly that contains the system controller, two cooling fans, the AC power switch, and the AC power connector.

robotics	Any part of the library that moves automatically, including the carousel, the gripper, the I/O ports, and the handler.
SCSI	Small Computer System Interface.
Simple Mail Transfer Protocol (SMTP)	A protocol for sending e-mail messages between servers and between a mail client and a mail server.
Simple Network Management Protocol (SNMP)	A protocol for monitoring and managing systems and devices in a network. The data being monitored and managed is defined by a MIB. The functions supported by the protocol are the request and retrieval of data and the setting or writing of data.
SMTP	Simple Mail Transfer Protocol.
SNMP	Simple Network Management Protocol.
stylus	A pen shaped instrument that can be used when inputting data or accessing menus on the libraries touch-screen display.
system controller	The PC within the library that manages and controls all library activities.
tape drive	The devices used to write and read data. Tape drives are mounted in drive carriers. Tape drives are referred to as data transfer elements in the SCSI standard.
tape drive assembly	The tape drive plus the drive carrier. Tape drive assemblies are installed into the drive bays.
touch screen	The 15-inch color page on the library's front panel used to display X-Link.
user group	A collection of library users that has been assigned a common set of permissions.
virtual keyboard	A feature of the library's touch-screen display that allows you to enter text without needing a real keyboard.
X-Link	The XLS Management Interface.

Index

#

10/100 BaseT Ethernet network [10-2](#)

A

Activity LED [9-10](#)

addresses

logical library [11-11](#)

physical library [5-1](#), [6-1](#), [A-1](#)

administrator

changing password [10-27](#)

logical library [11-9](#)

administrator information

physical library [10-26](#)

air filters

change policy [10-37](#)

alert

check air filter [10-38](#)

defined [GL-1](#)

Event Severity to Email [10-39](#)

Event Severity to Page [10-39](#)

Attention LED [9-9](#)

B

barcode label requirements [1-11](#)

barcode labels

applying [12-5](#)

barcode reader

defined [GL-1](#)

described [1-10](#)

C

cables

connecting SCSI [8-3](#)

EMI shield [8-2](#)

Ethernet [10-3](#)

Fibre Channel [8-5](#)

calibration

defined [1-11](#)

calibration cartridge

defined [GL-1](#)

installing [12-1](#)

location [A-2](#)

when used [1-11](#)

carousel

addresses [A-5](#), [A-7](#)

defined [GL-1](#)

cartridge bays

addresses [A-2](#)

cartridge inventory

defined [GL-1](#)

scanning [1-11](#)

cartridges

barcode labels [12-5](#)

calibration [12-1](#)

cleaning [12-1](#)

handling precautions [12-3](#)

installing [12-5](#)

cartridge slots

addresses [5-1](#), [6-1](#), [11-11](#), [A-1](#)

assigning to logical library [11-8](#)

defined [GL-1](#)

installing cartridges [12-5](#)

reserved slots [12-1](#), [A-2](#)

types of [1-15](#)

caution notices [1-19](#)

cleaning cartridges

reserved slots [12-1](#)

cleaning cartridge slots [A-2](#)

configuration

saving [14-5](#)

contact information

logical library [11-10](#)

physical library [10-25](#)

cover

blank drive [7-2](#)

Create Logical Library wizard [11-3](#)

CSV, exporting data to [11-12](#)

D

data cartridges

See also cartridges

default

administrator ID [9-13](#)

IP address for service port [10-4](#)

session timeout value [10-38](#)

deleting

events [10-36](#)

documents, related [1-20](#)

domain name system (DNS) [10-3](#)

doors

described [1-15](#)

door slots

addresses [A-2](#)

drive bays

addresses [A-3](#), [A-4](#)

defined [GL-1](#)

described [1-13](#)

drive carriers

defined [GL-1](#)

described [1-12](#)

LEDs [9-9](#)

drive filler assembly [7-2](#), [7-12](#)

dynamic host configuration protocol (DHCP)

server [10-3](#)

E

elements

defined [GL-1](#)

e-mail settings [10-34](#)

EMI [GL-1](#)

EMI shield

removing [8-2](#)

Ethernet

connecting to [10-1](#)

defined [GL-1](#)

IP address [10-4](#)

event

defined [GL-1](#)

deleting [10-36](#)

event log

settings [10-36](#)

Event Severity to Email field [10-39](#)

Event Severity to Page field [10-39](#)

Excel, exporting data to [11-12](#)

exporting XLS information [11-12](#)

F

Fault LED [9-9](#), [9-11](#)

Fibre Channel

connecting cables [8-5](#)

defined [GL-2](#)

drive carrier LEDs [9-9](#)

example cabling diagram [7-5](#), [7-7](#)

fiducial

described [1-10](#)

fiducial scan [1-11](#)

fixed port assembly

addresses [A-6](#)

described [1-14](#)

physical addresses [A-5](#)

front panel cartridge slots

defined [GL-2](#)

G

gripper assembly

axes [1-10](#)

H

handler

defined [GL-2](#)

X-axis hard stop [5-3](#), [6-7](#)

Home page

Logical Libraries portlet [11-3](#)

Settings & Policies portlet [10-33](#)

host bus adapters (HBAs)

connecting [8-4](#), [8-6](#)

defined [GL-2](#)

port IDs [8-5](#), [11-8](#)

specifying for logical library [11-8](#)

hot swappable [GL-2](#)

I

I/O port

addresses [A-6](#)

assigning to logical library [11-8](#)

defined [GL-2](#)

described [1-14](#)

physical addresses [A-5](#)

IDs

for HBA ports [8-5](#), [11-8](#)

tape drive target [10-31](#)

- inspection instructions [3-1](#)
- installation
 - cartridges [12-1](#), [13-1](#)
 - configuring physical library [10-1](#)
 - connecting to Ethernet [10-1](#)
 - creating logical library [11-1](#)
 - example cabling diagrams [7-3](#)
 - overview of steps [2-2](#)
 - parts check list [2-4](#)
 - saving configuration [14-5](#)
 - tape drives [7-1](#)
 - testing [14-1](#)
 - troubleshooting [14-4](#)
- Internet browsers
 - supported [10-2](#)
- Internet Explorer [10-2](#)
- inventory report [11-11](#)
- inventory scan
 - described [1-11](#)
- Inventory Sentry
 - defined [GL-2](#)
- IP address
 - editing [10-24](#)
 - service port [10-4](#)
- L**
- LEDs
 - defined [GL-2](#)
 - drive carrier [9-9](#)
 - front panel [9-9](#)
 - power supply [9-10](#)
- library
 - See also* logical library
 - See also* physical library
 - defined [GL-2](#)
 - powering on [9-1](#)
- Library Activity LED [9-9](#)
- Library Resource Module (LRM) [1-1](#)
 - components and features [1-4](#)
 - defined [GL-2](#)
 - described [1-4](#)
 - LEDs [9-9](#)
- light curtain [1-15](#)
 - defined [GL-2](#)
- Link LED [9-10](#)
- logging out
 - policy for idle users [10-37](#)
- logical library
 - administrator [11-9](#)
 - assigning resources [11-8](#)
 - bringing online [14-1](#)
 - cartridge slots [11-8](#)
 - connected to multiple host computers [7-9](#)
 - contacts [11-10](#)
 - creating [11-1](#)
 - defined [11-1](#), [GL-3](#)
 - example [11-1](#)
 - HBA [11-8](#)
 - I/O ports [11-8](#)
 - logical unit number (LUN) [11-8](#)
 - physical addresses [11-11](#)
 - saving configuration [14-5](#)
 - tape drives [7-2](#), [11-8](#)
 - testing [14-1](#)
- logical unit number (LUN)
 - assigning [11-8](#)
 - defined [GL-3](#)
- LRM. *See* Library Resource Module (LRM)
- LTO [GL-3](#)
- M**
- Management Information Base (MIB) [GL-3](#)
- media. *See* cartridges
- Media Expansion Module (MEM) [1-1](#)
 - addresses [A-5](#), [A-7](#)
 - defined [GL-3](#)
 - physical addresses [A-7](#)
 - side panel [5-11](#), [6-11](#)
- medium changer
 - defined [GL-3](#)
 - operating mode [11-7](#)
- Mozilla Firefox [10-2](#)
- Mozilla Suite [10-2](#)
- N**
- Netscape [10-2](#)
- Network Activity LED [9-9](#)
- network information [10-23](#)
- O**
- online operations
 - logical library [14-1](#)
 - software application [14-3](#)

P

packing materials [3-14](#)
parallel SCSI
 See SCSI
password
 system administrator [10-27](#)
physical library
 addresses [5-1](#), [6-1](#), [A-1](#)
 administrator information [10-26](#)
 configuring [10-1](#)
 contact information [10-25](#)
 defined [10-1](#), [11-1](#), [GL-3](#)
 event log [10-36](#)
 network information [10-23](#)
 saving configuration [14-5](#)
 SNMP settings [10-36](#)
policies for physical library [10-37](#)
port IDs [8-5](#), [11-8](#)
portlet
 Settings & Policies [10-33](#)
portlets
 Configuration [10-23](#), [10-30](#), [14-5](#)
 defined [GL-3](#)
 Settings & Policies [10-33](#)
power/PC bay [1-5](#)
power connector [9-3](#)
powering on
 library [9-1](#)
power supplies
 LEDs [9-10](#)
power switch [9-3](#)
PWR Good LED [9-11](#)

Q

Qualstar, contacting [1-23](#)

R

rear wall slots
 physical addresses [A-2](#)
relative humidity
 cartridges [12-4](#)
reserved cartridge slots
 addresses [A-2](#)
 installing cartridges [12-1](#)
Robot Activity LED [9-9](#)
robotics [GL-4](#)

S

safety notices [1-19](#)
saving configuration [14-5](#)
SCSI
 connecting cables and terminators [8-3](#)
 defined [GL-4](#)
 example cabling diagram [7-3](#), [7-4](#), [7-7](#)
service port
 connecting to [10-1](#)
 IP address [10-4](#)
session timeout
 value [10-38](#)
Settings & Policies portlet [10-33](#)
Simple Mail Transfer Protocol (SMTP)
 defined [GL-4](#)
Simple Network Management Protocol (SNMP)
 defined [GL-4](#)
 settings for physical library [10-36](#)
SMTP
 See Simple Mail Transfer Protocol
SNMP
 See Simple Network Management Protocol
software applications
 bringing online [14-3](#)
 testing [14-3](#)
status LEDs [9-8](#)
stylus [9-12](#)
 defined [GL-4](#)
system controller [1-6](#)
 defined [GL-4](#)

T

tape drives
 addresses [A-3](#), [A-4](#)
 assigning to logical library [11-8](#)
 defined [GL-4](#)
 drive filler assembly [7-2](#)
 guidelines for installation [7-2](#)
 installing [7-1](#), [7-12](#)
 target IDs [10-31](#)
tapes. *See* cartridges
target IDs
 tape drives [10-31](#)
temperature
 cartridges [12-4](#)
terminators
 connecting [8-3](#)
testing
 installation [14-1](#)

- logical library [14-1](#)
- software applications [14-3](#)
- Theta-axis [1-10](#)
- timeout value [10-38](#)
- Tip (N) Tell indicator [3-2](#)
- touch screen
 - defined [GL-4](#)
 - described [1-8](#)
 - logging in [9-12](#)
- troubleshooting
 - installation problems [14-4](#)
- typographic conventions [1-18](#)

U

- unpacking instructions [3-3](#)
- user
 - logging off when idle [10-37](#)
- user group
 - defined [GL-4](#)
- user ID
 - default system administrator [9-13](#)

V

- virtual keyboard [9-12](#), [GL-4](#)

W

- warning notices [1-19](#)
- wizard
 - Create Logical Library [11-3](#)

X

- X-axis [1-10](#)
- X-axis hard stop [5-3](#), [6-7](#)
- X-Link
 - described [1-8](#)
- XLS-832700
 - cartridge slot locations [1-15](#)
 - physical addresses [A-2](#)
- XML, exporting data to [11-12](#)

Y

- Y-axis [1-10](#)

Z

- Z-axis [1-10](#)

