



Q24™ and Q48™ Tape Library

Installation and Operations Manual

Document No. 511011 Rev 07-01-19

Copyright

© Copyright 2014, QUALSTAR. All rights reserved. This document and the information contained herein are the property of QUALSTAR. No part of this document may be reproduced, transmitted, transcribed, stored in a retrieval system, or translated into any language or computer language in any form or by any means, electronic, mechanical, magnetic, optical, manual, or otherwise, without the express written permission of QUALSTAR.

Trademark Notices

QUALSTAR makes no representation or guarantees with respect to the contents of this document and specifically disclaims any implied warranties of merchantability or fitness for any particular purpose. Further, QUALSTAR reserves the right to revise this publication without obligation of QUALSTAR to notify any person or organization of such revision or changes.

Q24™ and Q48™ are Trademarks of Qualstar Corporation

Revision History

Date	Issue	Revision	Author	Description of changes
2014-04-04	Initial release	01	Dennis Klein	
2015-06-12		02	Michael Smith	Add Q48 model
2015-09-30		03	David Mana	Additional Q48 updates
2016-01-12		04	Michael Smith	Corrected mounting instructions
2016-04-28		05	Michael Smith	Updated Address
2018-01-26		07	Kevin Yi	Added LTO8
2019-07-01		07-01-19	Kevin Yi	Updated Address

Contacting Qualstar

Sales

Qualstar Corporation
1267 Flynn Road
Camarillo, CA 93012, U.S.A.
Tel: 805-583-7744
877-886-2758 (Toll Free)

Technical Support

Email: support@Qualstar.com
Tel: 805-416-7055

For non-urgent questions, please use the form on our website at:
<http://www.qualstar.com/service-requests/>

Product warranty caution

The Q24/Q48 Tape Library contains no user-serviceable components. Only an authorized service center should carry out any servicing or repairs. The warranty for the tape library shall not apply to failures of any unit when:

- Any of the tape library components is repaired or modified by anyone other than Qualstar's personnel or approved agent. **Note:** Certain components of the Q24/Q48 Tape Library, are identified in this manual as 'field replaceable'. These include the power supply, tape drives, library controller and magazines. User replacement of such complete components with corresponding parts supplied by Qualstar does not affect warranty, provided the user strictly adheres to the instructions herein.
- The tape library is physically abused, or used in a manner that is inconsistent with the operating instructions or product specification defined by Qualstar.
- The tape library fails because of accident, misuse, abuse, neglect, mishandling, misapplication, alteration, faulty installation, modification, or service by anyone other than the factory service center or its approved agent.
- The tape library is repaired by anyone, including an approved agent, in a manner that is contrary to the maintenance or installation instructions supplied by Qualstar.
- The manufacturer's serial number tag is removed.
- The tape library is damaged because of improper packaging on return.

In case of unauthorized repairs or modifications, your warranty becomes immediately void.

General warnings



DANGER

High voltage - Risk of electric shock

- Do not remove cover (or back). No user-serviceable parts are inside.
 - Refer servicing to qualified service personnel.
-



WARNING

Weight of Q24/Q48 Tape Library - Risk of personal injury

Before lifting a library:

- Observe local health and safety requirements and guidelines for manual material handling.
- Remove all tape cartridges to reduce the weight.
- Obtain adequate assistance to lift and stabilize the library during installation or removal.

Risk of damage to devices

When placing a library into or removing the library from a rack:

- Extend the rack's leveling jacks to the floor.
 - Ensure that the full weight of the rack rests on the leveling jacks.
 - Install stabilizing feet on the rack.
 - Extend only one rack component at a time.
-



CAUTION

Static sensitive - Risk of damage to devices

- A discharge of static electricity damages static-sensitive devices or micro circuitry.
 - Proper packaging and grounding techniques are necessary precautions to prevent damage.
-



NOTE

- **Ventilation** – Place the product so that its location does not interfere with proper ventilation.
 - **Heat** – Place the product so that its location is away from heat sources.
 - **Power sources** – Connect the product to a power source only of the type directed in the operating instructions or as marked on the product.
 - **Power cord protection** – Place the AC line cord so that it is not possible to be walked on or pinched by items placed upon or against it.
 - **Object and liquid entry** – Insure that objects do not fall and liquids are not spilled into the product's enclosure.
-

Contents

1	Product Overview and Features	1
1.1	Hardware Configuration.....	2
1.1.1	Q24 Tape Library	2
1.1.2	Q48 Tape Library	2
1.2	Front Panel	3
1.2.1	Q24 Tape Library Front panel	3
1.2.2	Q48 Tape Library Front panel	3
1.3	Rear Panel.....	5
1.3.1	Q24 Power supply	6
1.3.2	Q48 Power supply	6
1.3.3	Tape drives	6
1.3.4	Library controller.....	7
2	Installation	8
2.1	Location Requirements	8
2.2	Serial Attached SCSI (SAS) Requirements.....	8
2.3	Fibre Channel Requirements	9
2.4	Installation Precautions.....	11
2.5	Unpacking the library	12
2.6	Identifying the product components	12
2.7	Removing the shipping lock.....	13
2.8	Rack mounting the library	14
2.9	Installing a tape drive	15
2.10	Installing the library controller.....	16
2.11	Installing a power supply.....	17
2.12	Connecting the cables	18
2.12.1	Connecting the power cord.....	18
2.12.2	Connecting a Fibre Channel cable.....	18
2.12.3	Connecting a SAS cable	19
2.12.4	Connecting an Ethernet cable and a USB device	19
2.13	Verifying the host	20
2.14	Powering the library up or down.....	20
2.15	Tape cartridges	20
2.15.1	Tape cartridge type	20
2.15.2	Using and maintaining tape cartridges	21
2.15.3	Labeling tape cartridges.....	22
2.15.4	Write-protecting tape cartridges	23
2.16	Magazines.....	23
2.16.1	Slot usage.....	24
3	Operating Procedures.....	25
3.1	Operator control panel (OCP).....	25
3.1.1	Operating Modes	25

3.1.2	OCP Rules	25
3.1.3	Power-Up Display	26
3.1.4	Note about the LED's.....	26
3.1.5	Input Modes.....	26
3.1.6	Power-Down.....	27
3.1.7	Menu flow charts (OCP).....	28
3.2	Remote management unit (RMU).....	35
3.2.1	Overview	35
3.2.2	Operations through the RMU	35
3.2.3	Login.....	36
3.2.4	RMU Screen Layout.....	37
3.2.5	Identity.....	38
3.2.6	Status	42
3.2.7	Configuration.....	45
3.2.8	Operations.....	55
3.2.9	Service	56
3.3	Partitioning the library	61
3.3.1	Q24 Single partition configuration	61
3.3.2	Q24 Dual partition configuration	61
3.3.3	Q48 Single partition configuration	61
3.3.4	Q48 Dual partition configuration	62
3.3.5	Q48 Three partition configuration	62
3.3.6	Q48 Four partition configuration	62
3.4	Default settings	64
4	Troubleshooting.....	65
4.1	Installation problems.....	65
4.1.1	Cabling	65
4.1.2	Compatibility.....	65
4.1.3	Backup application installation	65
4.1.4	Device driver installation.....	65
4.2	Troubleshooting	66
4.3	Removing tape cartridges from the library	69
4.4	Emergency release	70
4.5	Upgrade the library firmware.....	71
4.6	General diagnostic.....	71
4.6.1	System test.....	71
4.6.2	Slot-to-Slot test.....	71
4.6.3	Library verify test.....	71
4.7	Error codes	73
4.7.1	Error messaging.....	73
4.7.2	Error Message format	74
4.7.3	OCP error reporting.....	74
4.7.4	RMU error reporting.....	74
4.7.5	Main error codes.....	75
4.7.6	Sub error codes related to the media changer	85
4.7.7	Sub error codes related to the library.....	87
5	Servicing.....	88

5.1	Tools that may be needed	88
5.2	Electrostatic discharge	88
5.3	Removing a tape drive.....	89
5.4	Replacing a tape drive	89
5.5	Removing the library controller	90
5.6	Replacing the library controller.....	90
5.7	Removing the power supply.....	91
5.8	Replacing the power supply	91
5.9	Servicing a magazine	91
5.10	Removing the base chassis.....	92
5.10.1	Preparing to remove the base chassis	92
5.10.2	Removing the base chassis from the rack.....	92
5.11	Replacing the base chassis	93
6	Packaging the unit for transportation	94
7	Technical specifications	97
7.1	Hardware specifications	97
7.2	Operating environment.....	97
7.3	Maximum storage capacity and data transfer rate.....	98
8	Agency certifications.....	99
8.1	Recycling and disposal.....	99
8.2	Device standards	100
8.3	CE mark.....	100
8.4	ETL mark	100
8.5	GS mark	101
8.6	FCC (United States).....	101
8.7	Canadian verification.....	101
9	Glossary.....	102
10	Index.....	103

Figures

Figure 1	Q24 / Q48 front panel control, indicators and magazines.....	4
Figure 2	Q24/Q48 rear panel components	5
Figure 3	Q24 Power supply	6
Figure 4	Q48 Power supply	6
Figure 5	SAS half-height tape drive.....	7
Figure 6	FC half-height tape drive.....	7
Figure 7	Q24 / Q48 Library controller	7
Figure 8	Fibre Channel topology (LN Port).....	9
Figure 9	Fibre Channel topology (L Port)	10
Figure 10	Fibre Channel topology (N Port)	10
Figure 11	Removing and Storing the Shipping Lock on a Q24	13
Figure 12	Removing and Storing the Shipping Lock on a Q48	13
Figure 13	Install the rack rails	14
Figure 14	Secure the library to the rack.....	15
Figure 15	Pullout tab for product ID	16
Figure 16	Install a tape drive.....	16
Figure 17	Install a library controller	17
Figure 18	Install a power supply	17
Figure 19	Connect the FC cable.....	19
Figure 20	Proper barcode label placement.....	22
Figure 21	Write-protecting a tape cartridge	23
Figure 22	Main menu	28
Figure 23	Information menu (1 of 2).....	29
Figure 24	Information menu (2 of 2).....	30
Figure 25	Commands menu	31
Figure 26	Configuration menu	32
Figure 27	Service menu (1 of 2)	33
Figure 28	Service menu (2 of 2)	34
Figure 29	RMU Login	36
Figure 30	RMU Menu System	37
Figure 31	System Status summary.....	37
Figure 32	Library identity	38
Figure 33	Drive identity.....	40
Figure 34	Network identity	41
Figure 35	Library status.....	42
Figure 36	Drive status	43
Figure 37	Tape cartridge inventory (summary)	44
Figure 38	Tape cartridge inventory (detail)	44
Figure 39	System Configuration	45
Figure 40	Logical Libraries.....	46
Figure 41	License key	47
Figure 42	Drive configuration.....	47
Figure 43	Network configuration	48

Figure 44	SNMP configuration	50
Figure 45	User account settings.....	51
Figure 46	Date/time settings.....	52
Figure 47	Error Log mode.....	53
Figure 48	Event parameters for Email Notification.....	53
Figure 49	Factory defaults.....	54
Figure 50	Move media	55
Figure 51	Media Inventory.....	55
Figure 52	Release magazines	56
Figure 53	Library diagnostics.....	56
Figure 54	Drive diagnostics	57
Figure 55	Firmware updates	57
Figure 56	Reboot the library	58
Figure 57	Library logs	58
Figure 58	Clean a tape drive.....	59
Figure 59	Cartridge Memory.....	60
Figure 60	Removing a stuck tape	69
Figure 61	Rear panel (access holes)	70
Figure 62	Front panel (magazine removal)	70
Figure 63	OCP Error display.....	74
Figure 64	RMU Error display	74
Figure 65	Remove a tape drive	89
Figure 66	Remove the library controller	90
Figure 67	Remove the power supply	91
Figure 68	Re-installing Shipping Lock.....	93
Figure 69	Product ID label.....	94
Figure 70	Packaging the Q24 library	95
Figure 71	Packaging the Q48 library	95
Figure 72	WEEE symbol.....	99
Figure 73	Device standards.....	100

Tables

Table 1	Location requirements	8
Table 2	Tape cartridge type	20
Table 3	Backward compatibility (tape cartridges)	21
Table 4	Legend of status icons (RMU).....	38
Table 5	Default settings.....	64
Table 6	Troubleshooting	68
Table 7	Error codes	84
Table 8	Packaging the library	96
Table 9	Hardware specifications	97
Table 10	Operating environment.....	97
Table 11	Q24 Maximum storage capacity and data transfer rate	98
Table 12	Q48 Maximum storage capacity and data transfer rate	98

1 Product Overview and Features

This manual provides information about installing, operating, troubleshooting and servicing a Qualstar Q24 or Q48 Tape Library. It is intended for system administrators and general users who need physical and functional knowledge of the Q24 or Q48 Tape Library.

The two libraries are similar, physically and functionally. The primary difference is the height of the Q48. The Q48 is twice the height of the Q24. The Q48's added height increases the tape cartridge capacity to 48 slots, and the number of tape drives to a maximum of four.

This document uses the reference Q24/Q48 to refer to either the Q24 or the Q48 Tape Library.

The Q24/Q48 Tape Library provides a compact, high capacity, low-cost solution for simple, unattended data backup. It is compatible with most host operating systems and environments provided the host is equipped with the appropriate interface card. However, the library requires either direct support from the operating system or a compatible backup application to take full advantage of its many features.

Major characteristics of the Q24/Q48 Library include:

- Platform – support for either one or two half-height LTO5, LTO6, LTO7, or LTO8 tape drives in a Q24 Tape Library, and one to four in a Q48 Tape Library.
- Connectivity – Fibre Channel (FC) and/or Serial Attached SCSI (SAS) depending upon installed tape drives
- Expandability – additional half-height tape drives may be field-installed in a library that has unused drive slot locations.
- Technology upgrade – tape drive technologies can be upgraded in the field (i.e. LTO5 to LTO6, LTO7 or LTO8)
- Service friendly design – easy access to magazines, tape drives, library controller and power supply for field replacement
- Maximum up time – through advanced error handling and recovery capability

The Q24/48 Library includes the following features:

- USB interface to enable serviceability features (library and drive firmware upgrades) and/or customized features (storage on demand) implementation
- The library can be operated via the front operator control panel (OCP), over the network or the Internet via the integral remote management unit (RMU), or via the storage interface connection from the host application
- Supports industry standard management protocols such as SNMP (SMI-S future development)
- The Q24 has one mailslot for import/export of cartridges during library operation while the Q48 has three mailslots
- Media changer with barcode reader
- Rack-mounted or standalone operation

1.1 Hardware Configuration

1.1.1 Q24 Tape Library

Height:	2U	Tape drives:	1 or 2 half-height drives
Number of magazines:	2 (12 slots each)	Power supply:	1
Number of mailslots:	1	Library controller:	1
Number of tape slots:	24 (less mailslots)		

1.1.2 Q48 Tape Library

Height:	4U	Tape drives:	1 to 4 half-height drives
Number of magazines:	4 (12 slots each)	Power supply:	1
Number of mailslots:	3	Library controller:	1
Number of tape slots:	48 (less mailslots)		

1.2 Front Panel

The front panel of the Q24 and Q48 Tape Library is used to access the power button, operator control panel (OCP), left and right magazines, LED's, and the mailslot.

1.2.1 Q24 Tape Library Front panel

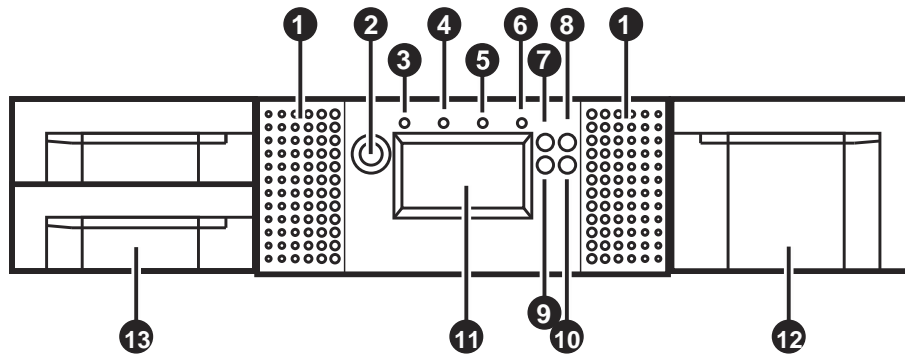

1.2.2 Q48 Tape Library Front panel

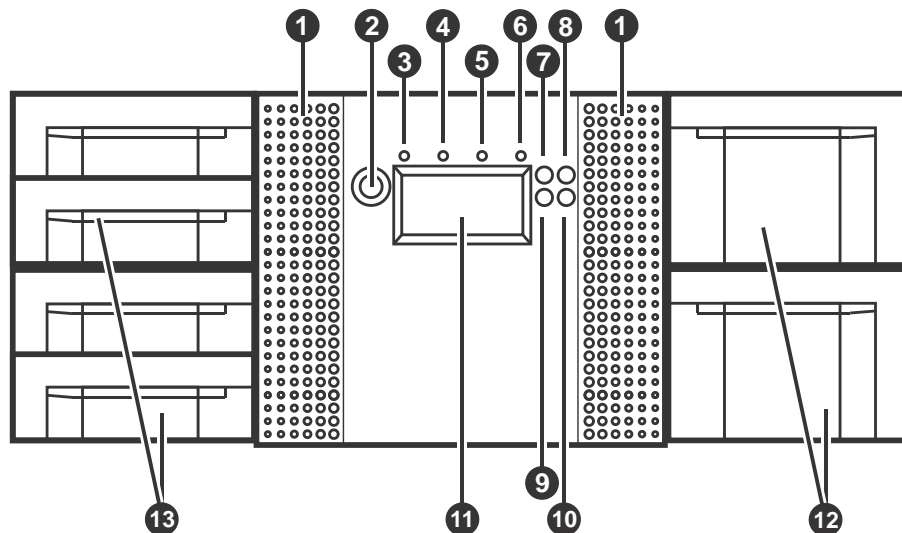

Ref.	Description
1	Air vents
2	Power button: Pressing the button will initiate a controlled power down of the library (soft power down)
3	LED <READY> (green): is illuminated during power on; blinking during tape or library media changer activity.
4	LED <CLEAN> (amber): is illuminated when the tape drive has determined that a cleaning tape should be used. Cleaning is only necessary when the library directs to do so. Additional cleaning is not necessary.
5	LED <ATTENTION> (amber): is illuminated when the library has detected a condition that requires attention by the operator.
6	LED <ERROR> (amber): is illuminated when an unrecoverable tape drive or library error occurs. A corresponding error message is shown on the LCD screen.
7	<UP> button [◀]: is used to navigate backward through menu items.
8	<CANCEL> button [✕]: is used to cancel a user action and return to the last menu item.
9	<DOWN> button [▶]: is used to navigate forward through menu items.
10	<ENTER> button [↵]: is used to enter to a sub menu or execute an action.
11	Operator control panel (OCP) consisting of a 128 x 64 pixel screen. The OCP displays actions and status information, menu items or error messages relevant to the operational mode.
12	Right magazine(s)
13	Left magazine with mailslot(s)

Figure 1 Q24 / Q48 front panel control, indicators and magazines

1.3 Rear Panel

The rear panel of the Q24/Q48 Tape Library provides access to the drive interface connectors (either SAS or Fibre Channel), the power connector, Ethernet, serial and USB ports and the magazine release holes.

The power supply is on the left side, tape drives are in the middle and the library controller is on the right side of the library.

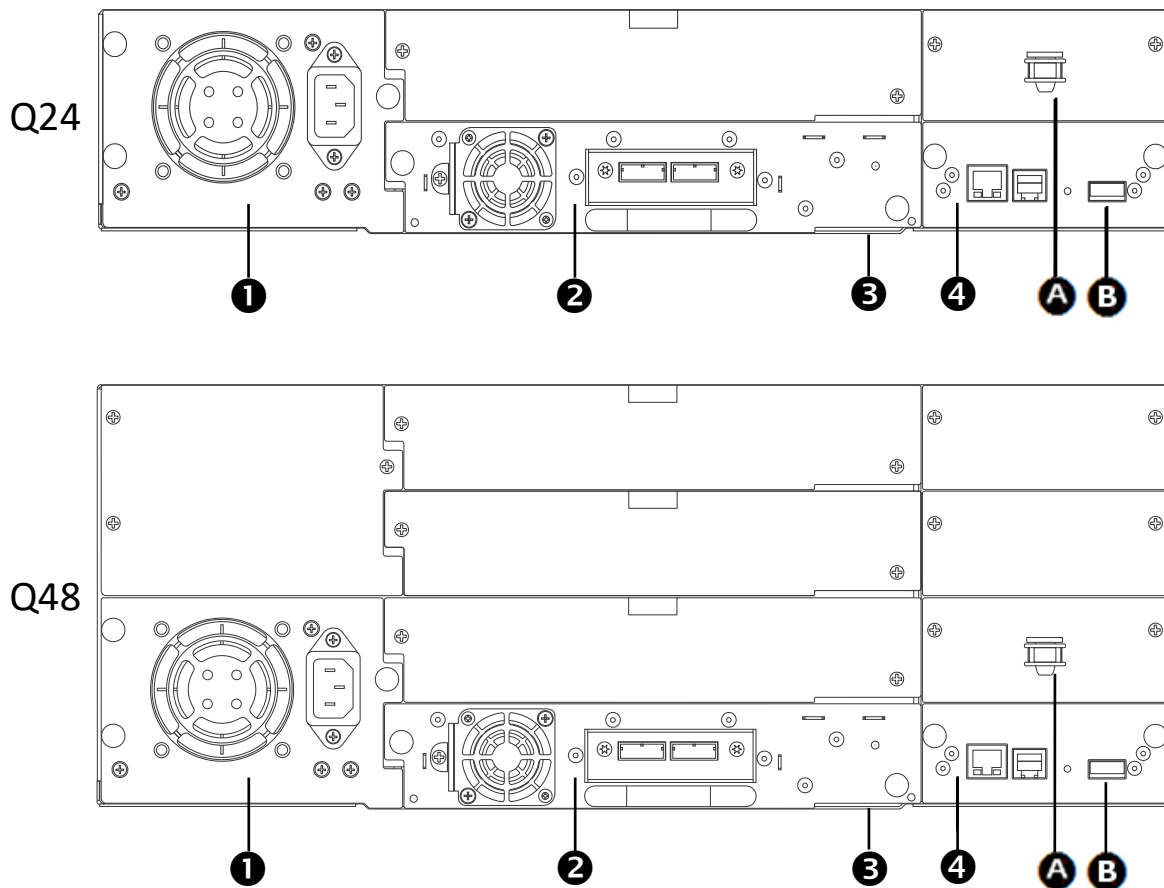

Ref.	Description	Ref.	Description
1	Power supply (lower left)	A	Storage location for shipping lock.
2	Tape drive(s)	B	USB port (firmware upgrades, key storage)
3	Pull-out tab containing the product information (Serial Number/Model/Customer)		
4	Library controller		

Figure 2 Q24/Q48 rear panel components

1.3.1 Q24 Power supply

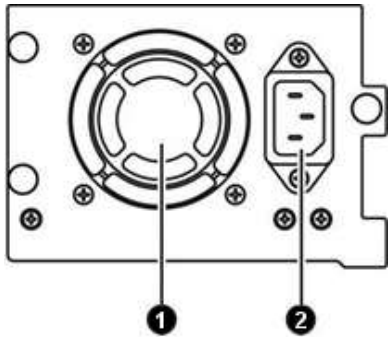

Ref.	Description
1	Fan vent
2	Power connector 110/220 V AC power connection.

Figure 3 Q24 Power supply

1.3.2 Q48 Power supply

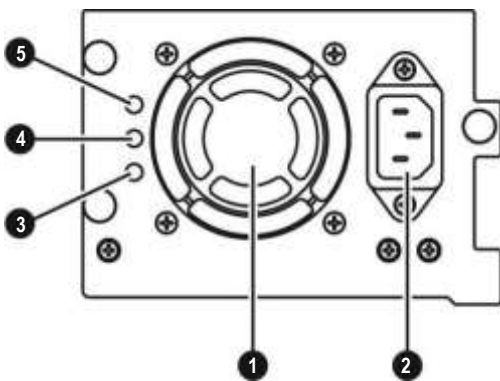

Ref.	Description
1	Fan vent
2	Power connector 110/220 V AC power connection.
3	LED (blue) is illuminated when AC power is connected.
4	LED (amber) is illuminate when a fan failure occurs. The fan is running to slow or defective.
5	LED (green) is illuminated when power is good.

Figure 4 Q48 Power supply

1.3.3 Tape drives

SAS connectors for both LTO Generations

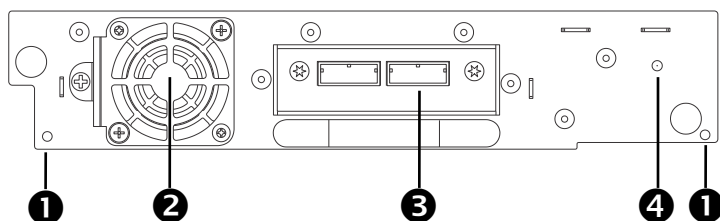

Ref.	Description
1	Magazine release holes
2	Fan vent
3	SAS connectors
4	Tape drive LED

Figure 5 SAS half-height tape drive

FC connectors for both LTO Generations

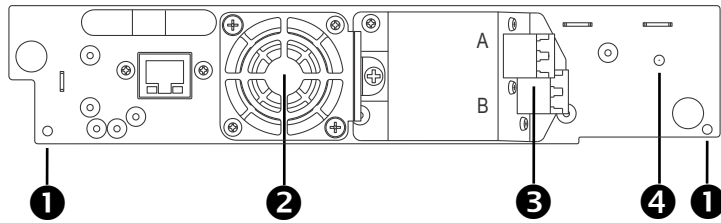

Ref.	Description
1	Magazine release holes
2	Fan vent
3	FC connectors
4	Tape drive LED

Figure 6 FC half-height tape drive

1.3.4 Library controller

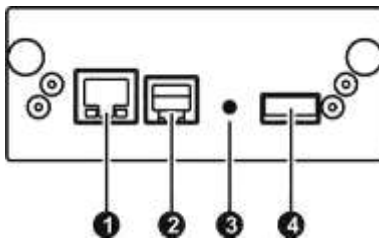

Ref.	Description
1	Ethernet port (RMU connection). Left LED (amber) is illuminated when a connection is in place. Right LED (green) is illuminated when the connection is ready or in use
2	Serial port (Engineering Diagnostics)
3	Controller LED blinking ok; if not, failure
4	USB port (Firmware upgrades, key storage)

Figure 7 Q24 / Q48 Library controller

2 Installation

This section provides instructions for installing the Q24/Q48 Tape Library.

2.1 Location Requirements

Criteria	Definition
Rack requirements	Standard 19-inch rack with vertical space of 2U available for the Q24 or vertical space of 4U available for the Q48.
Room temperature	10-35° C (50-95° F)
Power source	AC power voltage: 100-127 VAC; 200-240 VAC Line frequency: 50-60 Hz Place the library near to an AC outlet. The AC power cord is the library's main AC disconnect device and must be easily accessible at all times.
Air quality	Place the library in an area with minimal sources of particulate contamination. Avoid areas near frequently used doors and walkways, stacks of supplies that collect dust, printers, and smoke-filled rooms. Excessive dust and debris can damage tapes and tape drives.
Humidity	20-80 percent relative humidity non-condensing
Clearance	Back: Minimum of 15.4 cm (6 inches) Front: Minimum of 30.8 cm (12 inches) – for mailslot Minimum of 60 cm to remove magazines (24 inches) Sides: Minimum of 5.08 cm (2 inches)

Table 1 Location requirements

For further information, see **Section 7, Technical specifications**

2.2 Serial Attached SCSI (SAS) Requirements

Serial Attached SCSI (SAS) is a computer bus technology mainly used to transfer data to and from storage devices, including disk drives and tape drives. SAS is designed to transfer data at up to 6 gigabits per second.

SAS uses serial connections, with a direct connection between the host server and each of the storage devices. This eliminates the need to configure SCSI buses and assign SCSI IDs, as was required for parallel SCSI devices.

Most SAS host bus adapters (HBA) ports have four SAS channels. A tape drive uses one channel, so each HBA port can support up to four tape drives via a fan-out cable. You can use a cable with one connector on each end, but only one channel will be used.

**NOTE**

- The library has a mini-SAS connector on each SAS tape drive. Mini-SAS connectors are keyed.

A SAS tape drive is identified by a unique identifier called a World Wide Name (WWN) or World Wide Identifier (WWID). The library assigns the WWID to the drive bay. When a tape drive is replaced, the WWID is re-assigned to the new tape drive.

The operating system tracks the WWID for the tape drive on each HBA channel. Each of the drive connectors on the fan-out cable is associated with an HBA channel. Once a tape drive has been plugged in, it should remain on the same channel to retain the association between the HBA channel and WWID.

2.3 Fibre Channel Requirements

Fibre Channel (FC) allows an active intelligent interconnection scheme, called a Fabric, to connect devices. Everything between the ports on FC is called the Fabric. The Fabric is most often a switch or series of switches that takes the responsibility for routing.

The library allows the selection of the following Fibre Channel port behaviors:

- LN Port (default setting) – an automatic configuration that tries arbitrated loop first, then switched Fabric.

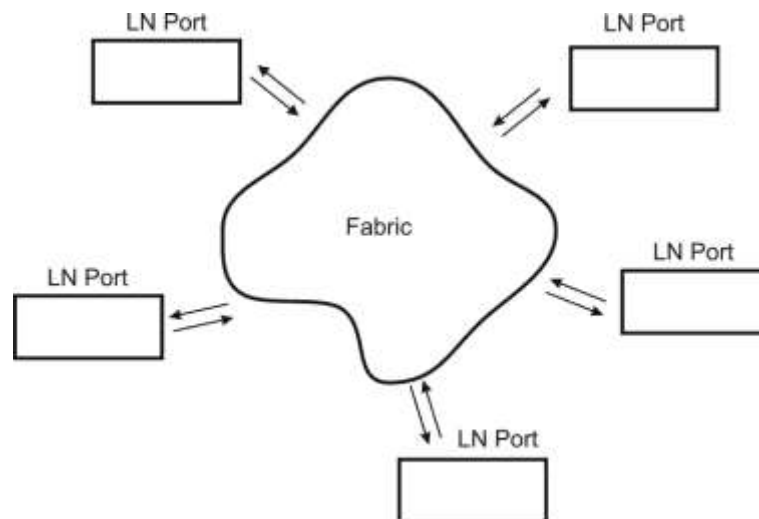

Figure 8 Fibre Channel topology (LN Port)

- L Port – arbitrated loop

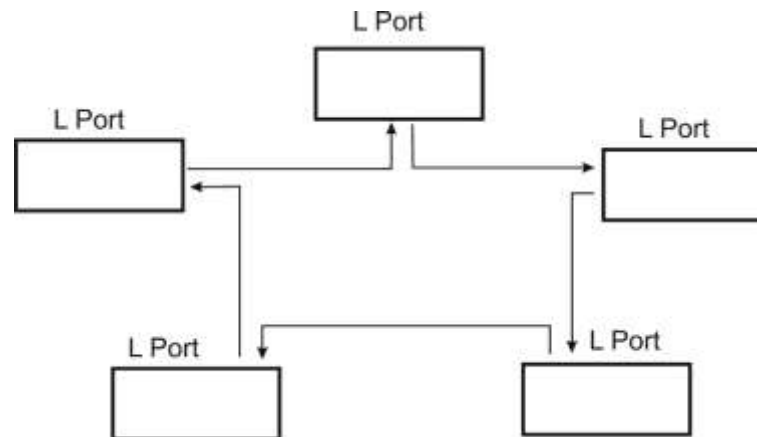

Figure 9 Fibre Channel topology (L Port)

- N Port – point to point protocol in a switched Fabric topology



Figure 10 Fibre Channel topology (N Port)

The Fibre Channel tape drive can be connected directly to the server with a host bus adapter (HBA) or through a storage area network (SAN).



NOTE

- Use an appropriate HBA for your tape drive due to performance considerations. A lower throughput HBA might result in performance degradation when backing up highly compressible data to a higher throughput tape drive.
- In a SAN installation, all switches between the host and the library must be of the appropriate type. A lower throughput switch in the path may result in performance degradation. Configure zoning so only the backup servers may access the library.

2.4 Installation Precautions



CAUTION

Static sensitive - Risk of damage to devices

- A discharge of static electricity damages static-sensitive devices or micro circuitry.
 - Proper packaging and grounding techniques are necessary precautions to prevent damage.
 - See **Section 5.2, Electrostatic discharge**
-



WARNING

Weight of Q24/Q48 Tape Library - Risk of personal injury

Before lifting a library:

- Observe local health and safety requirements and guidelines for manual material handling.
- Remove all tape cartridges to reduce the weight.
- Obtain adequate assistance to lift and stabilize the library during installation or removal.

Risk of damage to devices

When placing a library into or removing the library from a rack:

- Extend the rack's leveling jacks to the floor.
 - Ensure that the full weight of the rack rests on the leveling jacks.
 - Install stabilizing feet on the rack.
 - Extend only one rack component at a time.
-



NOTE

- Do not expose the library to moisture.
 - Use the library on a firm level surface free from vibration.
 - Do not place anything on top of the library.
-

2.5 Unpacking the library

Before unpacking the library, clear a work surface on which to place the unpacked components. If the library will be installed in a rack, select an open rack location allowing easy access to the host server and an easily accessible power outlet.



NOTE

- If the temperature in the room where the library will be installed varies by 15° C (30° F) or more from the room where the library was stored, allow the library to acclimate to the surrounding environment for at least 12 hours before unpacking it from the shipping container.

1. Before opening and removing the tape library from the box, inspect the container for shipping damage. If you notice any damage, report it to the shipping company immediately.
2. Open the box.
3. Carefully remove the shipping materials from the top of the library.
4. Remove the accessory package and set aside (if included).
5. Remove the two rack rails and set aside (if included).
6. Lift the library out of the carton and remove the bag from the loader. Save the packaging materials for future use.



NOTE

- Do not place the library on either end or sides as this may damage it.

2.6 Identifying the product components

Confirm that you received the following:

1. Q24/Q48 Tape Library, including power supply, 1 or more half-height tape drives (as ordered), library controller, and two tape magazines for the Q24, or four magazines for the Q48.
2. Rack mount kit:
 - 2 rack mount rails
 - 1 bag of eight M6 screws for the rack mounting (9.5 mm square holes in the rack column)
 - 1 bag of eight M6 screws for rack mounting (6.85 mm round holes in the rack column)
3. Power cord
4. Library documentation

Optional components, depending on the purchased configuration:

1. Cables - for instance Fibre Channel and SAS cables

2.7 Removing the shipping lock



NOTE

- The shipping lock, which prevents the media changer transport mechanism from moving during shipment, must be removed before the library is powered on.

To remove and store the shipping lock:

1. Remove the yellow label that is securing the shipping lock on the top of the library.
2. Remove the shipping lock.
3. Store the shipping lock in the slot provided on the rear panel (**Important:** The lock is required if the library is to be returned or transported to a new location at some future time).
4. Replace the yellow label on the top of the library.

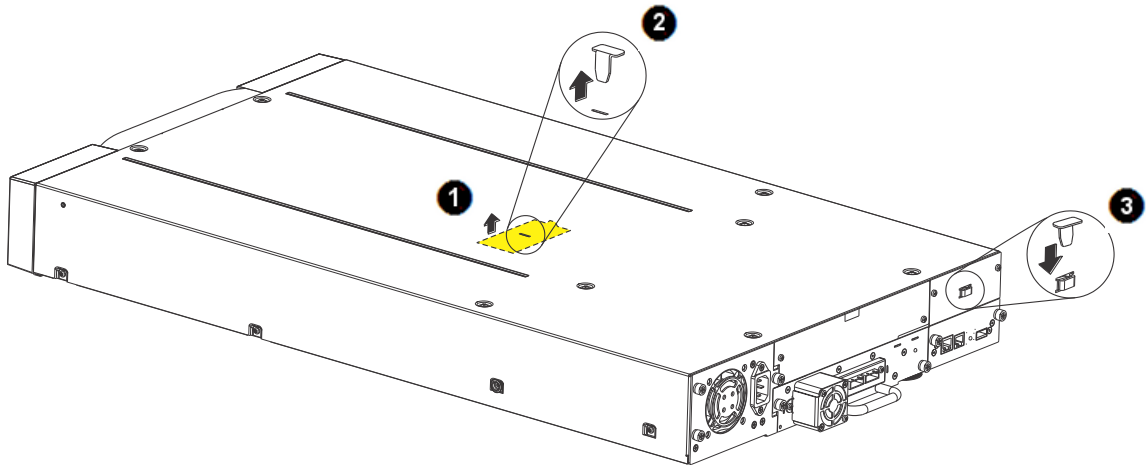

Figure 11 Removing and Storing the Shipping Lock on a Q24

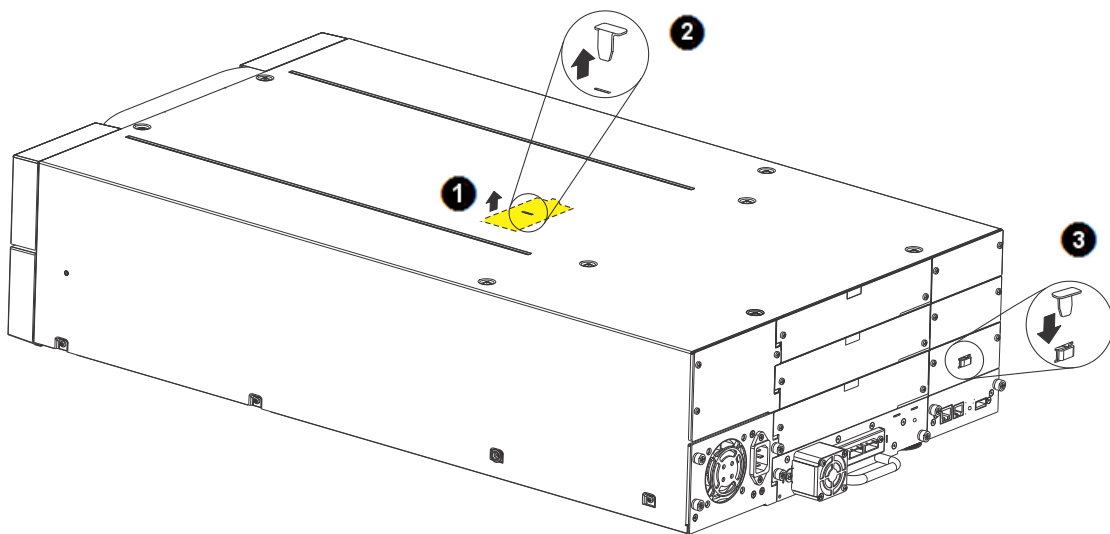

Figure 12 Removing and Storing the Shipping Lock on a Q48

2.8 Rack mounting the library



NOTE

- The rack rail components are optional accessories depending on the ordered configuration. Skip this section, when the rack rail components are not included.

Required tools:

- #3 Phillips screwdriver
- T10 Torx screwdriver

Rack mounting the library:

1. Determine the location in which the library rack is to be installed.
2. Use a pencil to mark the location on each vertical rail in the rack.
3. In the rack mount kit are two sets of eight M6 screws. Determine the type of rack then choose the appropriate type of M6 screws.
4. Secure one rail to each side of the rack in your chosen rack location with a #3 Phillips screwdriver. Insure the rails are mounted level and at the same rack height on each side.
5. Secure both the front and back of each rack rail to the rack.

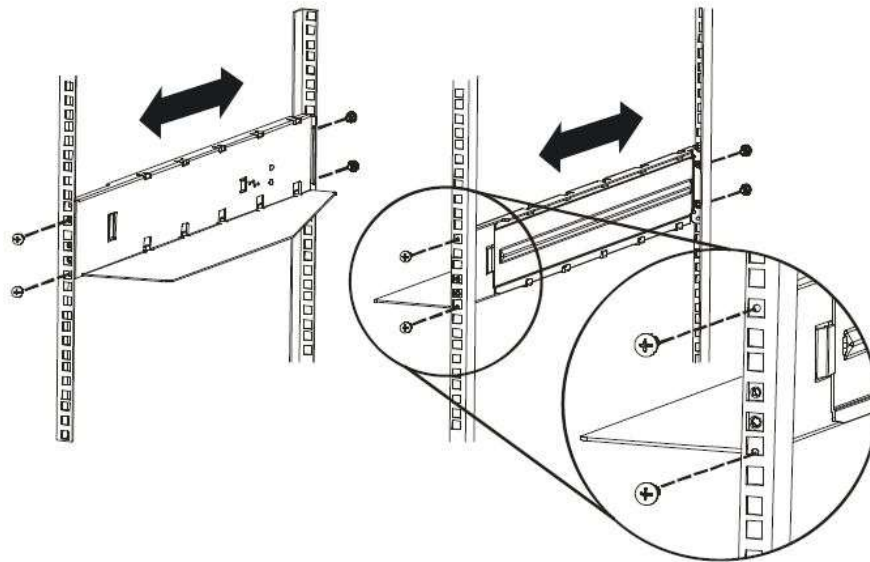

Figure 13 Install the rack rails

6. Slide the library onto the rack rails.

7. Secure the library to the rack using a 3# Phillips screwdriver placed through the small holes in the mounting bracket to tighten the M5 screw(s) on each side of the library.

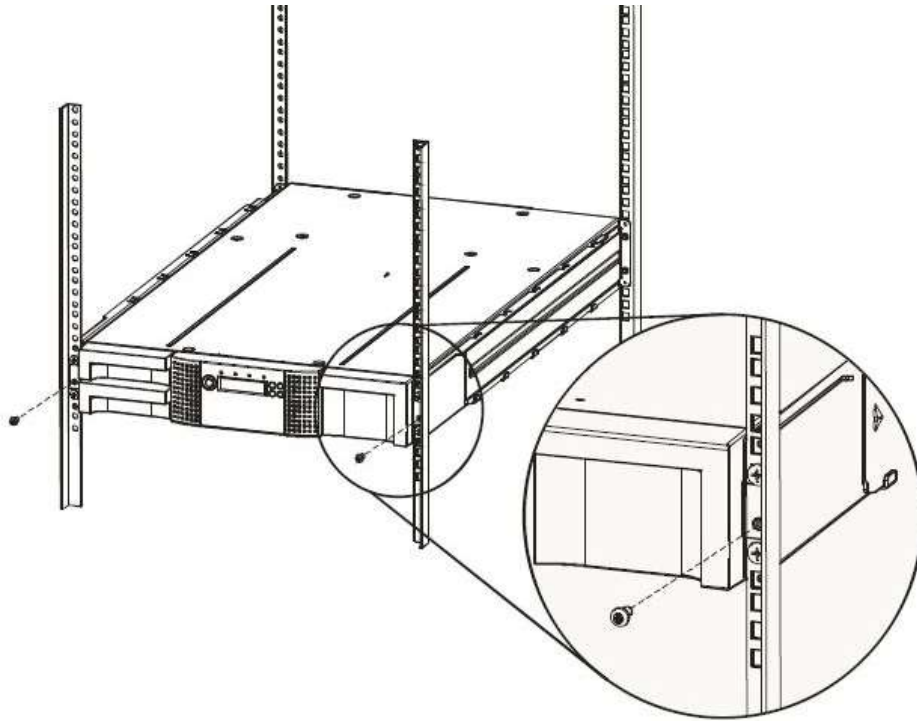

Figure 14 Secure the library to the rack

2.9 Installing a tape drive

A tape drive is installed from the rear of the library. If the library does not already have a tape drive installed, install it now. If the library already has one tape drive installed, an additional tape drive may be added now or after installation of the library is complete.

Required tool:

- #2 Phillips screwdriver

To install tape drives:

1. The Q24 has space for either 1 or 2 half-height tape drives. The Q48 has space for 1 to 4 half-height tape drives. Always install the first tape drive in the bottom of the drive bay. A drive bay cover must be installed over any upper empty drive positions.
2. If a drive cover is present, loosen the screws and remove the cover to install one half-height tape drive.
3. When installing the bottom drive, slightly pull out the tab of the product ID label so it does not interfere with the insertion or removal of the tape drive.

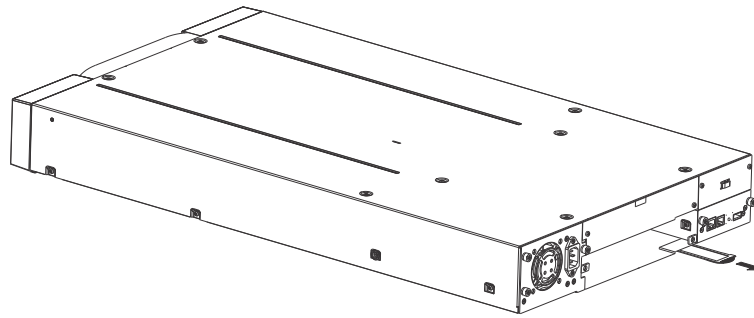

Figure 15 Pullout tab for product ID

4. Before installing the drive, inspect the connectors on it. Ensure that the connectors are intact, free of any foreign objects, and have no cracks, or deformed or bent contacts.
5. Insert the tape drive into the drive bay, and align the connectors on the library while supporting the drive.

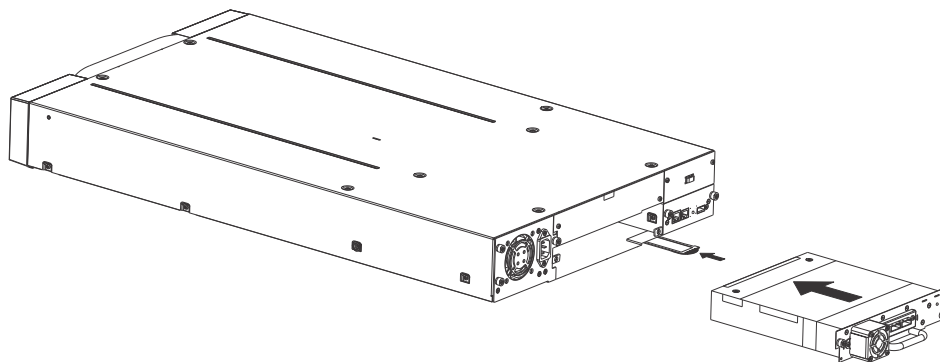

Figure 16 Install a tape drive

6. Push the tape drive into the drive bay until the tape drive seats itself against the back of the library. If extended, push the tab for the product ID label back into the library.
7. Tighten the blue captive screws with your fingers to secure the tape drive to the library.

2.10 Installing the library controller

The library controller is installed from the rear of the library. If the library does not already have a library controller installed, install it now.

Required tool:

- #2 Phillips screwdriver

To install a library controller:

1. Locate the vacant library controller bay on the lower right side of the rear panel.
2. If present, loosen the screws and remove the library controller bay cover.
3. Before installing the library controller, inspect its connectors. Ensure that the connectors are intact, free of any foreign objects, and have no cracks or deformed or bent contacts.

4. Insert the library controller on the alignment rails and push it into the bay until it seats itself against the back of the library.

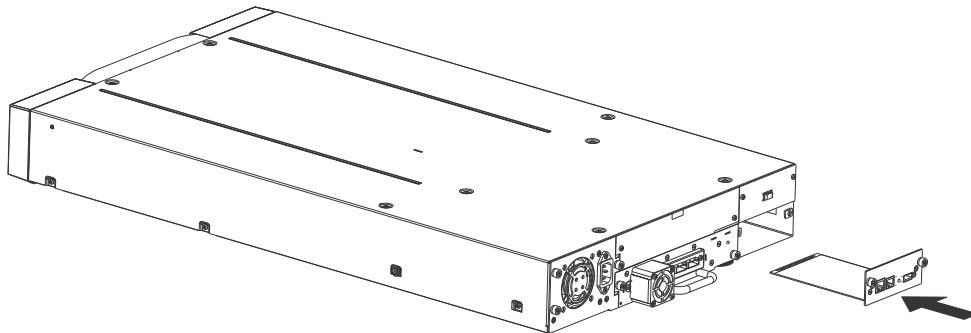

Figure 17 Install a library controller

5. Tighten the blue captive screws with your fingers to secure the library controller.

2.11 Installing a power supply

The power supply is installed from the rear of the library. If the library does not have a power supply installed, install it in the left power supply bay now.

Required tool:

- #2 Phillips screwdriver

To install a power supply:

1. Locate the power supply bay on the lower left side of the rear panel of the library.
2. If present, loosen the screws and remove the power supply bay cover.
3. Before installing the power supply, inspect its connectors. Ensure that the connectors are intact, free of any foreign objects, and have no cracks or deformed or bent contacts.

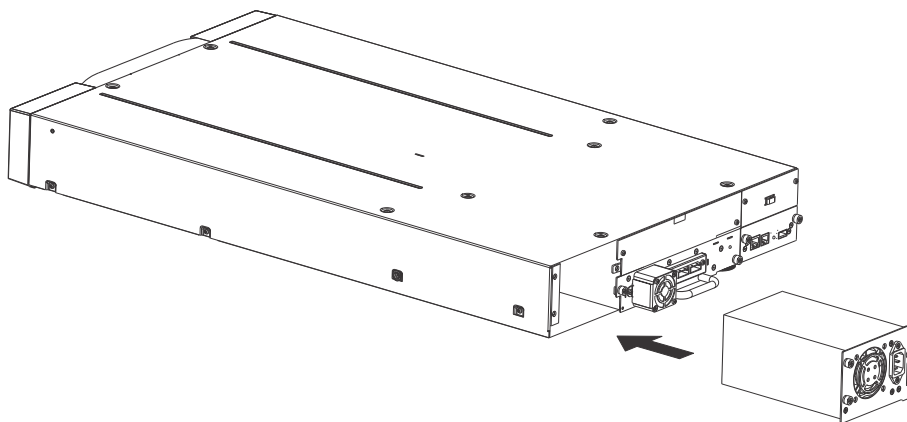

Figure 18 Install a power supply

4. Insert the power supply on the alignment rails and push it into the bay until it seats itself against the back of the library.

5. Tighten the blue captive screws with your fingers to secure the power supply to the library.

2.12 Connecting the cables

2.12.1 Connecting the power cord



DANGER

High voltage - Risk of electric shock

- Use only approved power cords.
 - Observe local health and safety requirements and guidelines for manual material handling.
-



WARNING

Usage of non-approved power cords

- **Risk of personal injury**
- **Risk of damage to devices**

Before connecting a power cord to the library:

- Ensure that the power cord meets individual country specific safety standards.
- Use a sufficient conductor current capacity (amps) to avoid overheating the cord.

The manufacturer disclaims all liability in the event a non-manufacturer approved power cord is used.

To connect the power cord to the library:

1. Plug the female connector of the power cord into the power connector (AC connector) on the rear panel of the power supply. For the Q24, refer to section **1.3.1 Q24 Power supply**. For the Q48, refer to section **1.3.2 Q48 Power supply**.
2. Plug the male connector into an appropriate electrical socket.

2.12.2 Connecting a Fibre Channel cable



NOTE

Use only cables specified for your LTO Fibre Channel tape drive. Each FC tape drive has two FC ports.

- Cable **[Port A]** only.
 - Configure **[Port B]** for <Auto Detect> on <Fibre Speed> and <Port Type>.
-

To connect the FC cable to the tape drive:

1. Remove the FC port caps if necessary. Attach one end of the FC cable to [Port A] on the tape drive.

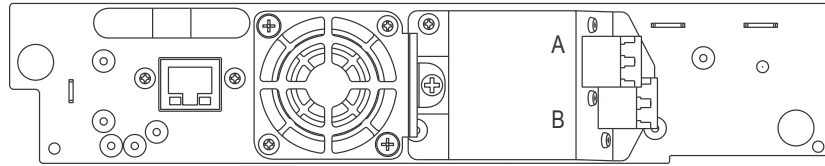

Figure 19 Connect the FC cable

2. Attach the other end of the FC cable to a switch or host bus adapter (HBA).

2.12.3 Connecting a SAS cable



NOTE

Use only cables specified for your LTO SAS tape drive. Each SAS tape drive has a mini-SAS connector.

- Mini-SAS connectors are keyed.
- Do not force a SAS cable's mini-SAS connector into the tape drive mini-SAS connector because it might be keyed differently.

SAS signal rates require clean connections and a minimum number of connections between the HBA and the library.

- Do not use adapters or converters between the HBA and the library.
- A maximum SAS cable length of six meters is recommended.

To connect the SAS cable to the tape drive:

1. Plug the HBA end of the SAS cable into the connector on the HBA.
 - If you have a SAS fan-out cable, the end of the cable with only one connector, should be plugged into the connector on the HBA.
 - If you are using a cable with a single connector on each end, plug the other end into the connector on the tape drive.
 - If you are using a SAS fan-out cable, plug one mini-SAS connector into the connector on each tape drive. The unused ends of the SAS fan-out cable are single channel and not suitable for use with disk arrays. Use the other ends to connect tape drives, or coil and secure them to the rack to minimize stress on the connectors.

2.12.4 Connecting an Ethernet cable and a USB device

To connect the Ethernet cable to the library:

The connection to the Ethernet network is via an industry standard RJ45 copper interface on the rear panel of the library. The Ethernet connection is used to access the library RMU over a network.

To connect the library to the Ethernet network, insert the Ethernet cable into the Ethernet port of the library. When the plug is in the correct position, a click should be heard.

To connect the USB device to the library:

The USB port is on the rear of the library. It can be used for firmware upgrades/skin file updates initiated via the operator control panel (OCP).

2.13 Verifying the host

When the host server is powered on, install the software and/or driver(s) that are compatible with the library. Backup software packages may require additional software or licensing to communicate with the library media changer.

To confirm that the host server's operating system has recognized the library, consult the operating system documentation.

2.14 Powering the library up or down

Press the power button on the front panel of the Q24 Tape Library to power it up or down. Powering up can take a few minutes because it includes scanning the inventory and configuration (e.g. how many and what type of drives are installed)

2.15 Tape cartridges

Before you begin using the library, an understanding of the media type, use, maintenance, and how to properly label and write-protect your tape cartridges, will help you to prolong the life of your tapes as well as the library.

2.15.1 Tape cartridge type

The tape cartridge types supported depend on the drive types installed. The library will support any type of LTO data cartridge and cleaning cartridge that the installed LTO drive will support.

Tape drive generation	Tape cartridge type
LTO5	<ul style="list-style-type: none"> ▪ Ultrium LTO5, 1.5 TB data cartridge ▪ Universal cleaning cartridge, (50 cleans)
LTO6	<ul style="list-style-type: none"> ▪ Ultrium LTO6, 2.5 TB data cartridge ▪ Universal cleaning cartridge, (50 cleans)
LTO7	<ul style="list-style-type: none"> ▪ Ultrium LTO7, 6 TB data cartridge ▪ Universal cleaning cartridge, (50 cleans)
LTO8	<ul style="list-style-type: none"> ▪ Ultrium LTO8, 12 TB data cartridge ▪ Universal cleaning cartridge, (50 cleans)

Table 2 Tape cartridge type

	LTO5 tape drive	LTO6 tape drive	LTO7 tape drive	LTO8 tape drive
LTO1 media	Incompatible	Incompatible	Incompatible	Incompatible
LTO2 media	Incompatible	Incompatible	Incompatible	Incompatible
LTO3 media	Read only	Incompatible	Incompatible	Incompatible
LTO4 media	Read / Write	Read only	Incompatible	Incompatible
LTO5 media	Read / Write	Read / Write	Read only	Incompatible
LTO6 media	Incompatible	Read / Write	Read / Write	Incompatible
LTO7 media	Incompatible	Incompatible	Read / Write	Read / Write
LTO8 media	Incompatible	Incompatible	Incompatible	Read / Write

Table 3 Backward compatibility (tape cartridges)

Some tape drives include support for both rewriteable and WORM data cartridges. Write-Once, Read-Many (WORM) data cartridges provide an enhanced level of data security against accidental or malicious alteration of data on the tape cartridge. The WORM data cartridge can have new data appended to the maximum full capacity of the tape cartridge, but the user will be unable to erase or overwrite any data previously recorded to the cartridge.

2.15.2 Using and maintaining tape cartridges



NOTE

- Do not degauss Ultrium LTO data cartridges! These data cartridges are pre-recorded with a magnetic servo signal. This signal is required in order to use the cartridge with Ultrium LTO tape drives.
- Keep Ultrium LTO cartridges separated from strong magnetic fields such as computer monitors, electric motors, speakers, or X-ray equipment.
- Exposure to electromagnetic energy or magnetic fields can destroy data and the embedded servo code written on the media by the cartridge manufacturer, which can render the cartridge unusable.

To ensure the longest possible life for your data cartridges follow these guidelines before using the library:

- Use only the data cartridges that are designated for your model of the library
- Clean the tape drive when the <Clean Drive> LED is illuminated. Be sure to use only Ultrium universal cleaning cartridges.
- Do not drop an LTO data cartridge. Excessive shock can damage the internal contents of the tape cartridge, or the tape cartridge case itself, making that tape cartridge unusable.
- Do not expose your data cartridges to direct sunlight or sources of heat, including portable heaters and heating ducts.

- The operating temperature range for your data cartridges is 10 to 35° C. The storage temperature range is -40 to +60° C in a dust-free environment in which relative humidity is always between 20 percent and 80 percent (non-condensing).
- If the data cartridge has been exposed to temperatures outside the ranges specified above, stabilize the cartridge at room temperature for the same amount of time it was exposed to extreme temperatures or 24 hours, whichever is less.
- Place identification labels only in the designated area on the tape cartridge. Labels placed in other areas can cause operational problems and the tape to become stuck in the drive.

2.15.3 Labeling tape cartridges

Attaching a barcode label to each tape cartridge enables the library and application software to identify the tape cartridge quickly, thereby speeding up inventory search time. Make it a practice to use bar code labels on your tape cartridges.

Your host software may need to keep track of the following information via the associated barcode:

- Date of format or initialization
- Tape's media pool
- Data residing on the tape
- Age of the backup
- Errors encountered while using the tape cartridge (to determine if the tape cartridge is faulty).



NOTE

- The misuse and misunderstanding of bar code technology can result in backup and restore failures. To ensure that your bar codes meet Qualstar's quality standards, always purchase them from an approved supplier and never print bar code labels yourself.

Ultrium tape cartridges have a recessed area located on the front of the cartridge next to the write-protect switch. Use this area for attaching the adhesive-backed bar code label. Only apply labels as shown in **Figure 20**.

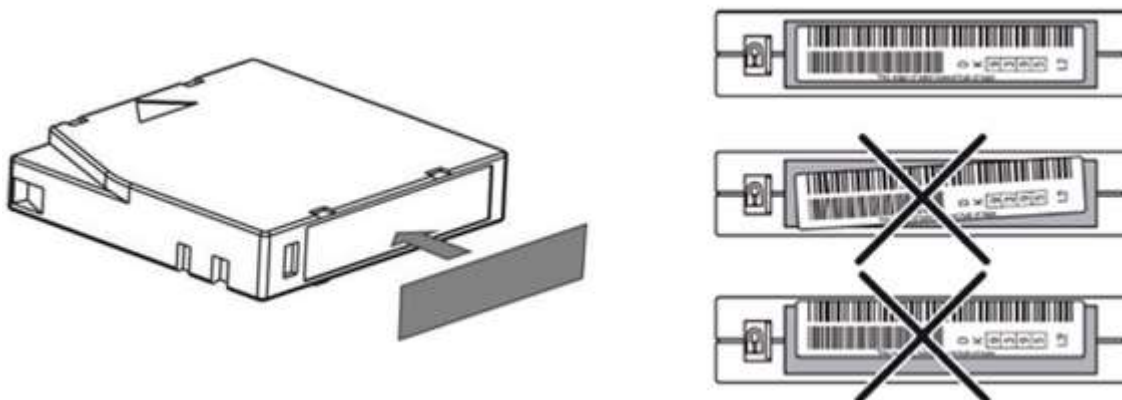

Figure 20 Proper barcode label placement

**NOTE**

- The bar code label should only be applied with the alpha-numeric portion facing to the left- side of the tape (toward the write protect switch) and within the marked Barcode label area.
- Never apply multiple labels onto a cartridge, as extra labels can cause the cartridge to jam in a tape drive.
- Cleaning tapes require a bar code label beginning with CLN

2.15.4 Write-protecting tape cartridges

All rewritable data cartridges have a write-protect switch to prevent accidental erasure or overwriting of data. Before loading a cartridge into the library, make sure the write-protect switch on the front of the cartridge is in the desired position.

- Slide the switch to the right to write-protect the cartridge. A small padlock symbol is visible indicating that the cartridge is write-protected.
- Slide the switch to the left to allow the Library to write data to the cartridge.

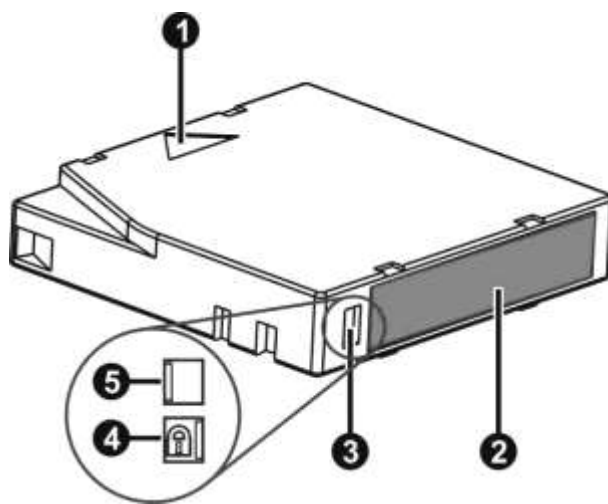

Ref.	Description
1	Insertion arrow
2	Barcode label
3	Write-protect switch
4	Write-protected
5	Write-enabled

Figure 21 Write-protecting a tape cartridge

2.16 Magazines

The Q24/Q48 Tape Library makes use of removable magazines. Tape cartridges are stored in the magazines. Each magazine can be individually removed, or inserted. Each magazine inserted in the library, is locked into position, to prevent unauthorized removal. Access to unlock the magazines can be password protected. For safety reasons, removal of a tape magazine disables media changer motion.

The magazines can be unlocked via the Operator Control Panel (OCP) or the Remote Management Unit (RMU).

- OCP, see **Figure 25**

- RMU, see **Section 3.2.8.3, Releasing and replacing Magazines**

In case the OCP or RMU initiated process fails or the library no longer has power, a manual emergency release is available, see **Section 4.4, Emergency release**.

2.16.1 Slot usage

Each magazine contains 12 slots for tape cartridge storage. However, the lower front slot in the left hand magazine functions as a “mailslot”.

The mailslot is used to import/export individual tape cartridges without interrupting the library operation. The command to open the mailslot may be denied if the media changer is busy with some operation. In that case, “Busy” is displayed on the OCP and the command has to be repeated once the media changer operation is finished.

3 Operating Procedures

This section provides information about operating and configuring the Q24/Q48 Tape Library.

3.1 Operator control panel (OCP)

3.1.1 Operating Modes

The OCP operates in two basic modes:

1. User interaction mode: This mode is employed when a user is pushing buttons on the operating panel.
2. System driven mode: This is the normal mode of operation. In this mode, the operating panel displays status associated with the actions that were caused from commands issued from the host software application. Actions like loading, rewinding or moving tape cartridges will be displayed.

Whenever an operating button is pressed and released, the operating panel automatically transitions to user interaction mode. The user interaction mode will be active until 3 minutes after the user stops pushing buttons, or the requested media changer activity stops – whichever is longer. At this time, the operating panel will return to the system driven mode.

In the event that the administrator-programmed user security feature is in use, the user interaction mode is restricted to the information and login menu screens, until a login with correct PIN is entered.

3.1.2 OCP Rules

OCP commands obey the following basic rules:

1. Any operational conflict between commands received from the host interface or RMU and those entered via the front panel will be avoided with a reservation mechanism on a 'first-come, first-served' basis.
Any reservation by OCP is cancelled by an OCP logout or timeout, which cancels the User Interaction Mode.
2. The library firmware will not allow a user to select an impossible request. Those situations include, but are not limited to:
 - Moving a tape cartridge from any source to a full magazine slot
 - Moving a tape cartridge from an empty magazine slot
 - Loading a tape cartridge from any source to a full tape drive
 - Unloading a tape cartridge from an empty tape drive
3. Any error detected by the library or drive controller and not recoverable through predetermined firmware algorithms will be considered as fatal. An error code will be displayed on the LCD and the error LED will become illuminated. The error code will remain on the OCP until a button is pressed, which will cause the OCP to return to the home screen.
4. Numeric error codes are only used for unrecoverable, fatal errors (see **Section 4.7.5, Main error codes**), otherwise text status messages are provided.

3.1.3 Power-Up Display

When the library powers up or resets, it goes through several internally controlled processes that initialize and prepare the unit for normal operation. These processes are called Power-On-Self-Test (POST). While the POST is in process, the OCP will display appropriate information to keep the user informed. When the library finishes POST, it will display the current library status for a defined time or until a front panel key is pressed.

After this initial status screen, the home screen will be displayed until any key is pressed. The home screen shows the overall health of the library, indicating the status of the media changer and the connected drives.

3.1.4 Note about the LED's

All LED's are updated during power up and reset sequences. Upon power up or software reset, the library will illuminate all LED's at some point during the POST process. This will help the user to verify whether all LED's are functional. When initialization starts, all LED's will be extinguished and the ready/activity LED will flash at approximately two-second intervals. When the mechanical initialization is complete, the ready/activity LED will stop flashing and remain constantly illuminated.

If a library failure occurs, the ready/activity LED will be turned off and the error LED will be illuminated. The OCP will also display a specific error code to help identify the failure.

The following are additional operational details regarding the LED's.

- The <Ready/Activity> LED will be lit any time the unit is powered on and functional (i.e. successfully completed the power-on self-test). The LED will blink whenever there is any tape library or drive activity. The LED will also blink when the unit is offline.
- The <Clean> LED will only be lit when a 'cleaning required' has been issued by one of the drives. The LED will be turned off after a successful drive cleaning operation is performed to the requesting drive.
- The <Media Attention> LED will indicate that there is a piece of LTO media which is bad, marginal or invalid. The LED will be cleared when all such cartridges have been exported from the tape library.
- The <Error> LED will be lit when there is an unrecoverable (i.e. hard) drive or tape library failure. This will occur simultaneously with the hard error message displayed on the screen; the LED will remain illuminated until the error state is resolved.

3.1.5 Input Modes

There are several modes for entering values in the different menu items. These values may be selectable predefined values, toggle values (e.g. on/off) or numerical values like network addresses.

Selectable predefined values

After navigating to the menu item, the various predefined values can be selected with the <DOWN> and <UP> buttons. As soon as the display shows the desired value, it may be confirmed by pressing the <ENTER> button.

Toggle values

Toggle values are used to switch between two different states like 'on' and 'off'. After navigating to the menu item the display shows its current state. Pressing the <ENTER> button will select the item, whose value may then be toggled using the <UP> and <DOWN> buttons. Pressing <ENTER> again sets the item to the displayed value.

Numerical values

Numerical values are needed for network addresses, PIN entries, and other configuration entries. After navigating to the menu item to be changed, the actual value will be displayed and the cursor stays on the first digit. The value may be incremented / decremented with the <DOWN> and <UP> buttons. After pressing the <ENTER> button to select the displayed value, the cursor moves to the next editable digit. Each digit can be changed in the same way. After pressing the <ENTER> button at the last digit, the complete entry will be stored. Pressing the <CANCEL> button will cancel the whole edit process and the old value will be restored.

3.1.6 Power-Down

Pressing the Power button on the library while it is operational will initiate a controlled power down.

The following operations will take place before the unit shuts down completely:

- The display indicates with an appropriate message that the shutdown is in progress.
- The library controller finishes all ongoing loader and drive activities.
- The media changer is moved to its home position.
- The library controller switches off the power supply's secondary side.

**NOTE**

- The shutdown process may be aborted by pressing the cancel button within the first 3 seconds.
-

3.1.7 Menu flow charts (OCP)

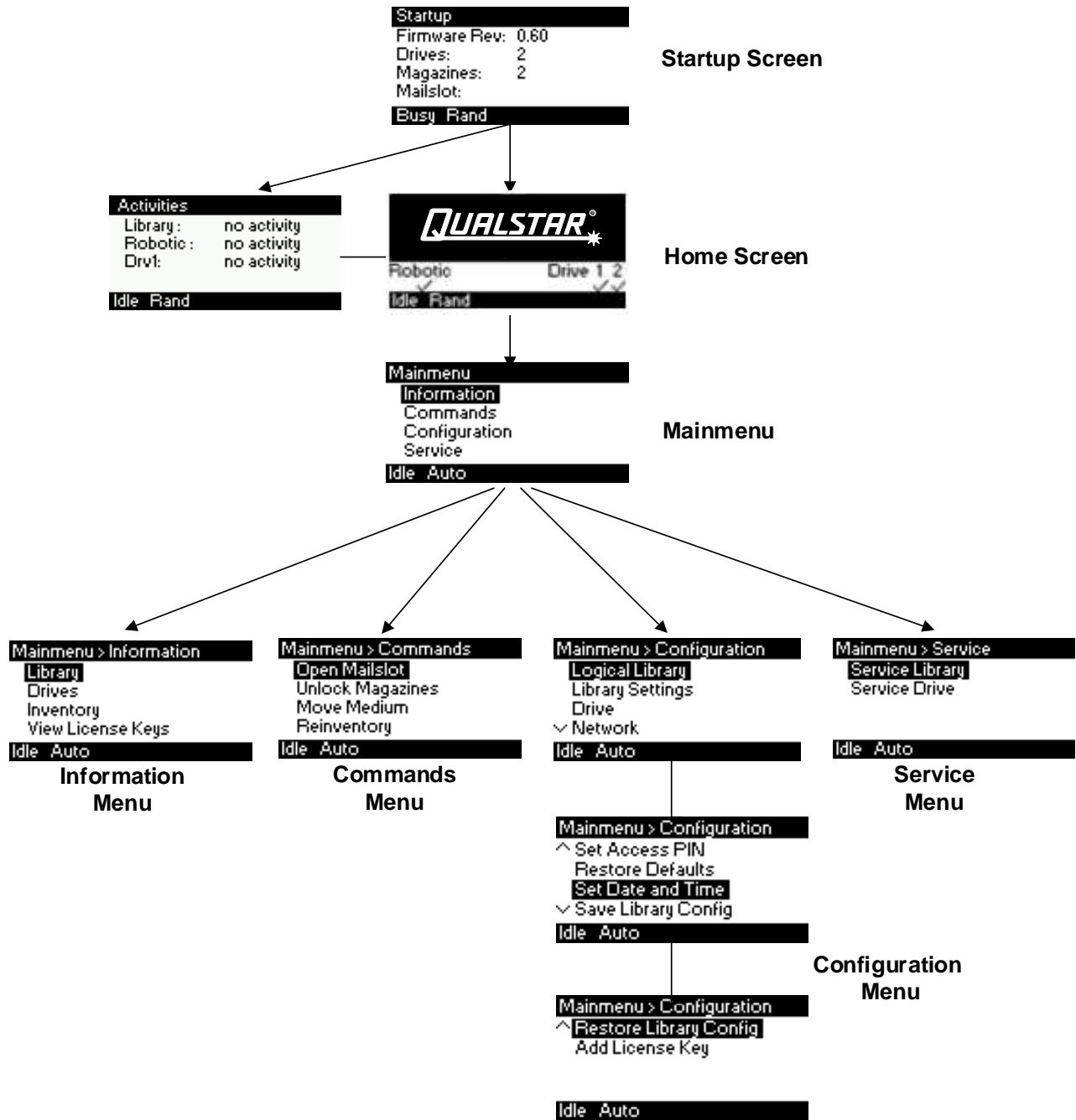

Figure 22 Main menu

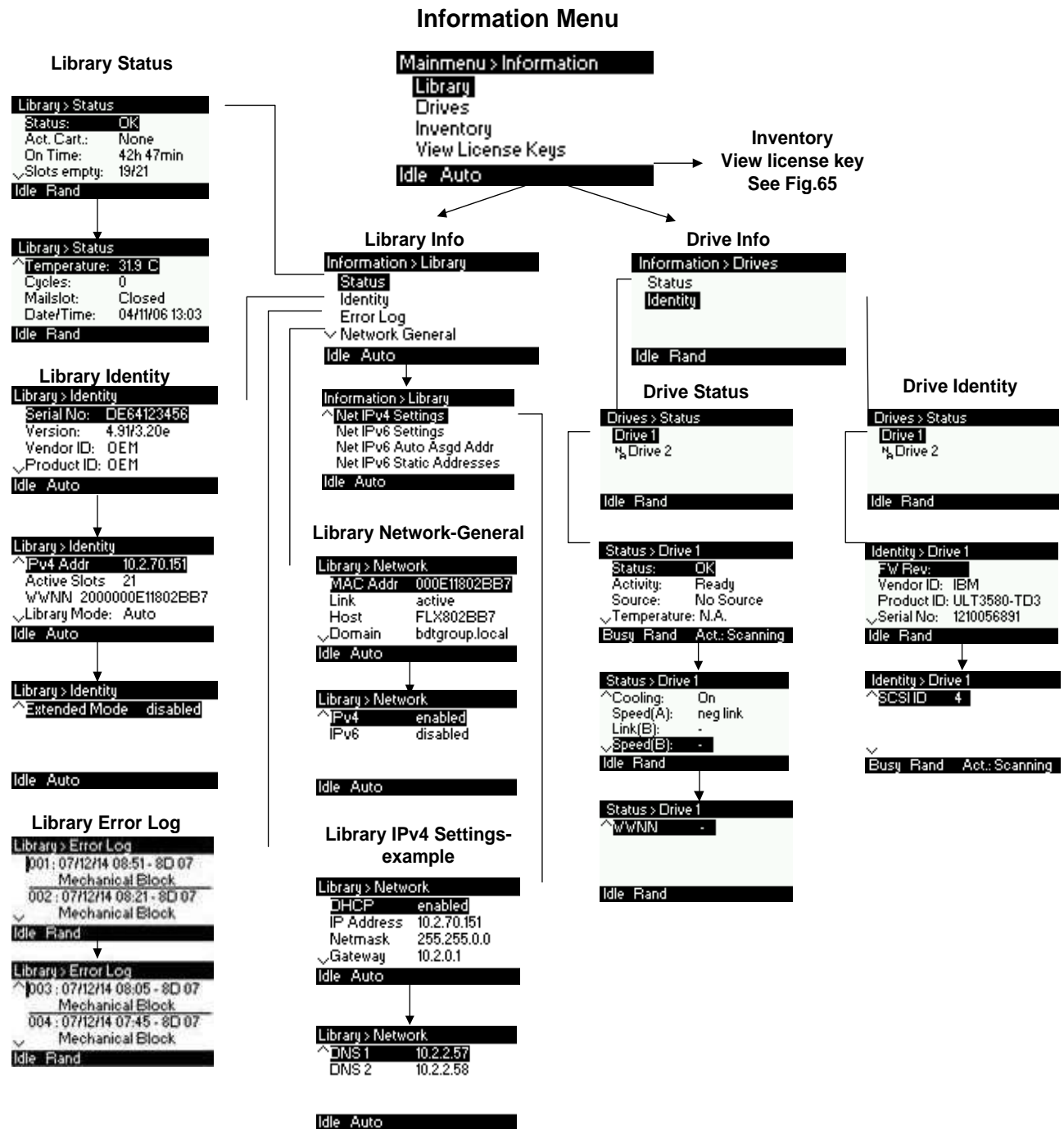

Figure 23 Information menu (1 of 2)

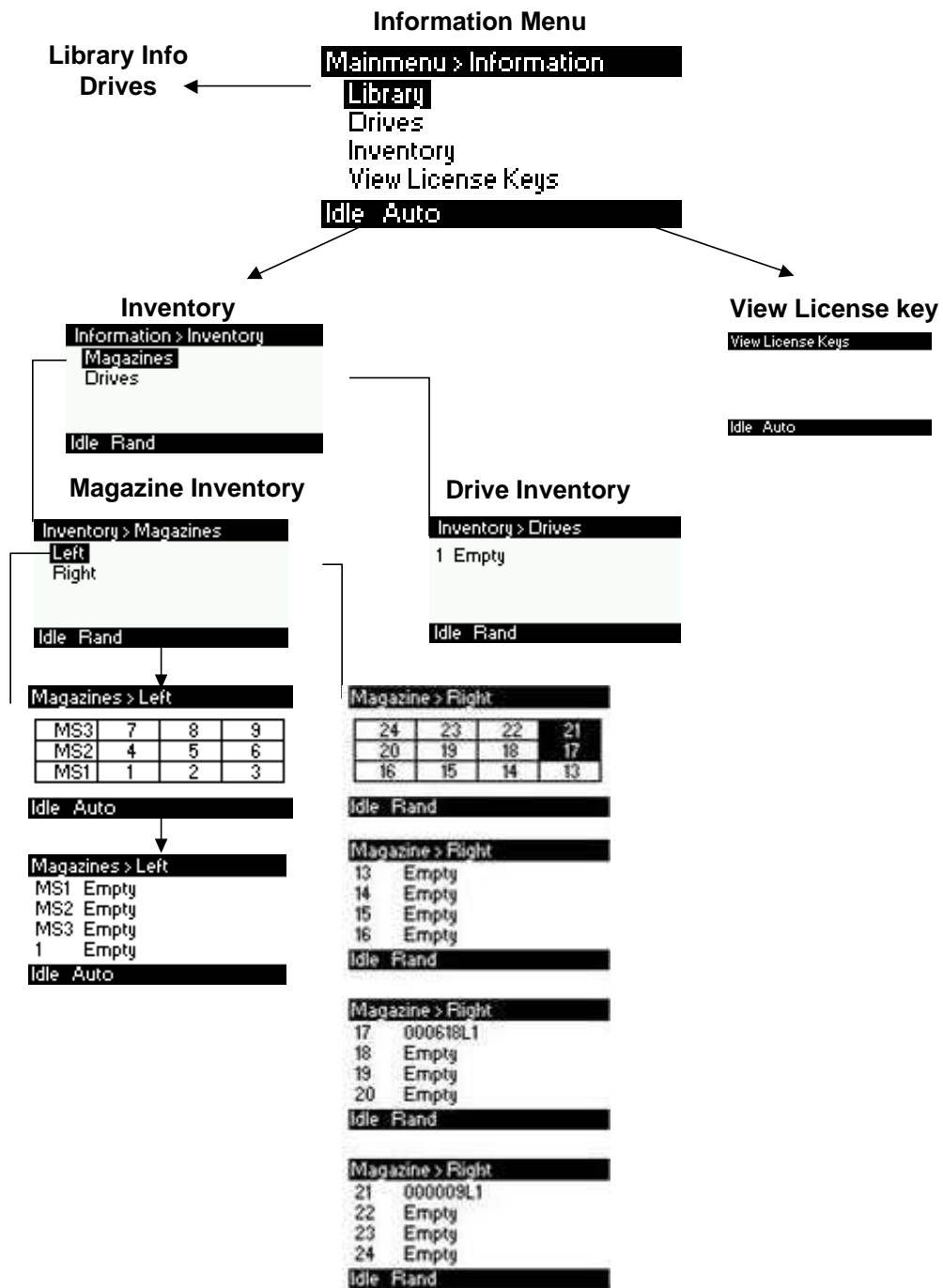

Figure 24 Information menu (2 of 2)

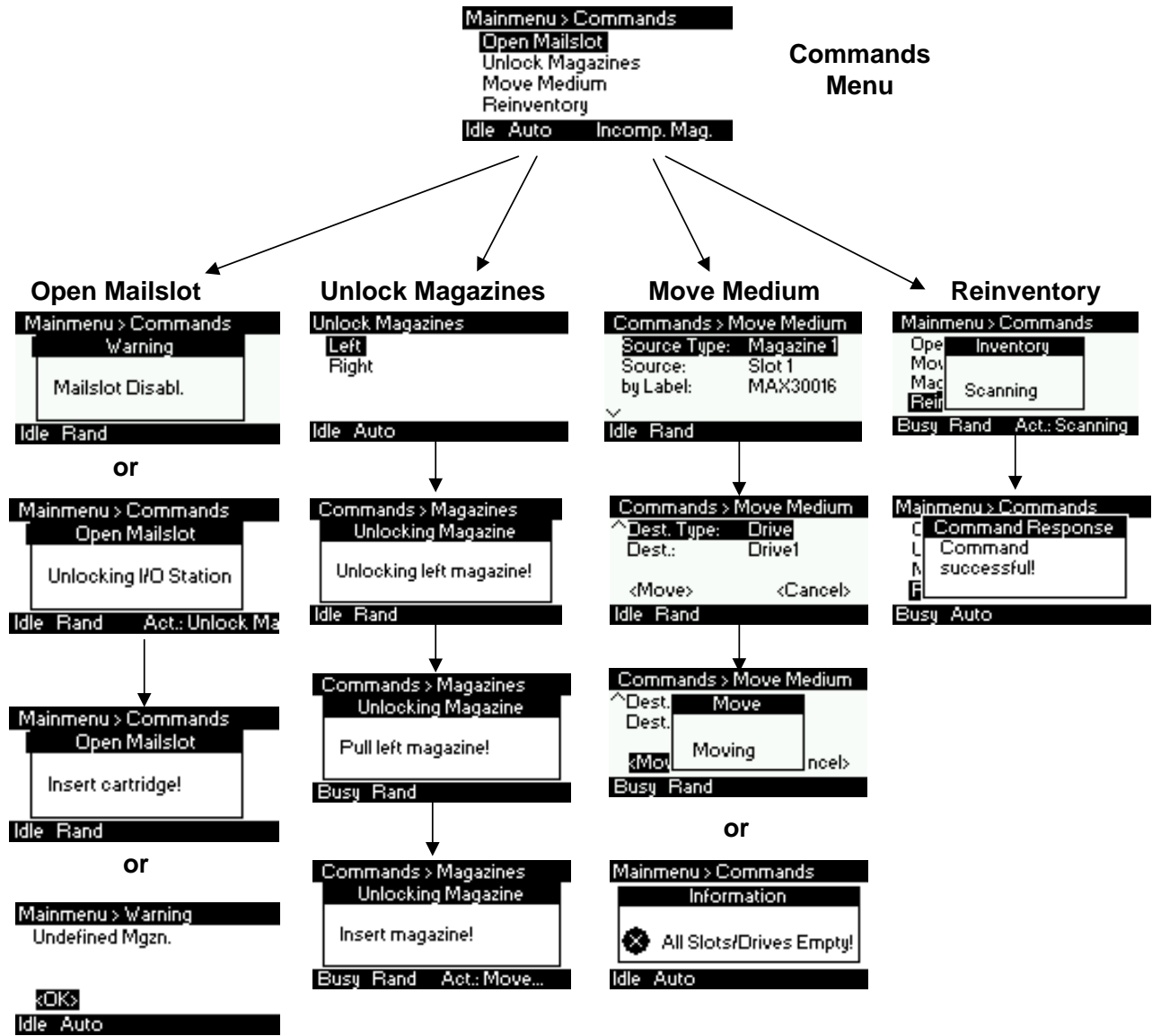

Figure 25 Commands menu

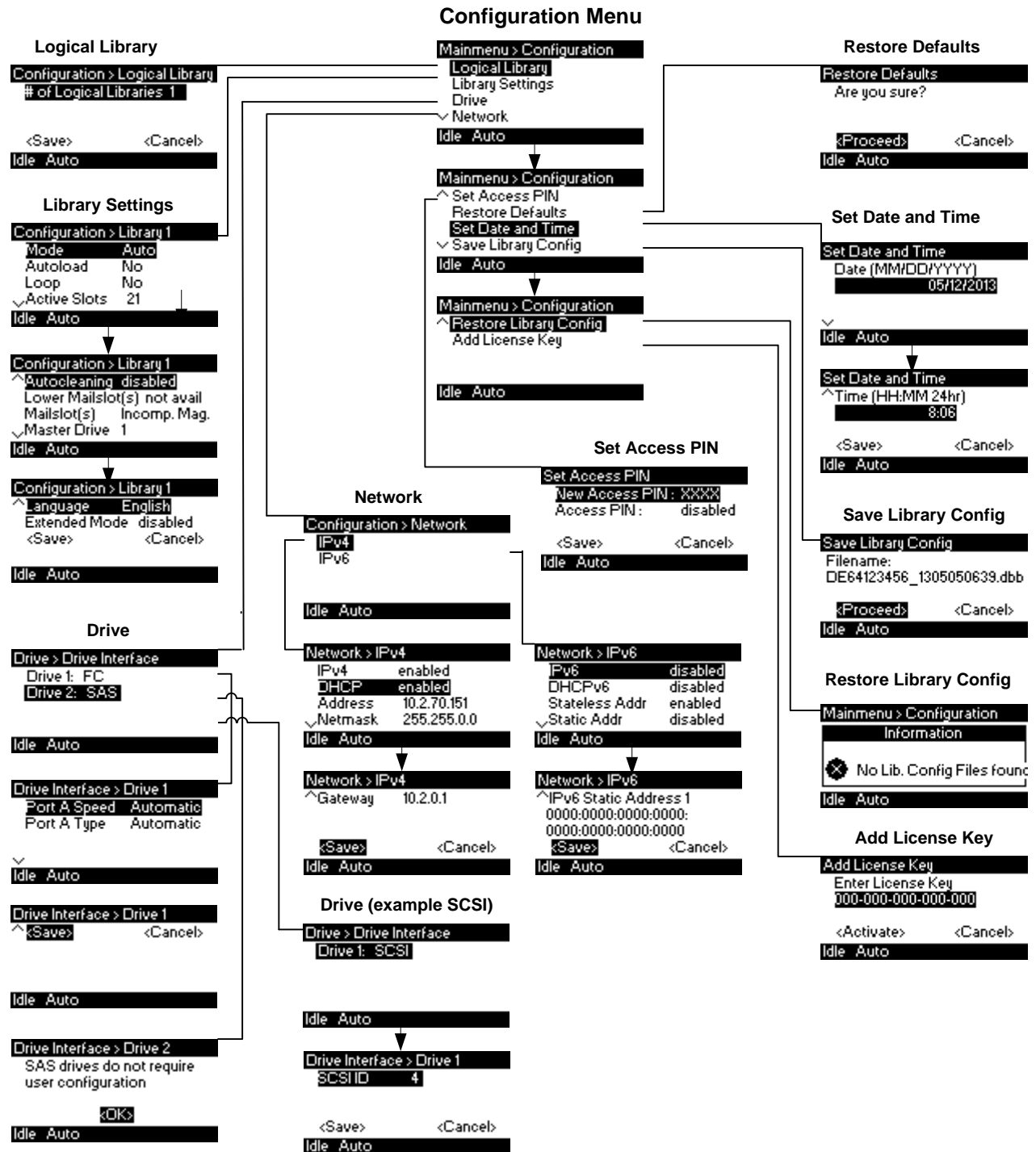

Figure 26 Configuration menu

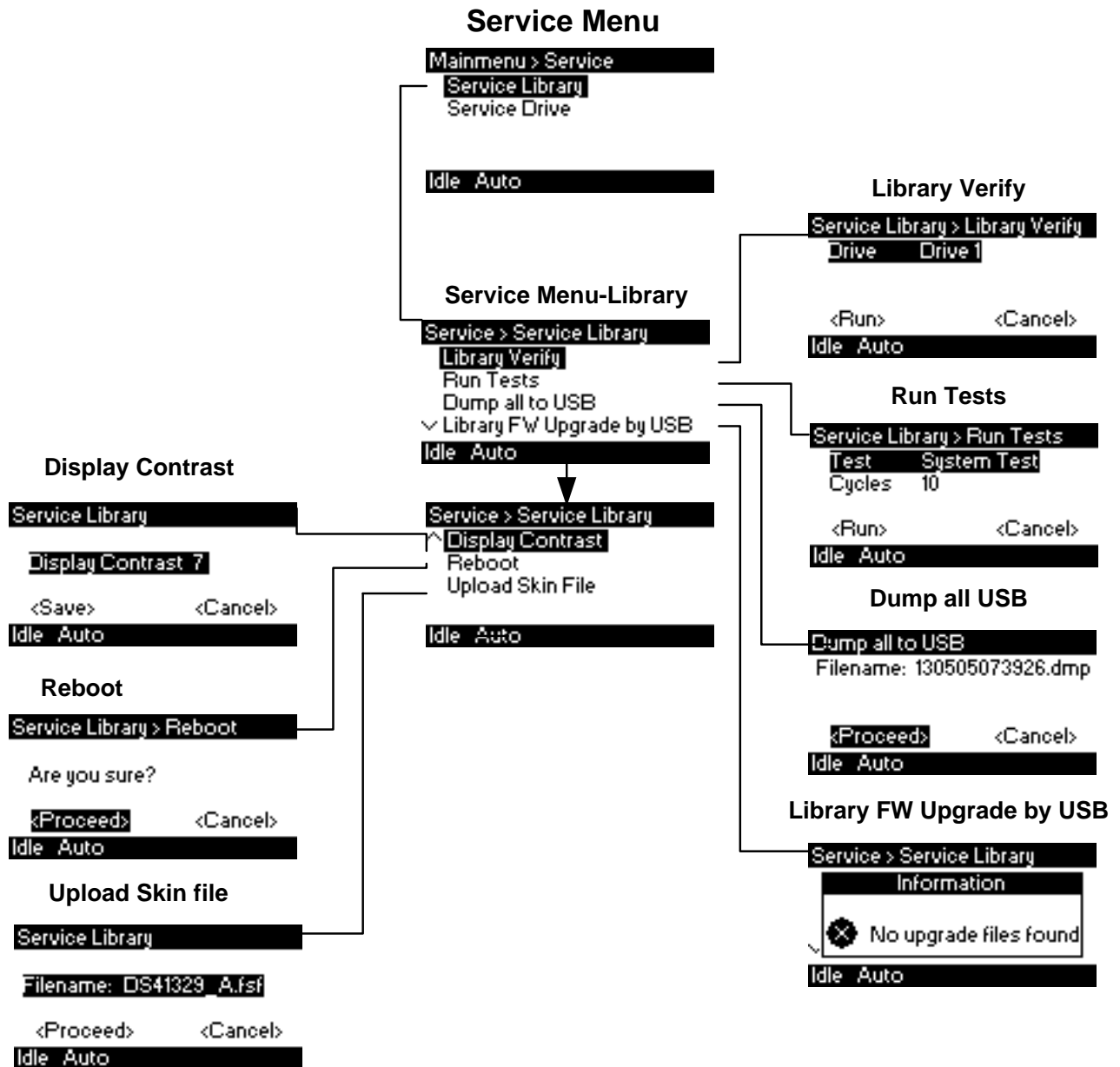

Figure 27 Service menu (1 of 2)

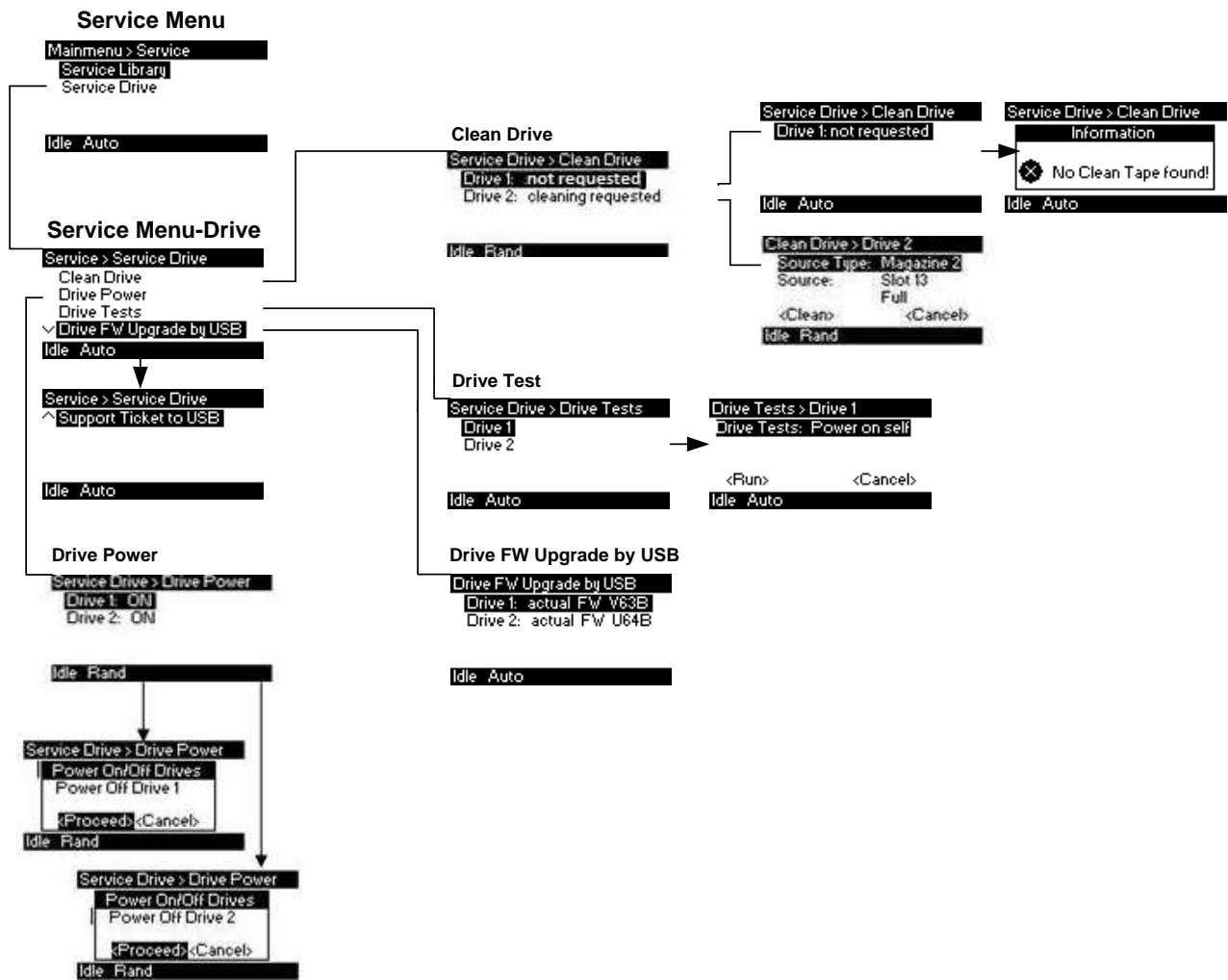

Figure 28 Service menu (2 of 2)

3.1.8

3.2 Remote management unit (RMU)

3.2.1 Overview

Many of the same operations performed locally from the operator control panel (OCP) can also be performed remotely using the network connected Remote Management Unit (RMU).

The RMU lets you monitor and control the library from any computer connected to your network or through the World Wide Web (WWW). The RMU hosts a dedicated, protected Internet site that displays a graphical representation of the library.

After establishing a network connection to the library, open any HTML browser and enter the IP address of the library. To allow access from the RMU, you must first set the desired static IP address at the OCP or configure to use DHCP.

3.2.2 Operations through the RMU

The following operations are available through the remote management unit as explained below:

1. Identity

- Viewing the static library identity
- Viewing the static drive identity
- Viewing the network identity

2. Status

- Viewing the dynamic library status
- Viewing the dynamic drive status
- Viewing the tape cartridge inventory

3. Configuration

- Changing the system configuration
- Changing the logical library configuration
- Setting the license key
- Changing the drive configuration
- Changing the network configuration
- Changing the SNMP configuration
- Changing the user password
- Setting date/time
- Setting error log mode
- Setting event for email notification parameters
- Restoring factory defaults

4. Operations

- Move media within the library
- Rescanning the media inventory
- Releasing magazines for removal

5. Service

- Performing a general diagnosis of the library
- Determining and updating firmware
- Reboot of the library
- Viewing library logs
- Cleaning tape drive(s)
- Cartridge memory

3.2.3 Login



NOTE

- Some options of the RMU take the library offline. This inactive mode can interfere with host-based application software, causing data loss. Make sure the library is idle before attempting to perform any remote operations that will take the library offline.

To login, select the access type and enter the correct password. There are three levels of access:

- Guest - (standard user level – default password **std001**).
- Admin - (administrator user level – default password **adm001**).
- Service - (service user level; for access by service personnel only – default password **ser001**).

Each level affects the areas to which you have access and what actions you can initiate in those areas.

Login

User:

Guest

Admin

Service

Password:

Sign In Clear

Figure 29 RMU Login

3.2.4 RMU Screen Layout

Once logged in, the general layout of all RMU screens is similar:

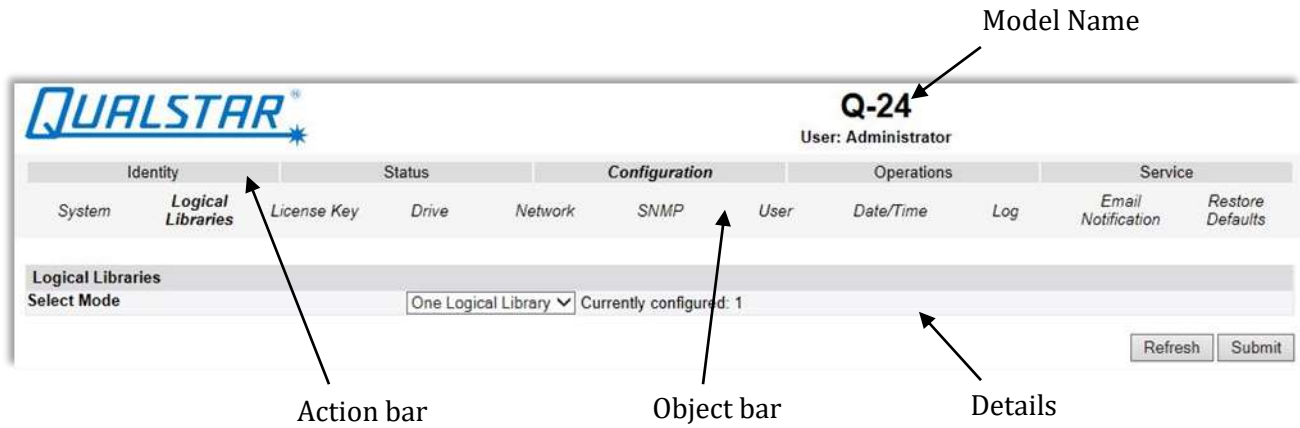

Figure 30 RMU Menu System

Menu items in the Action bar and Object bar are selectable, and the currently selected item is displayed in ***bold italics***. The items listed in the Action bar are fixed, but the items in the Object bar vary according to the action selected (see **Section 3.2.2** above). Similarly, the contents of the detailed information area shown below the two bars depend on the selected action and object.

At the right side of every screen, a summary of the system status is displayed and continually updated:



Figure 31 System Status summary

The status icons that may be displayed are as follows:



Symbol	Description for the status icons
	The green check mark for status <Ok> indicates that the library is fully operational and that no user intervention is required.
	The yellow exclamation point for status <Warning> indicates that user intervention is necessary, but that the library is still capable of performing operations.
	The red x for status <Error> indicates that user intervention is required and that the library is not capable of performing operations.

Table 4 Legend of status icons (RMU)

The information displayed is as follows:

- Date/Time
- Status = Overall library status
- Drive Status = Individual drive status (there will be one entry for each installed drive).
- Slots (Free/Total) = Total library slot capacity
- Mailslot = Open/Closed
- Library Time = Time stamp displayed in 24 hour format
- Auto Clean Status = If the Auto Clean Option is configured the status will be displayed here

3.2.5 Identity

3.2.5.1 Viewing the static library identity

This page provides access to the static information about the system. No changes can be made from this page.



QUALSTAR [®]		Q-24		
		User: Administrator		
Identity	Status	Configuration	Operations	Service
Library	Drive	Network		
Library Information				
Serial Number	DE65202382			
Product ID	FlexStor II			
Currently Installed Library Firmware	4.91 / 3.20e			
Bootcode Firmware Revision	0.60			
Barcode Reader	CSE600			
Library Mode	Manual, Random			
WWide Node Name	2000000E11802508			

Figure 32 Library identity

The following information is displayed:

1. Library information:
 - Serial Number
 - Product ID
 - Currently Installed Library Firmware
 - Boot code Firmware Revision
 - Barcode Reader
 - Library Mode
 - World Wide Node Name

2. Extended Logical Library information: If the unit has more than one partition, the properties of each logical library are displayed as above.

3.2.5.2 Viewing the static drive identity

This page provides access to the static information about the drive(s). No changes can be made from this page.

If two tape drives are installed in the library, the information will be shown by selecting the appropriate drive from the pull down menu.



Identity		Status	Configuration	Operations	Service
Library	Drive	Network			
Drive Information		1 (LUN)			
Vendor ID	IBM				
Product ID	ULT3580-HH5				
Serial Number	1068025981				
Firmware Revision	CB11				
World Wide ID - Port A	5000E11802508002				
World Wide ID - Port B	5000E11802508003				
Physical Drive Number	1				
Element Address	1				
Library Master Drive	Yes				
Data Compression	No				
Interface Type	SAS				

Figure 33 Drive identity

The following information is displayed:

1. Drive information:
 - Vendor ID = Drive manufacturer
 - Product ID = Model identification of the drive
 - Serial Number = Serial number of the drive
 - Firmware Revision = Operating firmware level of the drive
 - World Wide ID = Unique unit identifier of the drive
 - Physical Drive Number = Number indicating drive's physical position within the library
 - Element Address = Number indicating the logical identification of the drive
 - Library Master Drive = Indicates if library's logical interface is hosted by this drive
 - Data Compression = Indicates if drive hardware data compression is enabled
 - Interface Type (SAS or FC) = Indicates drive's physical interface connection type
2. Additional drive information (up to 4 half-height tape drives for the Q48)

3.2.5.3 Viewing the network identity

This page provides access to the network information about the connections of the library. No changes can be made from this page.

Identity		Status	Configuration	Operations	Service
Library	Drive	Network			
Network Information					
MAC Address				000E11802508	
Full Qualified Domain Name				FLX802508.qualstar.com	
IPv4 Addressing				Enabled	
IPv4 DNS Server 1				10.252.2.60	
IPv4 DNS Server 2				10.252.2.90	
DHCPv4 Addressing				Enabled	
IPv4 Address				10.252.2.113	
Subnet Mask				255.255.255.0	
Default Gateway				10.252.2.1	
IPv6 Addressing				Disabled	
SNMP				Disabled	
Email Notification				Disabled	
Clock Synchronization Configuration (SNTP)				Disabled	

Figure 34 Network identity

The following information is displayed:

- Network information:
 - MAC Address
 - Full Qualified Domain Name
 - IPv4 Addressing = Enabled/Disabled
 - IPv4 DNS Server 1 = IP address of domain name server 1
 - IPv4 DNS Server 2 = IP address of domain name server 2
 - DHCPv4 Addressing = Enabled/Disabled
 - IPv4 Address = IP address assigned by DHCP
 - Subnet Mask
 - Default Gateway = IP address of default gateway
 - IPv6 Addressing = Enabled/Disabled
 - SNMP = Enabled/Disabled
 - Email Notification = Enabled/Disabled
 - Clock Synchronization Configuration (SNTP) = Enabled/Disabled

3.2.6 Status

3.2.6.1 Viewing the dynamic library status

This page displays the dynamic information about the library, such as the current status of the components.

Identity	Status	Configuration	Operations	Service
<i>Library</i>	<i>Drive</i>	<i>Inventory</i>		
Library Status At 02:43:11 Library Time				
Status	Ready			
Cartridge In Transport	None			
Number Of Moves	863			
Total Power On Time	68d 11h 9min			
Robotic Status	Ready			
Internal Temperature	34.1 °C			
Left Magazine	Present			
Right Magazine	Present			

Figure 35 Library status

The following information is displayed:

1. Library status:

- Status = Indicates whether library is ready to accept commands
- Cartridge in Transport = Indicates whether the media changer contains a cartridge
- Number Of Moves (Odometer) = Indicates total number of moves made by the media changer
- Total Power On Time = Indicates total library power-on time
- Robotic Status = Indicates whether the media changer is ready to accept commands
- Internal Temperature = Indicates internal unit temperature in degrees centigrade
- Left/Right Magazine = Indicates presence or absence of tape magazines

3.2.6.2 Viewing the dynamic drive status

This page provides detailed information about all drives that are present in the library.

If multiple tape drives are installed in the library, the information will be shown by selecting it from the pull down menu.

Identity	Status	Configuration	Operations	Service
Library	Drive	Inventory		
Drive 1 Status At 02:43:51 Library Time				
Status	Ready			
Cartridge In Drive	None			
Drive Error Code	No Error			
Cooling Fan Active				
Drive Activity	Ready			
Port A Status	Ready, connected			
Speed	6 Gb/sec			
Hashed SAS address	DA19B8			
Port B Status	Not ready, not connected			
Speed	-			
Hashed SAS address	000000			

Refresh

Figure 36 Drive status

The following information is displayed:

1. Drive status:
 - Status = Indicates whether drive is ready for use
 - Cartridge in Drive = Indicates whether the drive contains a tape cartridge
 - Drive Error Code
 - Drive Temperature
 - Cooling Fan Active
 - Drive Activity
 - Drive Port = Information relevant to the specific drive interface (FC or SAS)
2. Additional drive information (up to 4 half-height tape drives for a Q48)

3.2.6.3 Viewing the tape cartridge inventory

This page provides detailed information about the tape inventory in the library. A summary of each magazine is shown. To get detailed information, click on the <+> button. This will expand the display for the specified magazine and provide detailed cartridge information.

Figure 37 Tape cartridge inventory (summary)

Slot #	Attn	Status	In Drive	Label	Media Loads	Comment
Mailslot	Closed	Empty		-----		
1		Full, Gen. 5		TRI092L5	101	Not Encrypted
2		Full, Gen. 5		TRI093L5	102	Not Encrypted
3		Full, Gen. 5		TRI094L5	108	Not Encrypted
4		Empty		-----		
5		Empty		-----		
6		Empty		-----		
7		Empty		-----		
8		Empty		-----		
9		Empty		-----		
10		Empty		-----		
11		Empty		-----		

Figure 38 Tape cartridge inventory (detail)

3.2.7 Configuration

3.2.7.1 Changing the System Configuration

This page allows the user to change the system configuration.

The screenshot shows the QUALSTAR Q-24 web interface. At the top, the logo and model name 'Q-24' are displayed, along with the user 'Administrator'. Below is a navigation menu with tabs: Identity, Status, Configuration, Operations, and Service. The 'Configuration' tab is selected, showing various settings:

- Library Master Drive:** A dropdown menu set to '1'.
- Library Mode:** Radio buttons for 'Random' (selected), 'Sequential', and 'Automatic'. Below are checkboxes for 'Autoload' and 'Loop'.
- Active Slots:** A dropdown menu set to '23'.
- Mailslot Enabled:** A checked checkbox.
- Auto Clean Enabled:** An unchecked checkbox.
- Select Language:** A dropdown menu set to 'English'.
- Enable Extended Mode:** An unchecked checkbox.

At the bottom right, there are 'Refresh' and 'Apply' buttons.

Figure 39 System Configuration

The following information is displayed:

1. **Library Master Drive:** The drive number that will host the library's logical unit number (LUN)
2. **Library Mode:** One of three behavior modes - Random, Sequential or Automatic
 - **<Random>** In random mode, the library does not automatically load tapes into the tape drives. The random mode is used with a full featured or a media changer-aware backup application and is the most common mode of operation.
 - **<Sequential>** In sequential mode, the library automatically loads and unloads tapes from the tape drive. The sequential mode is used when the backup software is not media changer-aware or was designed for standalone drives only.
 - **<Automatic>** This is the default mode. In automatic mode, the library switches from sequential mode into random mode when it receives library SCSI commands through its unique LUN.

In sequential mode, the user can set the <Loop> and <Autoload> options. In the auto load mode, the library automatically loads the tapes from the lowest-numbered full slot into the tape drive. In loop mode, the original first tape in the sequence is reloaded after the library has cycled through all available tapes.

3. **Active Slots:** In this field the user can select the number of slots in the library that are available to the backup software.

4. **Mailslot Enabled:** Enabling the mailslot in the library reduces the total number of available storage slots to the library's maximum slot count, less the number of mailbox slots.
5. **Auto Clean Enabled:** When auto clean is enabled, the library automatically loads a cleaning cartridge when a tape drive needs to be cleaned. The library identifies a tape as a cleaning tape if it has a bar code label that starting with CLN or after an unlabeled cleaning tape has been loaded into the tape drive.
6. **Select Language:** The select language menu allows the user to specify the language displayed by the RMU interface. The default display language is English. Possible alternate language selections are German, Italian, Spanish, and French. In order for the selection to take affect the desired language must be selected in the drop down menu and the apply button pushed. The web screen must then be refreshed.

Changes will only be applied after the <Refresh> or the <Apply> button is selected. After doing so, a warning page will inform the user of the impact of the proposed change. In some cases, a pop-up screen will ask the operator to confirm the change. Many changes will also require a reboot.

3.2.7.2 Configuring Logical Libraries

The logical libraries drop down allows the user to partition one library into smaller "logical libraries". Each logical library must contain at least one tape drive. For more information on this feature please see **Section 3.3, Partitioning the library**.

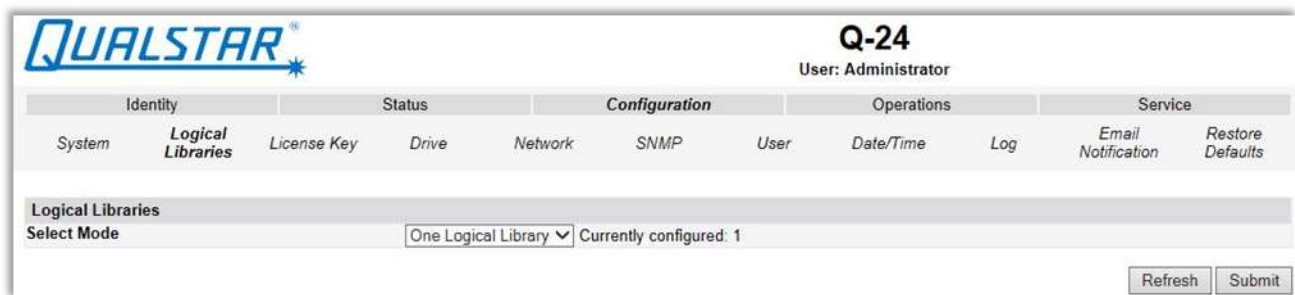

Figure 40 Logical Libraries

3.2.7.3 Changing the License Key configuration

This page allows the user to add additional functionality to the unit by entering license key information. Please contact your supplier to see if this functionality is applicable in your system.

The screenshot shows the QUALSTAR Q-24 web interface. At the top right, it says "Q-24 User: Administrator". Below this is a navigation menu with tabs: Identity, Status, Configuration, Operations, and Service. Under the Configuration tab, there are sub-tabs: System, Logical Libraries, License Key, Drive, Network, SNMP, User, Date/Time, Log, Email Notification, and Restore Defaults. The "License Key" sub-tab is selected. Below the navigation is a section titled "License Key" with a sub-section "Add new License Key" containing a text input field. At the bottom right of the page are "Refresh" and "Submit" buttons.

Figure 41 License key

3.2.7.4 Changing the Drive configuration

This page shows the current configuration of all tape drives in the library and allows modification to the configuration. The user is also able to select the <Power On> check box through this page to activate the drive.

The screenshot shows the QUALSTAR Q-24 web interface. At the top right, it says "Q-24 User: Administrator". Below this is a navigation menu with tabs: Identity, Status, Configuration, Operations, and Service. Under the Configuration tab, there are sub-tabs: System, Logical Libraries, License Key, Drive, Network, SNMP, User, Date/Time, Log, Email Notification, and Restore Defaults. The "Drive" sub-tab is selected. Below the navigation is a section titled "Drive Configuration" with a sub-section "Drive 1 (LUN)". Under "Drive 1 (LUN)", there is a checked checkbox for "Power On" and a note: "Note: SAS drives do not require user configuration". At the bottom right of the page are "Refresh" and "Submit" buttons.

Figure 42 Drive configuration

3.2.7.5 Changing the Network configuration

This page shows the current network configuration of the library related to the RMU access and allows modification to the configuration. When a change is requested, a pop-up window will ask you to confirm the changes.

**CAUTION**

- Changes in this menu may affect the ability to access the RMU interface unless the correct IP address is resolved.

QUALSTAR **Q-24**
User: Administrator

Identity		Status	Configuration		Operations	Service					
System	Logical Libraries	License Key	Drive	Network	SNMP	User	Date/Time	Log	Email Notification	Restore Defaults	
Network Configuration											
Host Name			<input type="text" value="FLX802508"/>								
Domain Name			<input type="text" value="qualstar.com"/>								
IPv4											
DHCP Address Enabled			<input checked="" type="checkbox"/>								
Static Address			<input type="text" value="10.252.2.113"/>								
Subnet Mask			<input type="text" value="255.255.255.0"/>								
Gateway address			<input type="text" value="10.252.2.1"/>								
IPv4 DNS Server 1			<input type="text" value="10.252.2.60"/>								
IPv4 DNS Server 2			<input type="text" value="10.252.2.90"/>								
IPv6											
IPv6 DNS Server 1			<input type="text" value="0.0.0.0.0.0.0.0"/>								
IPv6 DNS Server 2			<input type="text" value="0.0.0.0.0.0.0.0"/>								
Stateless Auto Config			<input checked="" type="checkbox"/>								
DHCPv6 Addressing			<input type="checkbox"/>								
Static Addressing			<input type="checkbox"/>								
Static Address			Please select a Prefix <input type="text"/> : <input type="text"/> <input type="button" value="Add"/>								
Enable SSL for Web			<input type="checkbox"/>								
A new login is required if changes are done! If the IP address changes, the new one must be entered in the address bar.										<input type="button" value="Refresh"/>	<input type="button" value="Submit"/>

Figure 43 Network configuration

Changes that can be made are:

- Host Name: In this box enter the name you wish to use to address this library in the future. It is recommended that you use a name that is relevant to its location and/or its purpose. The Host Name may be up to 15 characters long.
Allowed characters are: [A-Z], [a-z], [0-9], hyphen [-] and period [.]
Disallowed characters are: hyphen [-] as the first character, blanks or consecutive hyphens [-]
- Domain Name: In this box is the domain in which the library is registered. It may be updated by editing the name and submitting the changes. The Domain Name may be up to 39 chars long.
Allowed characters are: [A-Z], [a-z], [0-9], hyphen [-] and period [.]
Disallowed characters are: hyphen [-] as the first character, blanks or consecutive hyphens [-], blanks or consecutive hyphens [-] as the first or last character of a label (A period [.] is the delimiter of domain name labels!)

The sum of characters of the Host Name and the Domain Name may not exceed 15+39=54 chars.
- IPv4
 - DHCP Address Enabled - Used to set the RMU to seek an assigned IP address from the network's DHCP server.

- Static Address - This field is only active with DHCP address off (unchecked), a static IP address may be programmed in this field.
- Subnet Mask - Used to set the Network Mask, contact your Network administrator to receive this setting address if required.
- Gateway address - Used to set the Gateway Address; contact your Network administrator to receive this address if required (used when an IP address does not match any other routes in the routing table)
- IPv4 DNS Server 1 - This is the IP address of your name server (DNS server). A DNS server allows the library to communicate with other network clients via their host name. If you have a DNS Server on your network, enter the IP address in this field.
- IPv4 DNS Server 2 - This is the alternate IP address of your name server (DNS server). A DNS server allows the library to communicate with other network clients via their host name. If you have a DNS server on your network, enter the alternate IP address in this field.
- IPv6
 - IPv6 DNS Server 1 - This is the IP address of your name server (DNS server). A DNS server allows the library to communicate with other network clients via their host name. If you have a DNS Server on your network, enter the IP address in this field.
 - IPv6 DNS Server - This is the alternate IP address of your name server (DNS server). A DNS server allows the library to communicate with other network clients via their host name. If you have a DNS server on your network, enter the alternate IP address in this field.
 - Stateless Auto Configuration
 - DHCPv6 Addressing - Used to enable DHCP addressing assignment from the network name server
 - Static Addressing - Used to enable a static IP address for the RMU access
 - Static Address - Setting of the static IP address for the RMU
- Enable SSL for Web

3.2.7.6 Changing the SNMP settings

If a host and domain name is entered instead of an address, the IPv4 or IPv6 address will be resolved from the DNS using that name. The IP address will be stored in the library rather than the name. Therefore, if the address changes then the name or a new address will have to be entered.

QUALSTAR **Q-24**
User: Administrator

Identity		Status	Configuration		Operations	Service				
System	Logical Libraries	License Key	Drive	Network	SNMP	User	Date/Time	Log	Email Notification	Restore Defaults
SNMP Configuration										
SNMP Enabled		<input type="checkbox"/>								
IPv4 SNMP Target Addresses										
IPv4 Target 1	0.0.0.0	Version	SNMPv1	IPv4 address or Host name and domain *						
IPv4 Target 2	0.0.0.0	Version	SNMPv1	IPv4 address or Host name and domain *						
IPv4 Target 3	0.0.0.0	Version	SNMPv1	IPv4 address or Host name and domain *						
IPv6 SNMP Target Addresses										
IPv6 Target 1	0:0:0:0:0:0:0	Version	SNMPv1	IPv6 address or Host name and domain *						
IPv6 Target 2	0:0:0:0:0:0:0	Version	SNMPv1	IPv6 address or Host name and domain *						
IPv6 Target 3	0:0:0:0:0:0:0	Version	SNMPv1	IPv6 address or Host name and domain *						
Community Name	public									
Security User Name	initial									
SNMP Trap Notification Filter	<input type="radio"/> Critical Events <input type="radio"/> Critical and Warning Events <input type="radio"/> Critical, Warning and Configuration Events <input checked="" type="radio"/> Critical, Warning, Configuration and Informational Events <input type="radio"/> No Events									

* If a host and domain name are entered instead of an address, the IPv4 or IPv6 address will be resolved from the DNS using that name. That address will be stored in the library rather than the name. Therefore, if the address changes, then the name or a new address will have to be entered.

Refresh Submit

Figure 44 SNMP configuration

Changes that can be made are:

- SNMP Enabled/Disabled
- IPv4 SNMP Target Addresses
 - IPv4 Target 1
 - IPv4 Target 2
 - IPv4 Target 3
- IPv6 SNMP Target Addresses
 - IPv6 Target 1
 - IPv6 Target 2
 - IPv6 Target 3
- Community name
- Security User Name
- SNMP Trap Notification Filter
 - Critical Events
 - Critical and Warning Events
 - Critical, Warning and Configuration Events
 - Critical, Warning Configuration and Information Events
 - No Events

3.2.7.7 Changing the User settings

This page allows the user to add and modify user accounts.

The screenshot displays the QUALSTAR Q-24 user account settings interface. At the top, the QUALSTAR logo and 'Q-24' are visible, along with the user 'Administrator'. A navigation bar includes tabs for Identity, Status, Configuration, Operations, and Service. The Configuration tab is selected, showing a 'User Configuration' section with the following fields:

- Access Level:** A dropdown menu set to '2'.
- Access Level Name:** A text field containing 'admin'.
- New Password (Enter Up To Ten Characters):** A password field with ten dots.
- Repeat Password:** A password field with ten dots.
- OCP Access Pin Enabled:** An unchecked checkbox.
- OCP Access Pin Code:** A text field with four dots.
- Repeat OCP Access Pin Code:** A text field with four dots.
- Support Name:** A text input field.
- Support Phone:** A text input field.
- Support Email:** A text input field.

At the bottom right, there are 'Refresh' and 'Submit' buttons.

Figure 45 User account settings

Changes that can be made are:

- **Access Level:** Choose from 1 (Standard), 2 (Admin), or 3 (Service).
- **Access Level Name:** The name associated with the chosen access level.
- **New Password:** The password can be a maximum of ten characters.
- **Repeat Password:** Enter the new password again.
- **OCP Access PIN Enabled:** Select this item, if you would like the Operator Control Panel display to be password protected.
- **OCP Access PIN Code:** The password for accessing the OCP when the OCP Access PIN is enabled; max 4 characters
- **Repeat OCP Access PIN Code:** Enter the OCP Access PIN Code again.
- **Support Name:** The name of the individual within your company to contact for RMU or library support; max 30 characters
- **Support Phone:** The phone number of the individual within your company to contact for RMU or library support; max 30 characters
- **Support Email:** The email address of the individual within your company to contact for RMU or library support; max 30 characters

3.2.7.8 Setting Date/Time

This page allows the user to set the time and date, and how it will be displayed.

Figure 46 Date/time settings

Changes that can be made are:

Clock Configuration

- Time (24 hour format): hh:mm:ss
- Date: MM:DD:YYYY
- Clock Synchronization Configuration (SNTP):
 - Enable Clock Synchronization: If checked the unit will attempt to synchronize its clock with an external time source. The following apply:
 - SNTP Server Address (IPv4): This is the IP address of the network SNTP time server, the address may be a maximum of 40 characters.
 - UTC Time Zone Offset: This drop down menu allows the administrator to select the appropriate time zone offset so that the time will be displayed in the actual local time.
 - Daylight Saving Enabled: Provides for automatic offset of daylight savings time.

3.2.7.9 Setting Error Log mode



NOTE

- Only service personnel can set the log configuration.

The Log menu can be used to set behavior of the error log collection. Your service person may ask you to alter settings in this field during the diagnostic process. The default setting is for continuous collection of logs, with the most recent events overwriting the oldest events (circular buffer).

QUALSTAR **Q-24**
User: Administrator

Identity		Status	Configuration			Operations		Service		
System	Logical Libraries	License Key	Drive	Network	SNMP	User	Date/Time	Log	Email Notification	Restore Defaults

Log Configuration

Error Log Mode: Off Continuous Stop Trace At First Error

Trace Level:

- Cmd Response Event
- Trace Data Low Level Trace Recovered Error
- Hard Error

Trace Filter:

- Main Drive CDB Interpreter
- Robotic Trace OCP Input
- OCP Output SCSI Module SDCI Module

Figure 47 Error Log mode

Selections available are:

- Error Log Mode
- Trace Level
- Trace Filter

3.2.7.10 Configuring event parameters for Email Notification

This page allows the user to modify the event notification parameters.

QUALSTAR **Q-24**
User: Administrator

Identity		Status	Configuration			Operations		Service		
System	Logical Libraries	License Key	Drive	Network	SNMP	User	Date/Time	Log	Email Notification	Restore Defaults

Event Notification Configuration

Notification Level:

- Critical Events
- Critical and Warning Events
- Critical, Warning and Configuration Events
- No Events

To Email Address:

SMTP Server Address (IPv4): IPv4 address or Host name and domain *

* If a host and domain name are entered instead of an address, the IPv4 or IPv6 address will be resolved from the DNS using that name. That address will be stored in the library rather than the name. Therefore, if the address changes, then the name or a new address will have to be entered.

Figure 48 Event parameters for Email Notification

Changes that can be made are:

- Notification Level: Critical / Warning / Configuration events / none
- To Email Address: max 40 characters

- SMTP Server Address: IPv4 address or Host name and domain

3.2.7.11 Restoring factory Defaults

This page allows the user to reset the configuration to the factory defaults, and save or restore vital product data.

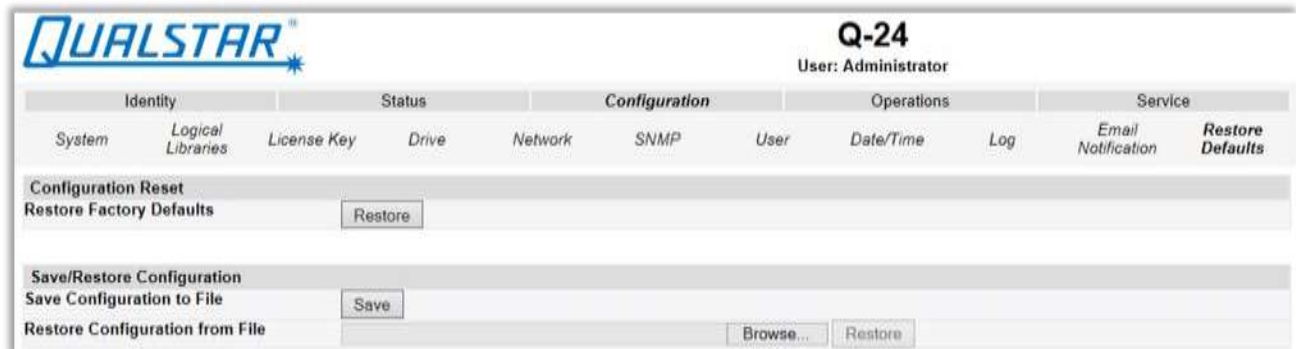

Figure 49 Factory defaults

Selections available are:

Configuration Reset

- <Restore> factory defaults: Selection of this button will restore all factory default settings as outlined in **Section 3.4**. Please note that OEM library applications may require operational settings which differ from the factory default settings. Please consult your system vendor to verify proper operational settings of the unit after a restore to factory defaults.

Save/Restore Configuration

- <Save> Configuration to File: The <Save> button will save the current library settings to a file which can later be uploaded back to the library to restore the settings. Library configuration files have a ".dbb" file extension with a file name format structure consisting of the unique 10 character library unit serial number followed by a space, followed by a date time stamp formatted "YYMMDDTTTT" (YY= last two digits of current year, MM = month number, DD = date, TTTT= Hour/minute time stamp (24 hour time format)).
- <Restore> Configuration from File: The <Browse> / <Restore> buttons enable the administrator to select a path to a previously generated configuration file. Once the correct file is located the <Restore> button is used to upload the file back to the library.

3.2.8 Operations

3.2.8.1 Move Media within the library

This page allows the user to move tape cartridges within the library.

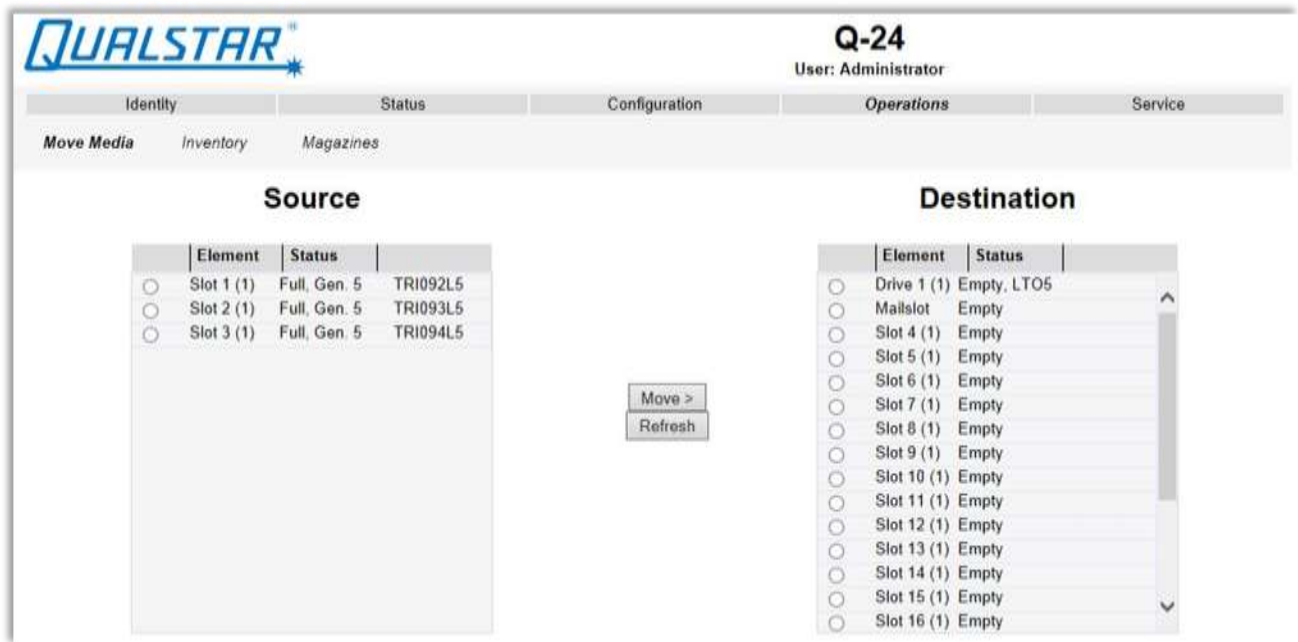

Figure 50 Move media

Select the source and destination and then click the <Move> button to move a tape cartridge.

3.2.8.2 Determining current media Inventory

This page allows the user to rescan the library to determine the current media inventory.



Figure 51 Media Inventory

Changes will only be applied after the <Rescan> button is selected.

3.2.8.3 Releasing and replacing Magazines

This page allows the user to release the right or left magazine from the library.



Figure 52 Release magazines

Select the magazine in the pull down menu and then click the <Release> button.



NOTE

- To release a magazine manually, see **Section 4.4**. This manual process should only be used if the magazine cannot be released using the OCP or the RMU.

3.2.9 Service

3.2.9.1 Performing General library Diagnostics

This page provides the system administrator with general tests to verify the usability and reliability of the library.

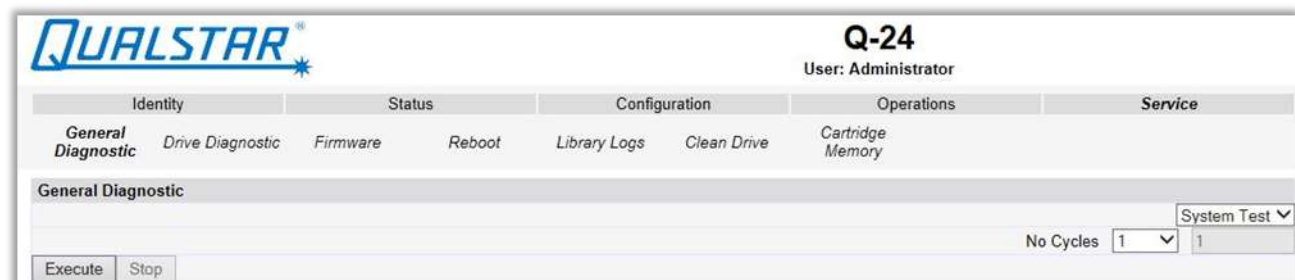

Figure 53 Library diagnostics

Selections available are:

- System Test
- Slot To Slot Test

Select the number of test cycles (No. Cycles) before starting the test. To cancel the test before it completes, select the <Stop> button.

3.2.9.2 Performing Drive Diagnostics

This page provides the system administrator with general tests to verify the usability and reliability of the drive(s).

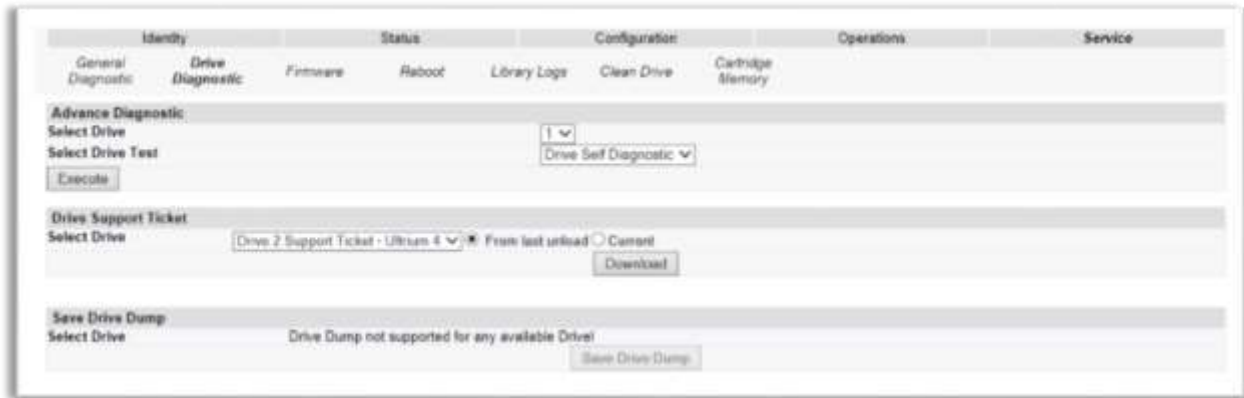

Figure 54 Drive diagnostics

Selections available are:

- Advance Diagnostic: Select Drive# and Select the Drive Test to be performed
- Drive Support Ticket: Select Drive# and choose last/current unload
- Save Drive Dump: Select Drive and click Save Drive Dump

3.2.9.3 Determining and updating firmware

This page displays the current versions of the library firmware and drive(s) firmware. New firmware can be uploaded to the library or a drive by using this page. After a firmware update, the system restarts automatically.



Figure 55 Firmware updates

3.2.9.4 Reboot of the library

**NOTE**

Ensure that the library is idle before attempting to perform any remote operations that will take it offline.

- Some options of the RMU take the library offline. This inactive mode can interfere with host-based application software, causing data loss.

This page is used to perform a library reboot. During a reboot, the RMU's connection to the library may be lost, depending on the timing of the reboot. This is because the RMU web page refreshes itself at intervals defined by a default time delay. If the reboot completes successfully during this delay, the connection will remain intact. If not, the user will have to restart the RMU login.



Figure 56 Reboot the library

3.2.9.5 Viewing Library Logs

This page allows the user to view the library logs.

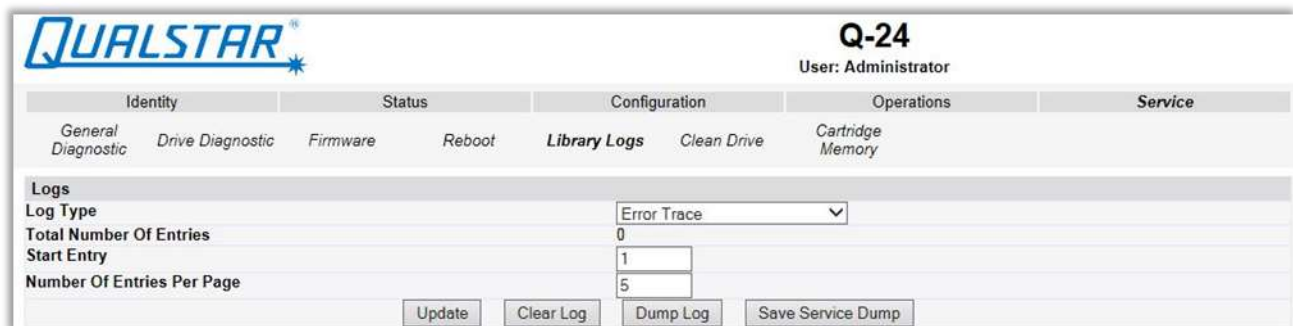

Figure 57 Library logs

The user can specify the following information:

- Log Type:
 - Error Trace
 - Informational Trace
 - Warning Trace
 - Configuration Change Trace
 - Standard Trace
- Start Entry
- Number Of Entries Per Page

Changes will only be applied after the <Update> or <Clear Log> button is selected.
<Dump log> creates the log and <Save Service Dump> allows the direct viewing or saving of the file.

3.2.9.6 Cleaning tape drive(s)

This page allows the user to initiate the tape drive cleaning process, if required.



The screenshot shows the QUALSTAR Q-24 web interface. At the top left is the QUALSTAR logo. At the top right, it says "Q-24" and "User: Administrator". Below this is a navigation menu with tabs: Identity, Status, Configuration, Operations, and Service. Under the Identity tab, there are sub-tabs: General Diagnostic, Drive Diagnostic, Firmware, Reboot, Library Logs, Clean Drive, and Cartridge Memory. The "Clean Drive" sub-tab is selected. Below the navigation is a "Clean Drive" section. It contains a "Slot #" field with the value "N.A." and a "Drive" field with a dropdown menu showing "1 - No Cleaning Required". A "Clean" button is located to the right of the dropdown menu.

Figure 58 Clean a tape drive

Select the magazine slot number containing the cleaning cartridge and the tape drive to be cleaned in the appropriate pull down menu and then click the <Clean> button.

3.2.9.7 Cartridge Memory

Provides details of the tapes stored in the library.

QUALSTAR **Q-24**
User: Administrator

Identity		Status		Configuration		Operations		Service		
<i>General Diagnostic</i>	<i>Drive Diagnostic</i>	<i>Firmware</i>	<i>Reboot</i>	<i>Library Logs</i>	<i>Clean Drive</i>	Cartridge Memory				
Slot	Elem ID	Vol Name	Loads	Cart Man	Cart S/N	Last Drv Vendor	Last Drv S/N	MB WR	MB RD	TAF
Mailslot 1	0 - 101	Empty								
1	0 - 1001	TRI092L5	101	HP	IC1PCIH595	IBM	6868025981	0	0	
2	0 - 1002	TRI093L5	102	HP	IC1PCI2546	IBM	6868025981	0	0	
3	0 - 1003	TRI094L5	108	HP	IC1PCIh613	IBM	6868025981	0	0	
4	0 - 1004	Empty								
5	0 - 1005	Empty								
6	0 - 1006	Empty								
7	0 - 1007	Empty								
8	0 - 1008	Empty								
9	0 - 1009	Empty								
10	0 - 1010	Empty								
11	0 - 1011	Empty								
12	0 - 1012	Empty								
13	0 - 1013	Empty								
14	0 - 1014	Empty								
15	0 - 1015	Empty								
16	0 - 1016	Empty								
17	0 - 1017	Empty								
18	0 - 1018	Empty								
19	0 - 1019	Empty								
20	0 - 1020	Empty								
21	0 - 1021	Empty								
22	0 - 1022	Empty								
23	0 - 1023	Empty								

Refresh Dump

Figure 59 Cartridge Memory

3.3 Partitioning the library

The Q24/Q48 Tape Library may be addressed either as a single 'logical library', or it may be partitioned into logical libraries. In the case of the Q24, two half-height tape drives must be installed and the library may be set to a maximum of two partitions, because each drive is fully dedicated to a single partition. Similarly, each 12-slot magazine is fully dedicated to a single partition. (Note however, that a single partition may include multiple magazines and multiple drives.) The Q48 may be partitioned up to a maximum of four partitions (each requiring a dedicated tape drive).

3.3.1 Q24 Single partition configuration

- Tape drive 1: half-height drive (default element addresses = 256)
- Tape drive 2: half-height drive (default element addresses = 257)
- Magazines: #1 and #2

3.3.2 Q24 Dual partition configuration

Partition 1

- Tape drive 1: half-height drive (default element address = 256)
- Magazines: #1

Partition 2

- Tape drive 2: half-height drive (default element address = 256)
- Magazines: #2

The mailslot (if configured as MAIL) will be shared between the logical libraries.

3.3.3 Q48 Single partition configuration

- Tape drive 1: half-height drive (default element addresses = 256)
- Tape drive 2: half-height drive (default element addresses = 257)
- Tape drive 3: half-height drive (default element addresses = 258)
- Tape drive 4: half-height drive (default element addresses = 259)
- Magazines: #1 through #4

3.3.4 Q48 Dual partition configuration

Partition 1

- Tape drive 1: half-height drive (default element address = 256)
- Tape drive 2: half-height drive (default element address = 257)
- Magazines: #1 and #2

Partition 2

- Tape drive 3: half-height drive (default element address = 256)
- Tape drive 4: half-height drive (default element address = 257)
- Magazines: #3 and #4

The mailslot (if configured as MAIL) will be shared between the logical libraries.

3.3.5 Q48 Three partition configuration

Partition 1

- Tape drive 1: half-height drive (default element address = 256)
- Magazines: #1

Partition 2

- Tape drive 2: half-height drive (default element address = 256)
- Magazines: #2

Partition 3

- Tape drive 3: half-height drive (default element address = 256)
- Tape drive 4: half-height drive (default element address = 257)
- Magazines: #3 and #4

The mailslot (if configured as MAIL) will be shared between the logical libraries.

3.3.6 Q48 Four partition configuration

Partition 1

- Tape drive 1: half-height drive (default element address = 256)
- Magazines: #1

Partition 2

- Tape drive 2: half-height drive (default element address = 256)
- Magazines: #2

Partition 3

- Tape drive 3: half-height drive (default element address = 256)
- Magazines: #3

Partition 3

- Tape drive 4: half-height drive (default element address = 256)
- Magazines: #4

The mailslot (if configured as MAIL) will be shared between the logical libraries.

**NOTE**

- The SCSI element addresses shown above are the default values which are valid in a new library or after a “Reset to Default”. They can be changed by SCSI SMC command.
-

Removed Drives

If a drive is physically removed, it is reported to the host application by reference to its SCSI element address. It is reported as ‘not accessible’ until it is inserted again in the drive slot and either:

- A “Reset to Default” from any user-interface occurs, or
- The logical library configuration changes (adding/removing of libraries)

3.4 Default settings

Setting	Default for the library
Initial admin password	adm001
Host name	FLX + last 6 characters of MAC address e.g. MAC = 000E11801907, host name = FLX801907
Domain name	<i>localdomain.com</i>
IPv4	Enabled
IPv6	Disabled
DHCP	Disabled
Mailslot configuration	Disabled
Configure reserved slots	Reserved slots = 0
SCSI master drive	The lowest physical drive is initially the LUN master drive.
OCP contrast setting	10
Library Mode	Automatic
Auto load	Disabled
Loop	Disabled
Drive power <ON/OFF>	All drives are powered <ON>
Auto clean	Disabled
SNMP	Disabled
FC tape drives	Automatic speed, auto topology
Log Tracing Configuration	All selected
Email notification	No events
Partitioning	Partitioning is turned <OFF>

Table 5 Default settings

4 Troubleshooting

This section provides information for verifying correct installation of your Q24/Q48 Tape Library and troubleshooting any issues that might arise with it.

4.1 Installation problems

Problems encountered during the installation of the library are usually caused by cabling issues, application software configuration errors, or an incorrectly configured operating system. If the host application software is not communicating with the library after installation, check the following:

4.1.1 Cabling

Check that all cables to the Q24/Q48, including power, SAS and/or Fibre Channel, as well as Ethernet and USB (if present) are properly seated in their respective sockets at both ends, and that the Q24/Q48 is powered on. If so, and the host is still not communicating successfully with the library, then the cables themselves may need to be checked. If spare cables are available, this can be achieved by replacing one cable at a time and assessing whether the problem is cured as a result. Note that power may be left on while exchanging any of the data cables, as their removal and replacement will not cause damage to the library.

4.1.2 Compatibility

Ensure that the library is compatible with the backup application you plan to use. For a list of compatible application software, check with your backup application vendor.

4.1.3 Backup application installation

Refer to the documentation included with your backup application for instructions on how to verify proper installation. Some backup software packages require an additional module to communicate with the library media changer.

4.1.4 Device driver installation

Make sure that the proper device driver, if applicable, is installed for the library. Contact your support representative for more information

**NOTE**

- Many backup applications use their own drivers for the library and tape drive. Before installing a driver, make sure it will not be in conflict with the software.
-

4.2 Troubleshooting

PROBLEM	SOLUTION
Poor throughput performance	
	<ul style="list-style-type: none"> ▪ Try a new tape. A marginal tape can cause performance problems due to bad spots on the tape requiring retries. ▪ Backing up data that compresses poorly or is already compressed will lower performance. ▪ Check the size of the files. Small file size can impact performance. ▪ Confirm that the backup application is utilizing block sizes of at least 32KB, preferably 64KB. Refer to the backup application documentation for details. ▪ Check the network bandwidth from the host computer. If you are backing up data over a network, consider comparing to a local-only backup. ▪ Make sure the backup server has enough memory to handle the bandwidth of the backup or restore. ▪ Clean the tape drive using: <ul style="list-style-type: none"> - OCP, see Section 3.1.7 - RMU, see Section 3.2.9.6
Cleaning	
Cannot load the cleaning cartridge	<ul style="list-style-type: none"> ▪ Make sure you are using an Ultrium universal cleaning cartridge. ▪ Contact your service representative.
Errors Displayed on Operator Control Panel	
"!" in library operator panel inventory display	Export the tape cartridge marked with an "!" in the inventory. The tape cartridge is either damaged, incompatible with the tape drive, or the wrong type for the attempted operation. To find the compatible tape cartridges for your library, see Section 2.15, Tape cartridges
There is an error code on the LCD	Look up the error code, try to resolve the failure, and cycle the power. See Section 4.7, Error codes .

PROBLEM	SOLUTION
Media	
Cleaning or data tape incompatible with drive.	<ul style="list-style-type: none"> ▪ Make sure you are using data and cleaning tapes that are compatible with the drive and model of your library. The library automatically unloads incompatible tapes, the <Media Attention> LED flashes, and an exclamation mark (!) is displayed in the inventory display for the indicated slot number. ▪ Export the media in order to clear the state.
Cannot write to or read from tape.	<ul style="list-style-type: none"> ▪ Make sure that the tape is write enabled (move the write-protect switch to the enabled position). ▪ Make sure you have the appropriate data tape for your library model. ▪ Make sure you are using an Ultrium tape that has not been degaussed. Do not degauss Ultrium tapes. ▪ Make sure that the tape has not been exposed to harsh environmental or electrical conditions and is not physically damaged in any way. ▪ Many backup applications do not read or write to tapes that were created using a different backup application. In this case, perform an erase, format, or label operation on the tape. ▪ Make sure you understand any data protection or overwrite protection schemes that your backup application may be using, which could prevent you from writing to a given tape. ▪ Retry the operation with a different, known good tape. ▪ Clean the tape drive using: <ul style="list-style-type: none"> - OCP, see Section 3.1.7 - RMU, see Section 3.2.9.6
Power	
Library does not power up.	<ul style="list-style-type: none"> ▪ Check all power cord connections. ▪ Make sure the power switch on the front panel is in the <ON> position. ▪ Make sure there is power to the outlet. Try another working outlet. ▪ Replace the power cord. ▪ Contact your service representative.
No display messages appear.	<ul style="list-style-type: none"> ▪ Make sure the power cord is connected. ▪ Make sure the power switch is on. ▪ Power cycle the library. ▪ Download the library firmware. ▪ Contact your service representative.

PROBLEM	SOLUTION
<Media Attention> LED issues	
Contamination by loose debris.	Avoid contamination by ensuring that the library is installed in a clean, contamination-free environment. Tapes should be stored vertically in their plastic cases. Clean the tape drive(s) as needed.
Non-acclimated media.	A tape should be acclimated for at least 24 hours before being used, particularly if it has been stored at a substantially different temperature or level of humidity than the library.
Tape cartridge is incompatible.	Use only tapes that are compatible with the tape drive type. See Section 2.15
Expired cleaning cartridge.	Make sure you are using an Ultrium universal cleaning tape. (max. 50 cleans)
Bad/defective/contaminated media.	<p>If the <Media Attention> LED is cleared and the tape drive is clean, but the LED immediately re-displays each time a particular tape is loaded, that tape should be suspected of being defective.</p> <ul style="list-style-type: none"> ▪ Export the tape and load a known good tape. In some cases, a tape can be worn out, have a defective tape memory, or have been formatted as a Firmware Upgrade Cartridge. ▪ Any tape that is suspected of being defective or contaminated should NOT be reused in any drive.
Tape cartridge movement	
Tape cartridge stuck in tape drive.	<ul style="list-style-type: none"> ▪ Power cycle the library, allow it to complete initialization, which in rare cases can take as long as 10 minutes, and then retry unloading the tape using the library operator control panel. ▪ Allow the tape drive to complete all operations. This may take as long as ten minutes if you reset or cycle power to the library while the cartridge is positioned at the physical end of the media. ▪ Make sure that the backup software is not reserving the slot or preventing the tape drive from ejecting the tape. The backup software needs to cancel the reservation and any hold it has on the tape drive. Temporarily disconnecting the library from the host server and power cycling eliminates the host and its software as a problem source. ▪ Contact your service representative.
Tape stuck in storage slot.	See Section 4.3

Table 6 Troubleshooting

4.3 Removing tape cartridges from the library



WARNING

Tape cartridges stuck in the Q24/Q48 Tape Library – Risk of damaging devices

- When the library is moved, any tape cartridge can become dislodged from the magazines and can damage other tape cartridges left in the library and the library media handler.
- To avoid damage, remove all tape cartridges before moving the library.

To remove a stuck tape cartridge, follow these steps:

1. Unlock the magazine using the:
 - OCP, see **Section 3.1.7**
 - RMU, see **Section 3.2.8.3**
 - Emergency release, if you are not able to unlock the magazine with the OCP or RMU, see **Section 4.4**
2. Pull the mailslot or magazine out to access the tape cartridge.
3. To remove the tape cartridge:
 - Use the finger holes to push the tape out of the slot.
 - If required insert a new tape cartridge.
 - Repeat this process until all stuck tape cartridges are removed.

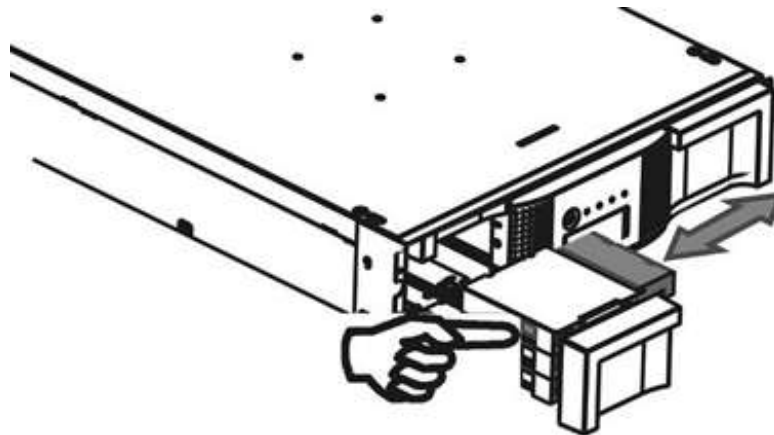

Figure 60 Removing a stuck tape

4. Push the mailslot or magazine back into the library.

4.4 Emergency release

If you cannot remove the magazines via the OCP or RMU, do the following:

1. Press the power button on the front bezel to power down the library.
2. Unplug the power cord from the library.
3. From the rear panel of the library, find the access holes for the right and left magazines.

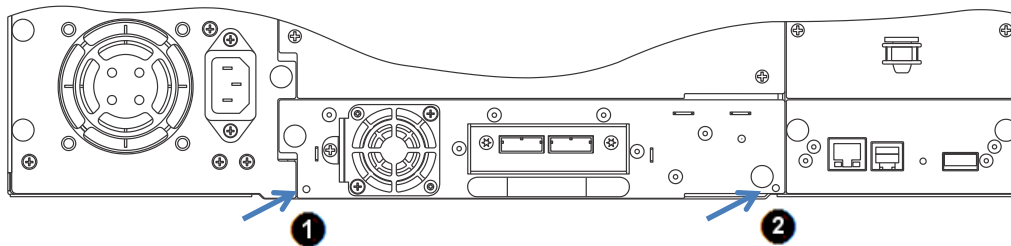

1 - Access hole for the right magazine

2 - Access hole for the left magazine

Figure 61 Rear panel (access holes)

4. Push the end of a small metal pin or straightened paper clip into the magazine access hole at the back of the device. While holding the pin or clip, have a second person attempt to pull the magazine out of the front of the unit.

For the Q48, all magazines on a side are release and should be removed at the same time.

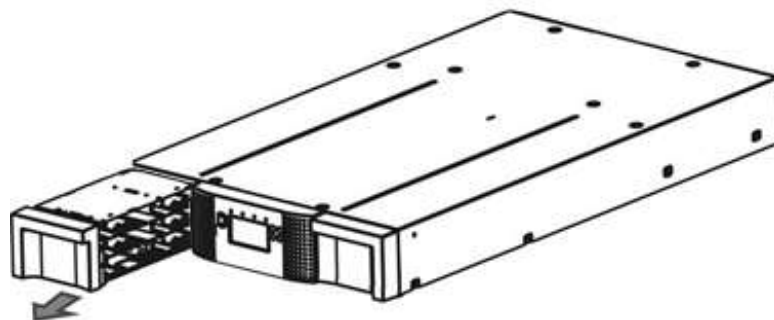

Figure 62 Front panel (magazine removal)

5. If necessary, repeat the steps 3 and 4 for the other magazine.
6. If you are unable to remove any tape cartridges or to release the magazines by any of the foregoing methods, contact your service person.

4.5 Upgrade the library firmware

It is advisable to keep the library firmware updated to the latest version.

To update the library firmware, navigate with the RMU or OCP to the appropriate screen:

RMU screen: > Service > Firmware > Upgrade Library Firmware > Upload

OCP screen: > Main Menu > Service > Service Library > Library FW Upgrade by USB

The library firmware must be loaded on a USB stick. Insert the USB stick into the port on the rear panel of the library. The firmware file name will be displayed and can be selected for updating. After updating the library firmware, the library system restarts automatically.

4.6 General diagnostic

4.6.1 System test

The System Test is a general test to verify the usability and reliability of the library. Its duration depends on the test cycles defined.

To run the system test, navigate with the RMU or OCP to the appropriate screen:

RMU screen: > Service > General Diagnostic > System Test

OCP screen: > Main Menu > Service > Service Library > Run Tests > System Test

4.6.2 Slot-to-Slot test

The Slot-to-Slot test shuffles the tapes between the slots to exercise the media changer. At the end of the test the tapes are not returned to their original slots.

To run the Slot-to-Slot test, navigate with the RMU or OCP to the appropriate screen:

RMU screen: > Service > General Diagnostic > Slot to Slot

OCP screen: > Main Menu > Service > Service Library > Run Tests > Slot to Slot Test

4.6.3 Library verify test



NOTE

- The library will remove any tape from the tape drive(s) and go offline when running this test. Verify that any applications using the library have completed before starting the test.
-

The Library verify test is a diagnostic routine called Library Health Check (LHC). It includes:

- Functional testing of all library and drive hardware with the exception of external interfaces.
- Verification of a newly installed machine.
- Verification of repair actions.

To run Library verify test, navigate with OCP to the appropriate screen:

OCP screen: > Main Menu > Service > Service Library > Library Verify

Operations during the Library Health Check (LHC):

1. The test requires user interaction and can only be run from the OCP. The administrator password is required.
2. The library performs a self-test, verifying that it can communicate with the tape drives.
3. The library returns any tapes from the tape drives to their home slots. If the home slot for a tape is unknown, the library will move the tape to the mailslot and prompt the user to remove it.
4. The library then prompts the user to enter the number of cycles to run the test. The maximum is 10 cycles.
5. The library opens the mailslot and prompts the user to insert a scratch tape.
6. The user inserts a scratch tape into the mailslot. If the mailslot is disabled or the user closes the mailslot without inserting a tape into it, the library will perform a shortened version of the test, skipping step 7.
7. The library loads the scratch tape into the first tape drive, then unloads it and returns it to the mailslot. If the user selected to test both the tape drives (if present), the library will load the scratch tape into each tape drive before returning it to the mailslot.
8. The next test expects to find a tape in each of the top row corner slots of the two magazines. The library moves each tape to the tape drive load point and then returns it to its slot. If none of the top-row corner slot positions contains a tape, the test stops and the library displays an error message.
9. If additional cycles remain to be run, the test will return to step 7 if there is a tape in the mailslot or step 8 if not.
10. At the conclusion of the test, the library pops open the mailslot and waits for the user to remove the scratch tape.
11. The library displays the test completion status, including any recoveries or errors that may have occurred.

4.7 Error codes

4.7.1 Error messaging

The internal error messaging between the different modules and tasks contain the following information:

- Error code
- Sub error code
- Affected source element
- Affected target element
- Additional information depending on context and error code

4.7.2 Error Message format

The error message format is a fixed 4-byte length with the following content:

- Error type
- Error code
- Sub error code
- Internal code (active command code)

4.7.3 OCP error reporting

In case of an error or a warning, a popup message appears on the OCP. The information is shown in 3 different message displays, as shown in the following example:

1. General <Error> display Select the <Hint> button to show the <Hint> display.	2. <Hint> display Select the <Detail> button to show the <Detail> display	3. Detail display
		

Figure 63 OCP Error display

4.7.4 RMU error reporting

In case of an error or a warning, the following popup message appears on the RMU. All information will be available in one message box, as shown in the following example:

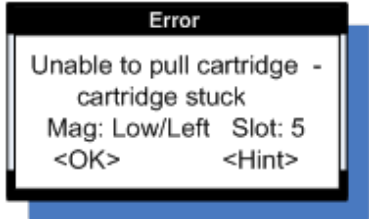
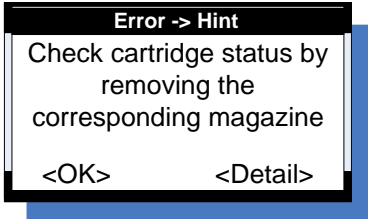
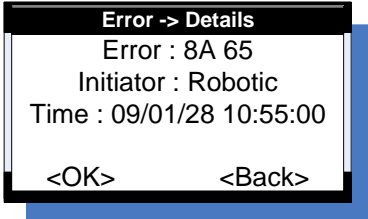
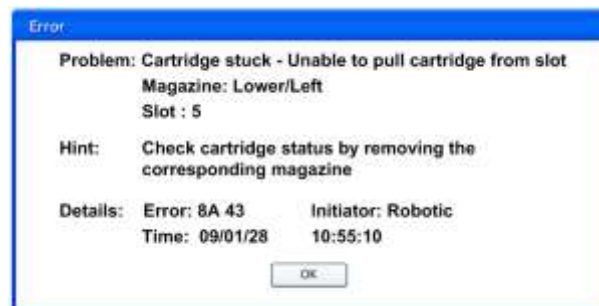

Figure 64 RMU Error display

4.7.5 Main error codes

Error Code	Description	User Action	Critical Component Status
80	Barcode Reader Error, cannot initialize BCR	Retry operation; after several occurrences contact technical support	Media changer probably defective. Flexi cable to BCR not properly connected. Flexi cable to BCR damaged. Barcode engine defect.
81	Barcode Reader Error, no response from BCR	Retry operation; after several occurrences contact technical support	Media changer probably defective. Flexi cable to BCR not properly connected. Flexi cable to BCR damaged. Barcode engine defect.
82	EEPROM Error, no response from EEPROM (located on media changer controller)	Retry operation; after several occurrences contact technical support	Media changer probably defective. Media changer controller not working (hardware problem, EEPROM defect).
83	Media changer controller generic problem	Reset the unit and retry operation. After several occurrences contact technical support	Media changer probably defective. Media changer hardware not working (cables, distribution boards, media changer controller).
84	Setting of gripper motor parameters failed	Reset the unit and retry operation. After several occurrences contact technical support	Media changer probably defective. Elevator distribution board defect. Cabling incorrect.
85	Setting of slider motor parameters failed	Reset the unit and retry operation. After several occurrences contact technical support	Media changer probably defective. Elevator distribution board defect. Cabling incorrect.
86	Setting of elevator motor parameters failed	Reset the unit and retry operation. After several occurrences contact technical support	Media changer probably defective. Elevator distribution board defect. Cabling incorrect.
87	Setting of rotation motor parameters failed	Reset the unit and retry operation. After several occurrences contact technical support	Media changer probably defective. Media changer controller defect.
88	Setting of sled motor parameters failed	Reset the unit and retry operation. After several occurrences contact technical support	Media changer probably defective. Media changer controller defect.

Error Code	Description	User Action	Critical Component Status
89	Gripper blocked	Run 'Library Verify Test', after several occurrences contact technical support	Media changer probably defective. Gripper motor not connected or defect. Gripper motor voltage to low. Media changer controller or distribution boards defect. Check gripper mechanism according stiffness in movement.
8A	Slider blocked	Run 'Library Verify Test', after several occurrences contact technical support	Media changer probably defective. Slider Motor not connected or defect. Slider motor voltage to low. Media changer controller or distribution boards defect. Check slider mechanism according stiffness in movement.
8B	Elevator blocked	Run 'Library Verify Test', after several occurrences contact technical support	Media changer probably defective. Elevator motor not connected or defect. Elevator motor voltage to low. Media changer controller or distribution boards defect. Check elevator mechanism according stiffness in movement
8C	Rotation blocked	Run 'Library Verify Test', after several occurrences contact technical support	Media changer probably defective. Rotation motor not connected or defect. Rotation motor voltage to low. Rotation home sensor defect. Rotation sensor connecting cable damaged. Media changer controller or distribution boards defect.
8D	Sled blocked	Run 'Library Verify Test', after several occurrences contact technical support	Media changer probably defective. Sled motor not connected or defect. Sled motor voltage to low. Sled home sensor defect. Sled sensor connecting cable damaged. Media changer controller or distribution boards defect. Check sled mechanism (guide rail, ducktail) according stiffness in movement.
8E	Cannot find gripper block within the expected range	Run 'Library Verify Test', after several occurrences contact technical support	Media changer probably defective. Elevator distribution board defect. Cabling incorrect. Check gripper gears.

Error Code	Description	User Action	Critical Component Status
8F	Cannot find slider block within the expected range	Run 'Library Verify Test', after several occurrences contact technical support	Media changer probably defective. Elevator distribution board defect. Cabling incorrect. Check slider gears.
90	Cannot find elevator block within the expected range	Run 'Library Verify Test', after several occurrences contact technical support	Media changer probably defective. Elevator distribution board defect. Cabling incorrect. Check elevator gears.
91	Cannot find rotation block within the expected range	Run 'Library Verify Test', after several occurrences contact technical support	Media changer probably defective. Cabling incorrect. Check rotation gears.
92	Cannot find sled block within the expected range	Run 'Library Verify Test', after several occurrences contact technical support	Media changer probably defective. Cabling incorrect. Check sled gears.
93	Gripper outside range, Gripper has reached a position beyond the expected range	Run 'Library Verify Test', after several occurrences contact technical support	Media changer probably defective. Elevator distribution board defect. Cabling incorrect. Check gripper gears.
94	Slider outside range, Slider has reached a position beyond the expected range	Run 'Library Verify Test', after several occurrences contact technical support	Media changer probably defective. Elevator distribution board defect. Cabling incorrect. Check slider gears.
95	Elevator outside range, Elevator has reached a position beyond the expected range	Run 'Library Verify Test', after several occurrences contact technical support	Media changer probably defective. Elevator distribution board defect. Cabling incorrect. Check elevator gears.
96	Rotation outside range, Rotation has reached a position beyond the expected range	Run 'Library Verify Test', after several occurrences contact technical support	Media changer probably defective. Cabling incorrect. Check rotation gears.
97	Sled outside range, Sled has reached a position beyond the expected range	Run 'Library Verify Test', after several occurrences contact technical support	Media changer probably defective. Cabling incorrect. Check sled gears.
98	Cartridge present sensor not found	Run 'Library Verify Test', after several occurrences contact technical support	Media changer probably defective. Media changer controller defect. Cartridge present sensor defect (mechanics, electronics). Cabling incorrect.

Error Code	Description	User Action	Critical Component Status
99	Sled home sensor not found	Run 'Library Verify Test', after several occurrences contact technical support	Media changer probably defective. Media changer controller defect. Slider home sensor defect (mechanics, electronics). Cabling incorrect.
9A	Rotation home sensor not found	Run 'Library Verify Test', after several occurrences contact technical support	Media changer probably defective. Media changer controller defect. Rotation home sensor defect (mechanics, electronics). Cabling incorrect.
9B	Sled position sensor (prism sensor) not found,	Run 'Library Verify Test', after several occurrences contact technical support	Media changer probably defective. Media changer controller defect. Sled home sensor defect (mechanics, electronics). Cabling incorrect.
9C	Gripper range out of specification	Run 'Library Verify Test', after several occurrences contact technical support	Media changer probably defective. Gripper motor not connected or defect. Media changer controller or distribution boards defect. Check gripper mechanism according stiffness in movement
9D	Slider range out of specification	Run 'Library Verify Test', after several occurrences contact technical support	Media changer probably defective. Slider motor not connected or defect. Media changer controller or distribution boards defect. Check slider mechanism according stiffness in movement.
9E	Elevator range out of specification	Run 'Library Verify Test', after several occurrences contact technical support	Media changer probably defective. Elevator motor not connected or defect. Media changer controller or distribution boards defect. Check elevator mechanism according stiffness in movement.
9F	Rotation range out of specification	Run 'Library Verify Test', after several occurrences contact technical support	Media changer probably defective. Rotation motor not connected or defect. Media changer controller or distribution boards defect. Check rotation mechanism according stiffness in movement.

Error Code	Description	User Action	Critical Component Status
A0	Sled range out of specification	Run 'Library Verify Test', after several occurrences contact technical support	Media changer probably defective. Sled motor not connected or defect. Media changer controller or distribution boards defect. Check sled mechanism according stiffness in movement.
A1	Open MailSlot (Import/Export Element) failed	Retry operation, after several occurrences contact technical support	MailSlot release mechanism defect
A3	Sled motor #2 blocked (Note: only relevant for 8U)	Run 'Library Verify Test', after several occurrences contact technical support	Media changer probably defective. Sled motor #2 not connected or defect. Sled motor #2 voltage too low. Sled home sensor #2 defect. Sled sensor #2 connecting cable damaged. Media changer controller or distribution boards defect. Check top sled mechanism (gears, sheet guide locking) according stiffness in movement.
A4	Cannot find sled #2 block within the expected range (Note: only relevant for 8U)	Run 'Library Verify Test', after several occurrences contact technical support	Media changer probably defective. Cabling incorrect. Check top sled mechanism (gears, sheet guide locking).
A5	Sled home sensor #2 not found (Note: only relevant for 8U)	Run 'Library Verify Test', after several occurrences contact technical support	Media changer probably defective. Media changer controller defect. Sled home sensor #2 defect (mechanics, electronics). Cabling incorrect.
A6	Elevator sensor not found (Note: only relevant for 8U)	Run 'Wellness Test', after several occurrences contact technical support	Media changer probably defective. Media changer controller or distribution boards defect. Elevator sensor defect (mechanics, electronics). Cabling incorrect. Elevator motor not connected or defect. Elevator motor voltage to low. Check elevator mechanism according stiffness in movement.

Error Code	Description	User Action	Critical Component Status
B0	Media changer controller response timeout. A command did not complete in the required amount of time.	Reset the unit and retry operation. After several occurrences contact technical support	Media changer probably defective. No communication from library controller to media changer controller. Media changer hardware not working (cables, distribution boards, media changer controller). Download media changer firmware fails.
B1	NAK received from media changer controller	Reset the unit and retry operation. After several occurrences contact technical support	Media changer probably defective. Communication from library controller to media changer controller disturbed. Media changer hardware not working (cables, distribution boards, media changer controller). Download media changer firmware fails.
B2	Media changer controller communication failed	Reset the unit and retry operation. After several occurrences contact technical support	Media changer probably defective. No communication from library controller to media changer controller. Media changer hardware not working (cables, distribution boards, media changer controller). Download media changer firmware fails.
B3	Media changer controller urgent stop due to a released magazine	Check if magazine are completely inserted and retry operation. After several occurrences contact technical support	Magazines released Magazine present sensor defect.
B4	Cartridge did not transport completely Gripper could not pick cartridge and CP sensor not present After pushing the cart CP sensor still present		CP sensor defective. Cartridge sticks in slot/drive
B5	Media changer controller doesn't respond on command	Reset the unit and retry operation. After several occurrences contact technical support	Media changer probably defective. No communication from library controller to media changer controller. Media changer hardware not working (cables, distribution boards, media changer controller). Download media changer firmware fails.

Error Code	Description	User Action	Critical Component Status
C0	Network initialization failed	Check network cable and network configuration. If the error recurs, contact technical support	Library controller probably defective. Probably a hardware problem, check library controller
C1	Telnet Interface initialization failed	Check network cable and network configuration. If the error recurs, contact technical support	Library controller probably defective. Probably a hardware problem, check library controller
C2	Web server initialization failed	Check network cable and network configuration. If the error recurs, contact technical support	Library controller probably defective. Probably a hardware problem, check library controller
C6	Ping command did not reach target	Check network cable and network configuration. If the error recurs, contact technical support	Library controller probably defective. Probably a hardware problem, check library controller
C7	Cannot Upgrade from USB	Retry of Firmware upgrade, if not successful contact technical support	Library controller probably defective. Probably a hardware problem, check library controller
C8	Cannot Upgrade from FTP	Retry of Firmware upgrade, if not successful contact technical support	Library controller probably defective. Probably a hardware problem, check library controller
C9	Cannot Upgrade Media changer from Flash	Retry of Firmware upgrade, if not successful contact technical support	Library controller probably defective. Probably a hardware problem, check library controller
D0	ROM error. ROM checksum incorrect	Retry of Firmware upgrade, if not successful contact technical support	Library controller probably defective. Probably a hardware problem, check library controller
D1	RAM error. Power on Self Test (POST) has failed,	Retry operation; after several occurrences contact technical support	Library controller probably defective. RAM defect, check library controller
D2	NVRAM error. R/W operation to NVRAM has failed	Retry operation; after several occurrences contact technical support	Library controller probably defective. Probably a hardware problem, check library controller
D3	CTC Error. Timer unit has failed during POST.	Retry operation; after several occurrences contact technical support	Library controller probably defective. Probably a hardware problem, check library controller

Error Code	Description	User Action	Critical Component Status
D4	UART Error. Frame overrun or Parity Error on serial Interface.	Retry operation; after several occurrences contact technical support	Check library and media changer controller
D5	Display Error Communication to display failed	Retry operation; after several occurrences contact technical support	Check library controller and OCP
D6	Memory Error, Stack and heap overflow.	Retry operation; after several occurrences contact technical support	Library controller probably defective.
D7	Fatal system error	Retry operation; after several occurrences contact technical support	Library controller probably defective. Probably a hardware problem, check library controller
D8	Data base error	Retry operation; after several occurrences contact technical support	Library controller probably defective. Probably a hardware problem, check library controller
D9	No SCSI IC detected	Retry operation; after several occurrences contact technical support	SCSI controller probably defective. Check SCSI controller and library controller
DA	In Library Verify Test the barcode reader has read different barcode data for the same cartridge label	Check barcode label on scratch cartridge and run Library Verify Test again. If the error recurs, contact technical support	
DB	Warning event! See section below		
DC	I ² C Bus Failure	Retry operation; after several occurrences contact technical support	Failure in I ² C bus communication. Check library controller and connections to OCP and backplane. Check OCP. Check backplane. Check drive sleds.
DD	Warning event! See section below		
DE	Warning event! See section below		
DF	Warning event! See section below		
E0	Incompatible magazine detected	Check type of lowest left magazine	Magazine type not supported.

Error Code	Description	User Action	Critical Component Status
E2	Unsupported hardware (Library Extender) detected – Library firmware upgrade required	Library Extender was installed without upgrading the library firmware. Upgrade library code to revision which supports this feature	
EB	Power supply health check failed due to a power supply failure. Please contact service.	Contact technical support	Power supply probably defective.
F0	Drive Over temperature Condition The sub code indicates which drive is affected Example: Sub code 01: drive #1	Check ambient temperature conditions and check all fans, after several occurrences contact technical support	Drive probably defective.
F1	Drive Communication Error, Library controller has lost communication to drive The sub code indicates which drive is affected Example: Sub code 01: drive #1	Retry operation; if not successful contact technical support	Communication cable between drive and drive sled controller defective. Drive sled controller defective. Check cabling drive sled controller-backplane Check cabling backplane library controller Drive defect / check drive
F2	Drive sled not present The sub code indicates which drive sled is affected Example: Sub code 01: drive sled #1	Retry operation; if not successful contact technical support	Drive probably defective. Check if drive sled is completely inserted Drive sled controller defect. Drive defective.
F3	Drive Hardware Error The sub code indicates which drive is affected Example: Sub code 01: drive #1	Cycle Power; after several occurrences contact technical support	Drive probably defective.

Error Code	Description	User Action	Critical Component Status
F4	Drive Load Timeout Drive has run in a timeout while loading a tape The sub code indicates which drive is affected	Retry operation; if not successful contact technical support	Drive probably defective. Drive leader bent. Drive initialize repeatedly. Drive defect (no function).
F5	Drive Unload Timeout Drive has run in a timeout while unloading a tape The sub code indicates which drive is affected	Retry operation; if not successful contact technical support	Drive probably defective. Drive leader bent. Drive initialize repeatedly. Drive defect (no function).
F8	Invalid drive command	Retry operation; if not successful contact technical support	Drive probably defective.
F9	Invalid drive parameter	Retry operation; if not successful contact technical support	Drive probably defective.
FA	SDCI microcode error	Retry operation; if not successful contact technical support	Drive probably defective.
FB	Drive logged out	Retry operation; if not successful contact technical support	Drive probably defective.
FC	Internal SCSI command failed with check condition	Retry operation; if not successful contact technical support	Drive probably defective.
FD	Internal SCSI command timeout	Retry operation; if not successful contact technical support	Drive probably defective.

Table 7 Error codes

4.7.6 Sub error codes related to the media changer

01	Mechanical initialization failure
02	Connection to slave media changer failed
03	Error motor initialization
04	Error during gripper close
05	Error slider home positioning
06	Error elevator home movement
07	Error during sled movement to rotation position
08	Error during rotation initialization, get range failed
09	Error elevator initialization
0A	Error during rotation to far position
0B	Error first sled initialization, move to sensor failed
0C	Error during sled movement to rotation position
0D	Error during rotation to drive position
0E	Error slider initialization, get range failed
0F	Error during slider forward movement
10	Error gripper initialization, get range failed
11	Error during slider home movement
12	Error during rotation to FAR position
13	Error sled initialization, move to sensor failed
14	Error during sled move – check shipping lock
20	Error Inventory scan
21	Error during gripper close
22	Error slider home movement
23	Error during move gripper to scan pos
24	Error reading barcode label
25	Error during move sled to scan position
26	Error during move elevator to scan position
27	Error during sled preposition movement
29	Error during closing gripper
2A	Error slider preposition movement
2B	Error during opening gripper
2C	Error during sled movement up to sensor
2D	Error slider preposition backwards movement
30	Error slot preposition
31	Error during sled movement in <FLMoveRotation> function
32	Command sending to media changer failed
33	Error during elevator movement in <FLMoveRotation> function
34	Error during rotation in <FLMoveRotation> function
35	Error during elevator movement in <FLMoveSled> function
36	Error during sled movement in <FLMoveSled> function
37	Error during sled positioning to sensor in <FLMoveSled> function
38	Error during sled positioning to mailslot in <FLMoveSled> function
39	Error during sled positioning without sensor
3A	Error during elevator movement without sensor
3B	Error slot position sensor not found
40	Movement to/from slot failed

41	Error during first slider movement
42	Error during first gripper movement
43	Error during second slider movement
44	Error during second gripper movement, get range failed
45	Error during third slider movement, move home failed
46	Error during set hold current to avoid torsion
50	Preposition to drive failed
51	Elevator movement to home sensor failed
52	Sled movement to home sensor failed
53	Error during sled movement to drive position
54	Error during rotation to drive position
55	Error during elevator movement in drive position
56	Error during sled movement to rotation position
57	Error during rotation to end position
60	Move from/to drive failed
61	Error during first slider movement
62	Error during first gripper movement
63	Error during second slider movement
64	Error during second gripper movement, get range failed
65	Error during third slider movement, move home failed
70	Release magazine failed
71	Error during sled movement to rotation position
72	Error during rotation to unlock position
73	Error during move sled to block
80	Opening mailslot failed
81	Error during movement to mailslot open position
82	Error during moving back - sensor was found
90	Movement to home position failed
91	Elevator movement to home position failed
92	Error during sled movement to rotation position
93	Error during rotation to home or far position
94	Sled movement to home sensor position failed
95	Sled movement to transport position failed
99	Error during rotation movement to rotation min position
A0	Movement to mailslot failed
A1	Sled movement to sensor failed
A2	Sled movement to rotation position failed
A3	Elevator movement to home position failed
A4	Error during rotation to far position
A5	Sled movement to mailslot position failed
A6	Error during elevator movement to position
A7	Error during mailslot detection
B0	EEPROM on media changer controller not accessible or error during r/w operation
B1	Save/restore configuration settings: not enough internal memory available for creating the file and restoring the file respectively
B2	Save/restore configuration settings: restore buffer corrupted, checksum calculation failed
B3	Save/restore configuration settings: data base field corrupted
B4	Save/restore configuration settings: invalid personality
B5	Save/restore configuration settings: invalid file

4.7.7 Sub error codes related to the library

- 81 Tape drive wake up failed
- 88 Error accessing slot status
- 90 Media changer load not reached tape present sensor
- 91 No activity after <Load> command
- 92 Timeout while loading tape
- 93 No activity after <Load> command
- 94 Timeout drive unload
- 95 Tape drive terminated unsuccessfully
- 96 Tape not ejected at robot unload
- 97 Slot not free at robot unload
- 98 Tape not seated in <Load> phase 1

5 Servicing

This section provides instructions for servicing the Q24/Q48 Library.

5.1 Tools that may be needed

- Flat-blade screwdrivers (large and small)
- #2 and #3 Phillips screwdriver
- Ground strap

5.2 Electrostatic discharge



CAUTION

Static sensitive - Risk of damage to devices

- A discharge of static electricity can damage static-sensitive devices or micro circuitry.
- Proper packaging and grounding techniques are necessary precautions to prevent damage.

To prevent damaging the system, be aware of the precautions you need to follow when setting up the system or handling parts. A discharge of static electricity from a finger or other conductor may damage system boards or other static-sensitive devices. This type of damage may reduce the life expectancy of the device.

To prevent electrostatic damage, observe the following precautions:

- Transport products in static-safe containers such as conductive tubes, bags, or boxes.
- Keep electrostatic-sensitive parts in their containers until they arrive at static-free workstations.
- Cover the library with approved static-dissipating material.
- Provide a wrist strap connected to the work surface and properly grounded tools and equipment.
- Place parts on a grounded surface before removing them from their containers.
- Keep the work area free of non-conducting materials, such as ordinary plastic assembly aids and foam packing.
- Make sure you are always properly grounded when touching a static-sensitive component or assembly.
- Avoid touching pins, leads, or circuitry.
- Use conductive field service tools
- If you do not have any of the suggested equipment for proper grounding, have an authorized reseller install the part.

5.3 Removing a tape drive



NOTE

- A tape drive is hot pluggable. It is not mandatory to power down the library to replace a drive.

Adhere strictly to the following steps to remove a tape drive:

1. Unload the tape cartridge from the tape drive (if present) using:
OCP, see **Section 3.1.7**
RMU, see **Section 3.2.8.1**
2. Remove all affected tape drive cables on the rear panel.
3. Loosen the blue thumbscrews located on the rear of the tape drive with your fingers.
4. Slightly pull out and push down the tab containing the product ID label so it does not interfere with the tape drive as shown below.
5. Pull the tape drive by the handle straight out of the library.

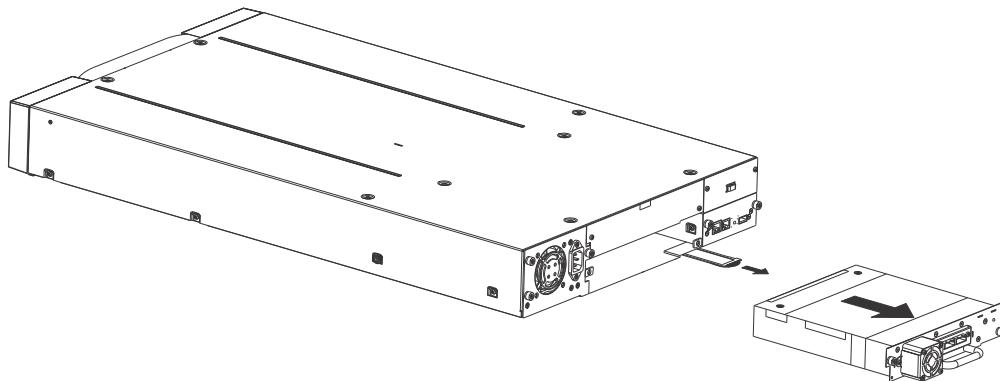

Figure 65 Remove a tape drive

6. To store or ship the removed tape drive, repackage it in the original or replacement device packaging materials.

5.4 Replacing a tape drive

Use this procedure to replace the tape drive with another tape drive:

1. Remove the tape drive from the library, as described above.
2. To install the new tape drive, see **Section 2.9**

5.5 Removing the library controller

Adhere strictly to the following steps to remove a power supply:

1. Power down the library by pressing the power button on the front panel.
2. Remove the power cord from the rear panel of the library.
3. Remove all cables from the library controller on the rear panel of the library.
4. Loosen the blue thumbscrews located on the library controller with your fingers.
5. Pull the library controller straight out of the library as shown below.

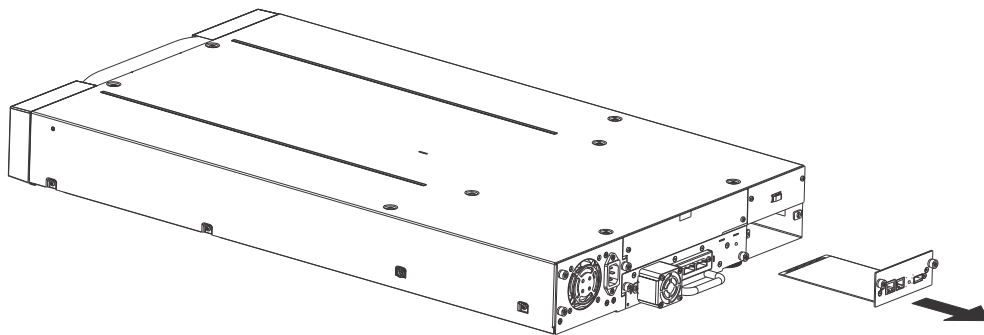

Figure 66 Remove the library controller

6. To store or ship the removed library controller, repackage it in the original or replacement device packaging materials.

5.6 Replacing the library controller

Use this procedure to replace the library controller with another library controller:

1. Remove the library controller from the library, as described above.
2. To install the new library controller, see **Section 2.10**

5.7 Removing the power supply

Adhere strictly to the following steps to remove a power supply:

1. Power down the library by pressing the power button on the front panel.
2. Remove the power cord on the rear panel of the library.
3. Loosen the blue thumbscrews located on the rear of the power supply with your fingers.
4. Pull the power supply straight out of the library as shown below.

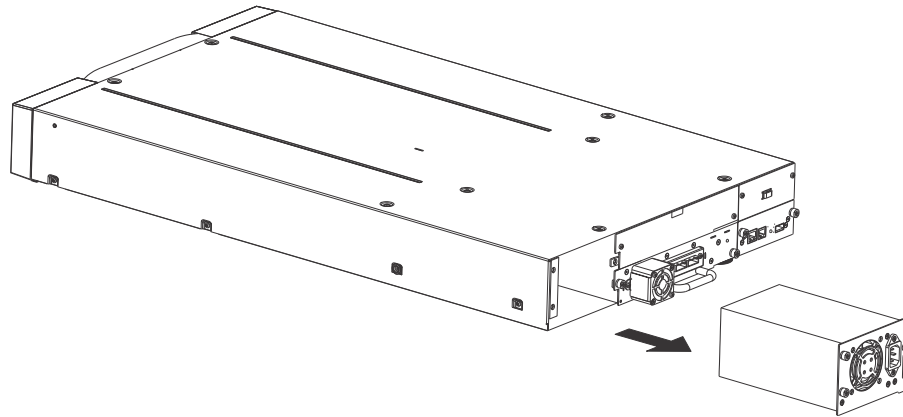

Figure 67 Remove the power supply

5. To store or ship the removed power supply, repackage it in the original or replacement device packaging materials.

5.8 Replacing the power supply

Use this procedure to replace the power supply with another power supply:

1. Remove the power supply from the library, as described above.
2. To install the new power supply, see **Section 2.11**

5.9 Servicing a magazine

To remove a magazine, adhere to the following steps:

1. Unlock the appropriate magazine, using:
 - OCP, see **Section 3.1.7**
 - RMU, see **Section 3.2.8.3**
2. Emergency release, if you are not able to unlock the magazine with the OCP or RMU, see **Section 4.4**
3. Pull the released magazine out of the library.
4. Remove all tape cartridges from the magazine.
5. To store or ship the removed magazine, repackage it in the replacement device packaging materials.
6. Insert an appropriate magazine into the empty magazine slot of the library.

- Slide the magazine completely into the library. The magazine will lock into place once it is correctly installed.

5.10 Removing the base chassis



WARNING

Weight of Q24/Q48 Tape Library - Risk of personal injury

Before lifting a library:

- Observe local health and safety requirements and guidelines for manual material handling.
- Remove all tape cartridges to reduce the weight.
- Obtain adequate assistance to lift and stabilize the library during installation or removal.

5.10.1 Preparing to remove the base chassis

Adhere strictly to the following steps:

- If the OCP or RMU is working:
 - Write down the system, drive, and network configuration settings. You will need these settings to re-configure the library after replacing the base chassis.
 - Remove all tape cartridges to reduce the weight, see **Section 4.3**
 - Remove the magazines from the library, with:
 - OCP, see **Section 3.1.7**
 - RMU, see **Section 3.2.8.3**
- If the OCP or RMU does not work, remove the magazines manually. See **Section 4.4**.
- Power down the library by pressing the power button on the front panel.
- Remove the cables from the rear panel of the library.
- Remove the power supply; see **Section 5.7**
- Remove the tape drive(s); see **Section 5.3**
- Remove the library controller; see **Section 5.5**

5.10.2 Removing the base chassis from the rack

To remove the base chassis from the rack, adhere strictly to the following steps:

- Using a 3# Phillips screwdriver placed through the small holes in the mounting bracket to loosen the M5 screw(s) on each side of the library.
- Remove the library from the rack rails, and then remove the mounting brackets of the library.
- If available:
 - Remove the shipping lock and the yellow label from the rear panel.
 - Insert the shipping lock into the slot on top of the library.
 - Stick the yellow label over the shipping lock to secure it in place.

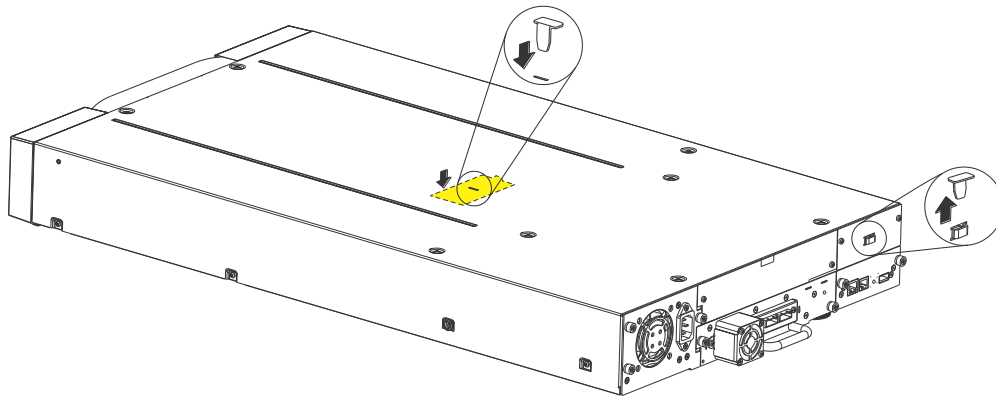

Figure 68 Re-installing Shipping Lock

4. To store or ship the removed base chassis, repackage it in its original packaging materials, see **Section 6**.

5.11 Replacing the base chassis

1. Remove the base chassis from the rack, as described above.
2. To install the new base chassis and its components, see **Section 2**.

6 Packaging the unit for transportation



WARNING

Weight of Q24/Q48 Tape Library - Risk of personal injury

Before lifting a library:

- Observe local health and safety requirements and guidelines for manual material handling.
- Obtain adequate assistance to lift and stabilize the library during packaging.



NOTE

- Before transporting the library, the shipping lock and the yellow label must be replaced into the slot on the top cover of the library from its storage slot on the rear panel.

Before packaging the library:

1. Pull out the tab with the product ID label (1)
2. Note the part and serial number (2)

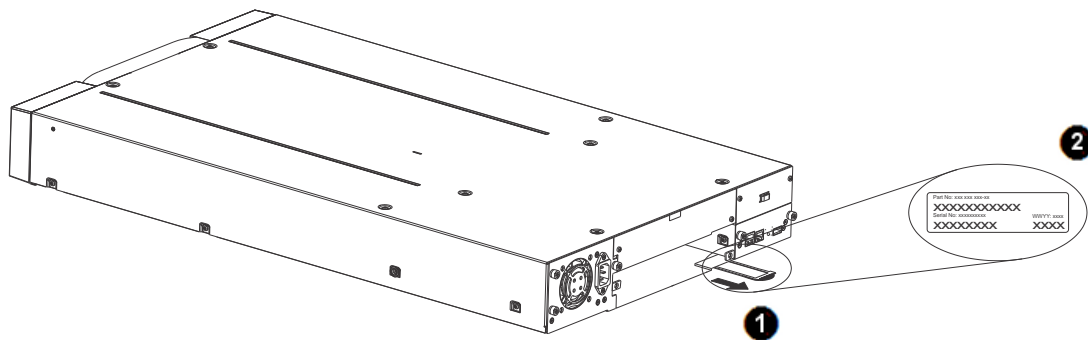

Figure 69 Product ID label

3. Package the appropriate library as shown in **Figure 70** or **Figure 71**.
4. If returning the unit to Qualstar for repair, please call the Technical Support department to request an RMA number (See: **Contacting Qualstar**)

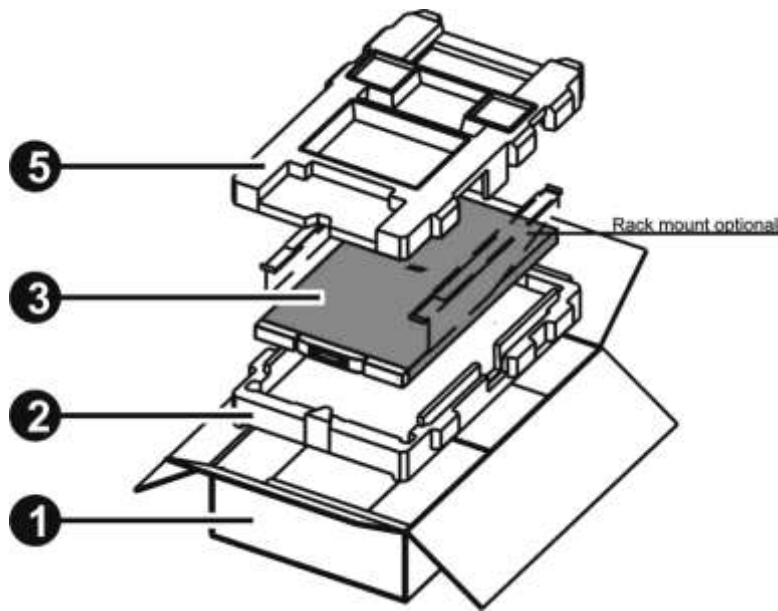

Figure 70 Packaging the Q24 library

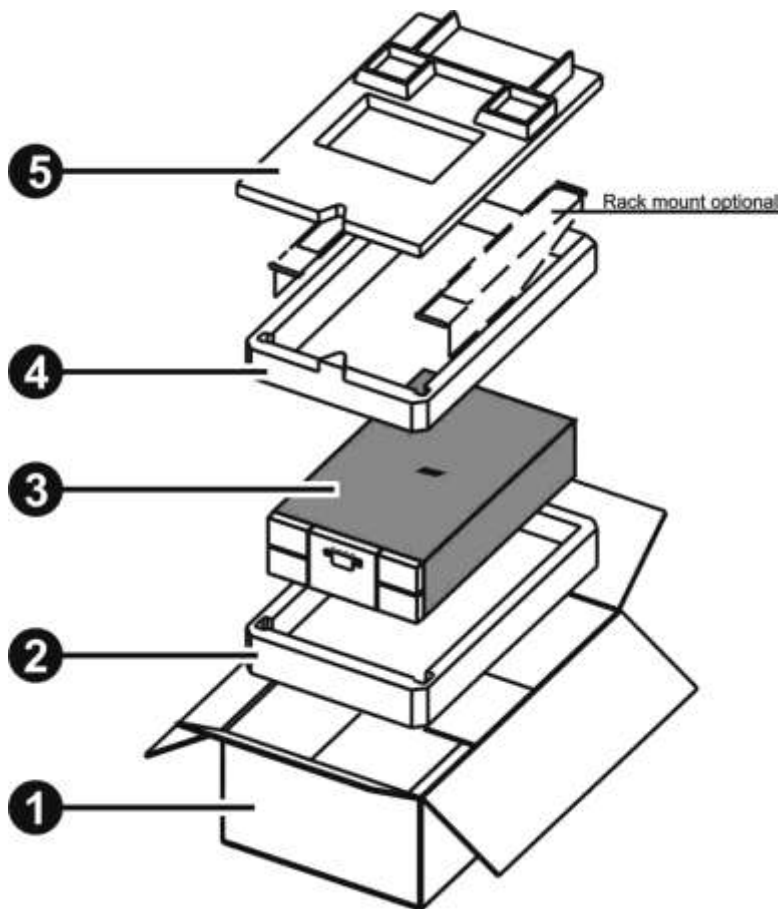

Figure 71 Packaging the Q48 library

Step	Description
1	Packaging box
2	Bottom shell
3	Library
4	Middle shell (Q48 only)
5	Top shell

Table 8 Packaging the library

7 Technical specifications

7.1 Hardware specifications

Library Model	Q24	Q48
Height	Product alone: 3.5" / 8.9 cm Packaged: 9.8" / 24.8 cm	Product alone: 6.93" / 17.6 cm Packaged: 13.0" / 33.0 cm
Width	Product alone: 17.6" / 44.8 cm Packaged: 23.5" / 59.8 cm	Product alone: 17.6" / 44.8 cm Packaged: 23.1" / 58.5cm
Depth	Product alone: 29.2" / 74.0 cm Packaged: 39.1" / 99.3 cm	Product alone: 29.2" / 74.0 cm Packaged: 39.0" / 99.0 cm
Weight without media	2 HH drive unit: 34 lb / 15.6 kg	2 HH drive unit: 53.6 lb / 24.3kg 4 HH drive unit: 57.6lb / 26.1kg
Weight with media	2 HH drive unit: 46 lb / 21.1 kg	2 HH drive unit: 74.1 lb / 33.6 kg 4 HH drive unit: 77.9 lb / 35.3 kg

Table 9 Hardware specifications

7.2 Operating environment

Operating	Temperature	10°C to 35°C
	Max. temperature rise	10 °C / hour
	Humidity	15 % RH to 85 % R.H. (non-condensing)
	Maximum wet bulb	26 °C
	Max. humidity rise	10% / hour
	Altitude operating	0 to 13,000 ft (4200 m) at 25 °C ambient
Non-operating Storage and Shipping	Temperature	-40 °C to +60 °C
	Max. temperature rise	20°C / hour
	Humidity	5 % RH to 90% RH (non-condensing)
	Altitude	-7 m to 10,668 m (-22 to 35,000 feet)

Table 10 Operating environment

7.3 Maximum storage capacity and data transfer rate

Characteristics	Specification
Q24 tape library with LTO8 drive(s)	
Maximum storage capacity (24 data cartridges)	Native: 288 TB Compressed: 720 TB (assuming 2.5:1 compression)
Maximum data transfer rate (single drive)	Native: 300 MB/sec (1.08 TB/hour) Compressed: 750 MB/sec (2.7 TB/hour) (assuming 2.5:1 compression)
Interface (drive dependent)	6 GB/sec (SAS) 8 GB/sec (FC)

Table 11 Q24 Maximum storage capacity and data transfer rate

Characteristics	Specification
Q48 tape library with LTO8 drive(s)	
Maximum storage capacity (48 data cartridges)	Native: 576 TB Compressed: 1.44 PB (assuming 2.5:1 compression)
Maximum data transfer rate (single drive)	Native: 300 MB/sec (1.08 GB/hour) Compressed: 750 MB/sec (2.7 TB/hour) (assuming 2.5:1 compression)
Interface (drive dependent)	6 GB/sec (SAS) 8 GB/sec (FC)

Table 12 Q48 Maximum storage capacity and data transfer rate

For additional information, see **Section 2.15, Tape cartridges**

8 Agency certifications



NOTE

- To comply with the following regulations and standards, the library must be properly installed in an office or industrial environment with shielded cables and adequate grounding of the input power source.
-

8.1 Recycling and disposal



NOTE

- Disposal of waste equipment by users in private household in the European Union and Norway.
-

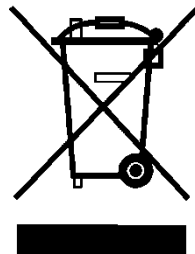

Figure 72 WEEE symbol

This symbol on the product or on its packaging indicates that this product must not be disposed of with your other household waste. Instead, it is your responsibility to dispose of your equipment by handing it over to a designated collection point for the recycling of waste electrical and electronic equipment. The separate collection and recycling of your waste equipment at this time of disposal will help to conserve natural resources and ensure that it is recycled in a manner that protects human health and the environment. For more information about where you can drop off your waste equipment for recycling, please contact your local city office, your household waste disposal service or the shop where you purchased the product.

8.2 Device standards

- ANSI Small Computer System Interface-2 (SCSI-2), X3.131 – 1994
- ANSI SCSI-3 Primary Commands, X3.301 - 1997
- ANSI Information and Technology, SCSI-3 Medium Changer Commands (SMC), NCITS.314:1998
- ANSI SCSI Parallel Interface-2 (SIP-2), X3.302:1998
- IEC 60297 Rack Standards

European Community	CE scheme according to EN/IEC 60950
USA/Canada	FCC, ETL according to UL 60950
Germany	GS

Figure 73 Device standards

8.3 CE mark



The CE mark is a mandatory conformity mark on many products placed on the single market in the European Economic Area (EEA). The CE marking certifies that a product has met EU consumer safety, health or environmental requirements.

8.4 ETL mark



CONFORMS TO
ANSI/UL 60950-01

CERTIFIED TO
CAN/CSA-
C22.2 No.60950-1-03

The ETL mark is alternative to the UL and CSA marks in the USA. This mark is issued by Intertek. This mark shows that your product meets all the appropriate safety and performance specifications for your market of sale (generally identical to the standards set by UL and CSA).

8.5 GS mark



The Geprüfte Sicherheit ("Tested Safety") or GS mark is a voluntary certification mark for technical equipment. It indicates that the equipment meets German and, if available, European safety requirements for such devices.

8.6 FCC (United States)

The computer equipment described in this manual generates and uses radio frequency (RF) energy. If the equipment is not installed and operated in strict accordance with the manufacturer's instructions, interference to radio and television reception might result.



Tested To Comply
With FCC Standards
For Home or Office Use

This equipment complies with Part 15 of the FCC Rules. Operation is subject to the following conditions: (1) This device may not cause harmful interference, and (2) this device must accept any interference received, including interference that may cause undesired operation.

Part 15, Class A, of the FCC Rules, is designed to provide reasonable protection against radio and television interference in a residential installation. Although the equipment has been tested and found to comply with the allowed RF emission limits, as specified in the above-cited Rules, there is no guarantee that interference will not occur in a particular installation. Interference can be determined by turning the equipment off and on while monitoring radio or television reception. The user may be able to eliminate any interference by implementing one or more of the following measures:

- Reorient the affected device and/or its receiving antenna.
- Increase the distance between the affected device and the computer equipment.
- Plug the computer and its peripherals into a different branch circuit from that used by the affected device.
- If necessary, consult an experienced radio/television technician for additional suggestions.

8.7 Canadian verification

This Class A digital apparatus meets all requirements of the Canadian Interference-Causing Equipment Regulations (ICES-003, Class A).

9 Glossary

FC	Fibre channel
FH	Full-height
HBA	Host bus adapter Connects a host system to other network and storage devices
HH	Half-height
LED	Light Emitting Diode
LTO	Linear Tape-Open Magnetic tape data storage technology
LUN	Logical Unit Number Unique number assigned to each device attached on a SCSI bus. For example, disk and tape drives, media changer, etc.
OCP	Operator Control Panel Includes display, buttons and LED's and enables the user to operate the unit from the front
PCB	Printed Circuit Board Example: Library controller
RMU	Remote Management Unit Provides the capability to operate the unit through a web based remote management interface
SAN	Storage area network Architecture to attach remote computer storage devices
SAS	Serial Attached SCSI Computer bus, which moves data to and from computer storage devices such as hard drives and tape drives
SCSI	Small Computer System Interface Communication interface to the host system
USB	Universal Serial Bus

10 Index

Agency certifications	98	Date/time	52
Canadian verification.....	100	Factory defaults	54
CE mark	99	Library identity, dynamic	42
Device standards	99	Login.....	36
ETL mark.....	99	Operations	35
FCC mark	100	Reboot library.....	58
Recycling and disposal.....	98	Status	40
Default settings.....	64	Packaging	93
Electrostatic discharge.....	87	Product overview and features	1
Error codes	74	Front panel	3
General warnings.....	iv	Rear panel	5
Installing	8	Q24 Power supply	6
Cabling.....	18	Q48 Power supply	6
Ethernet cable.....	19	Tape drive	6
FC cable	18	Servicing.....	87
Power cord.....	18	Base chassis	91
SAS cable.....	19	Library controller	89
FC requirements.....	9	Magazine	90
FC topology (Fabric)	9	Power supply	90
Host preparing.....	11	Tape drive.....	88
Host verifying	20	Sub error codes.....	84, 86
Library controller.....	16	Technical specifications	
Location requirements	8	Hardware specifications	96
Magazines	23	Troubleshooting.....	65
Powering up/down.....	20	Backup.....	65
Precautions.....	11	Bad performance.....	66
Product components.....	12	Cleaning cartridge	66
Rack mounting.....	14	Compatibility	65
Removing the shipping lock	13	Device driver.....	65
Serial attached SCSI (SAS).....	8	Diagnostic	71
Tape cartridges.....	20	Library verify test	71
Labeling.....	22	Slot-to-Slot test	71
Type	20	System test.....	71
Using	21	Emergency release	70
Write-protecting	23	Error codes	72, 74
Tape drive.....	15	Error on OCP.....	66
Unpacking the library	12	Firmware	71
USB device.....	19	Installation problems.....	65
Operating.....	25	Media	67
OCP.....	25	Media Attention LED	68
Operating modes	25	Power	67
Philosophy.....	25	Stuck tape cartridges.....	69
Partitioning.....	61	Sub error codes	84, 86
RMU	35	Tape cartridge movement.....	68